



Ver. 202004



**LG Electronics, Home appliance & Air solution company**

56, Digital-ro 10-gil, Geumcheon-gu, Seoul, Republic of Korea (153-801)

[www.lg.com](http://www.lg.com)

[www.lgeaircon.com](http://www.lgeaircon.com)

## LG HVAC SOLUTION

# ABSORPTION CHILLER

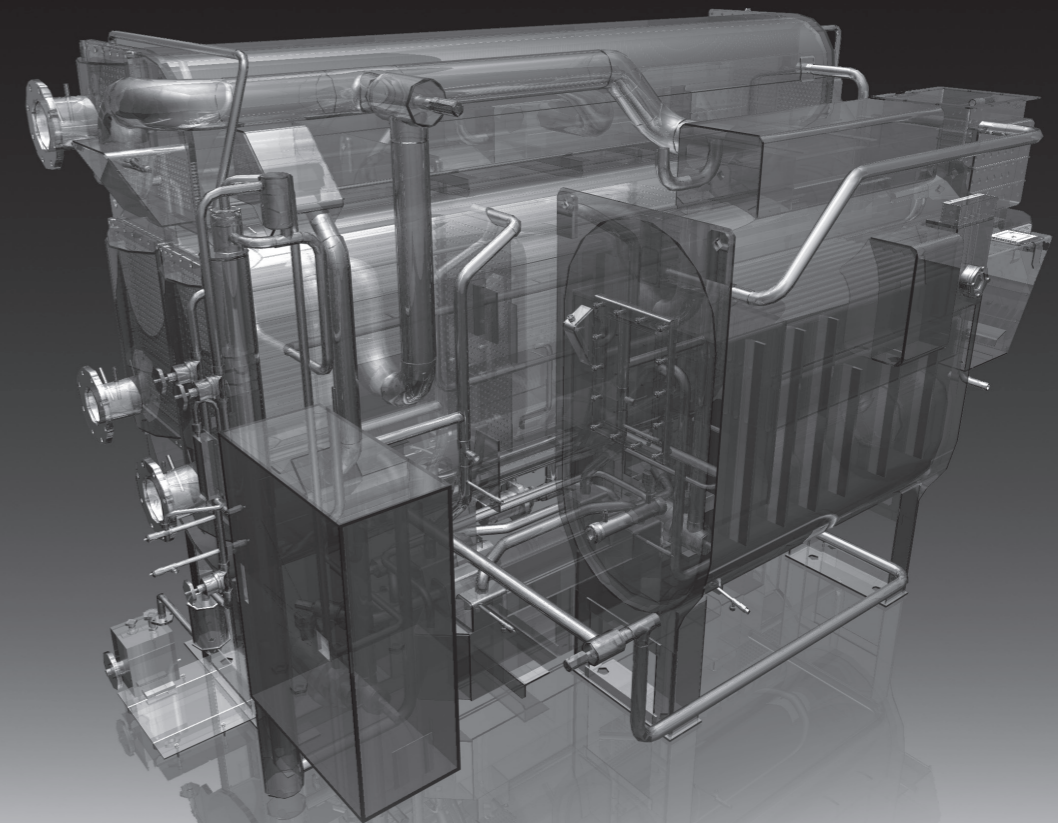
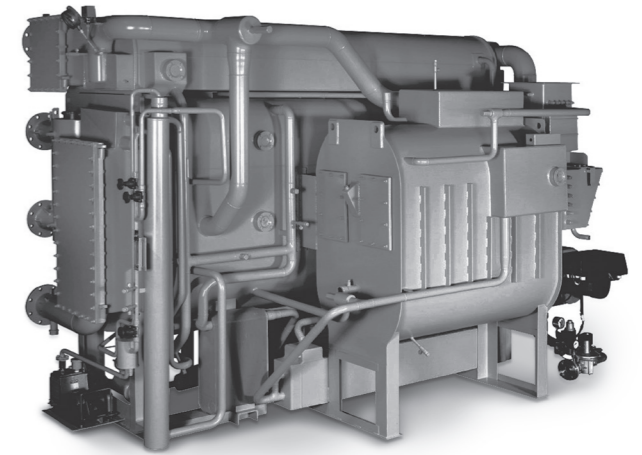

For continual product development, LG reserves the right to change specifications or designs without notice.

© 2020 LG Electronics. Printed in Korea. Apr. 2020

Distributed by

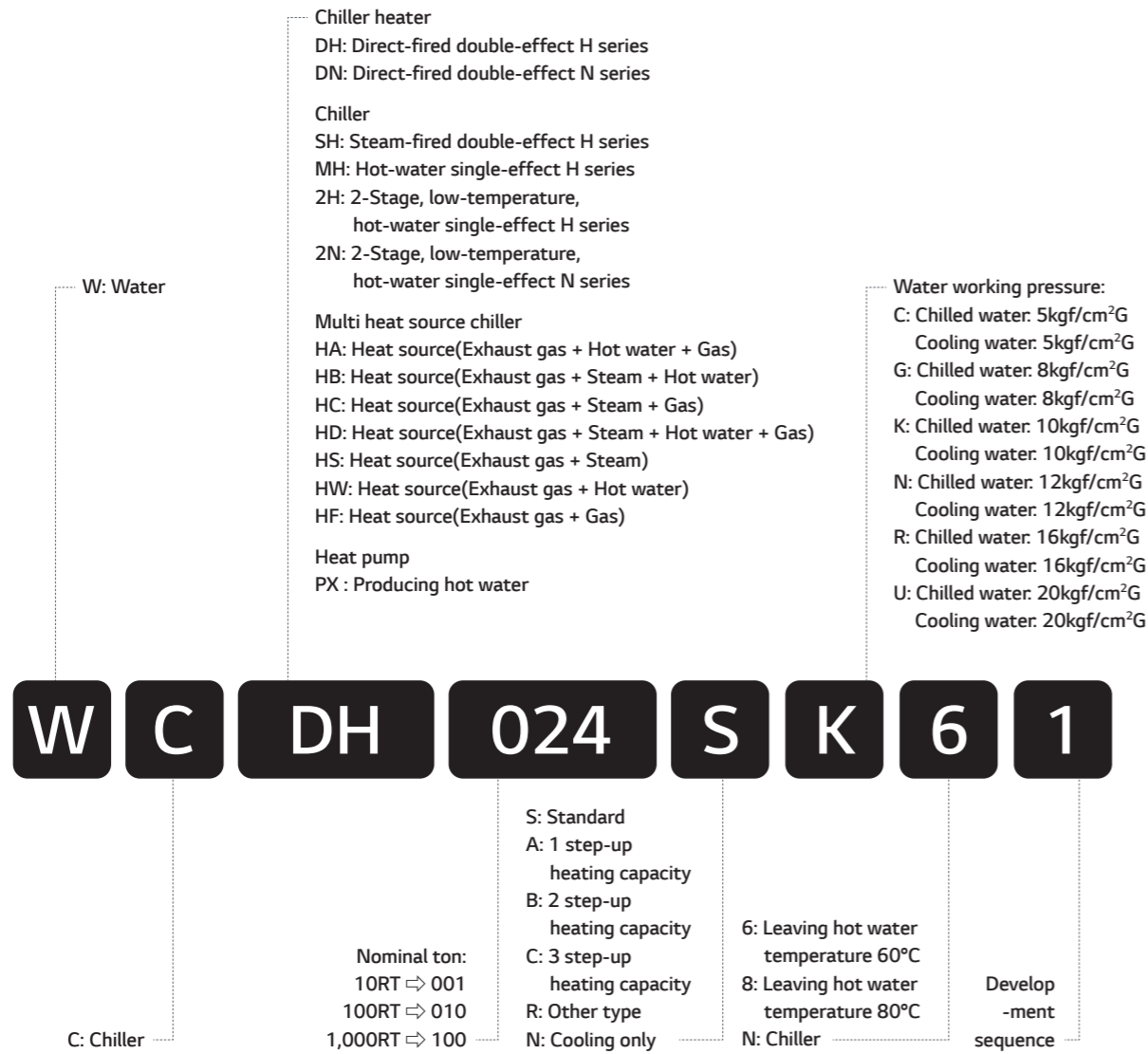

## Contents

- 02 Nomenclature
- 03 Line up & Features
- 09 Options check list
- 10 LG Absorption chiller tube material
- 12 Specification & Cycle diagram
- 44 Thermal insulation
- 46 Piping diagram
- 50 Control of cooling water temperature diagram
- 53 Standard of water quality
- 54 Fuel piping
- 55 Multi-Sectional shipment
- 58 Outline & Foundation
- 77 Schematic diagram
- 80 Interface diagram
- 82 Guide specification

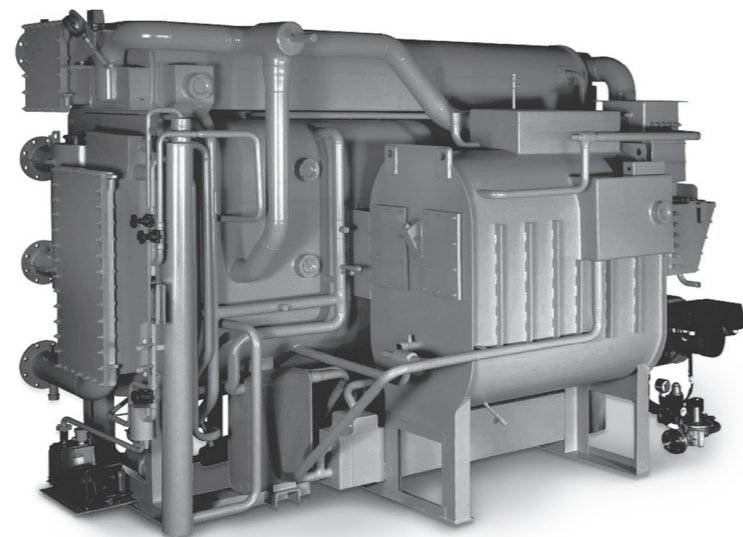

## Line up

Direct fired absorption chiller & heater

Model	0	100	500	1,000	1,500	3,000
WCDH (H Series)		100RT		1,500RT		3,000RT
WCDN (N Series)		100RT		1,500RT		3,000RT

Absorption chiller

Model	0	100	500	1,000	1,500	2,000	3,000	4,000
WCSH Steam fired		100RT		1,500RT		4,000RT		
WCMH Hot water driven		80RT		1,350RT		2,000RT		
WC2H Hot water driven		80RT		1,350RT		2,000RT		
WC2N Hot water driven		80RT		1,350RT		2,000RT		

Hybrid absorption chiller

Model	0	100	500	1,000	1,500	2,000	3,000	4,000
WCHA		100RT					3,000RT	

Heat pump

Model	0	300	1,000	5,000	10,000	20,000	30,000
WCPX Heat pump		349kW					30,218kW

\* Available on request.

**Absorption chiller application**

	Energy	Available	Model Selection			(Example) Application
			Efficiency	Model	Remark	
Chiller	Gas or Oil	LNG LPG Bio-Gas Exhaust gas Oil	COP 1.51	WCDH	World Class High Efficiency	Commercial area Multipurpose building Thermoelectric power plant
			COP 1.41	WCDN	Enhanced Efficiency of the part load(Part load : 75~25%)	
	Steam	Steam pressure 4-8kg/cm <sup>2</sup>	COP 1.51 Consumption(3.5 kg/hRT)	WCSH	World Class High Efficiency Steam Pressure : 4~8kg/cm <sup>2</sup>	Commercial area Multipurpose building Petroleum and Chemical Factory
			COP 0.81	WCMH	World Class High Efficiency Standard outlet Temp. : 72°C	
	Hot Water	Inlet Temperature Standard 95°C	COP 0.73	WC2H	Low Temperature outlet Standard outlet Temp. : 55°C	Solar system District energy system Cogeneration
			COP 0.65	WC2N	Low Temperature outlet Standard outlet Temp. : 55°C	
			COP 1.2	WCHA	Hybrid Absorption Chiller Using more than 2 kinds of heat source	
	Multiple Energy	Exhaust gas + Hot water + (LNG)				
Heat pump	Waste heating Source	Gas Steam Hot water	COP 1.65~1.80	WCPX	World Class High Efficiency Hot water Temp. : 55~90°C	Combined Heat and Power Incinerator system

With over 50% domestic market share, LG Electronics has provided heating, ventilating and air conditioning total solution to industrial and commercial fields over 40 years. Now the company, specialized in absorption, centrifugal & GHP, now wants to share its leading technology with the global friends. The LG Absorption Chillers have always been nation's No.1 energy saving chillers, since the company has considered R&D as frontier mover of all.

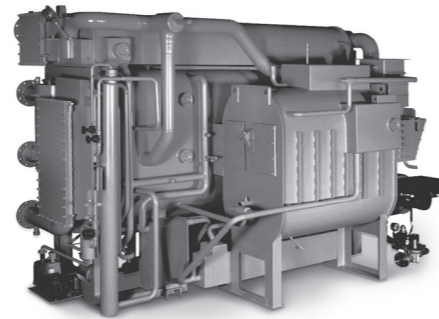

**Features of LG absorption chillers**

- Beneficial where cooling/heating demands are all year around by using diversified energy sources as Gas, Steam and Hot water.
- Reduces operation cost in where electrical costs are high.
- Utilizing environmental safe, non chlorine mixture based refrigerant.
- Reduces green house effect by less using hydrocarbon fuels as well as electricity.

**Reinforced user interface design**

Over 40 years experience with successful delivery of 10,000 units. LG Absorption chiller has been focused on user interface and reliable convenient operations that to considered as a first step of total HVAC solution.

**High efficiency & high energy saving operation**

**Inverter controlled solution pump enabled high part-load efficiency with fast full-loaded operation**

Optimized flow rate of solution is decided upon cooling demand and that to enable highly efficient energy saving operation at all operation range.

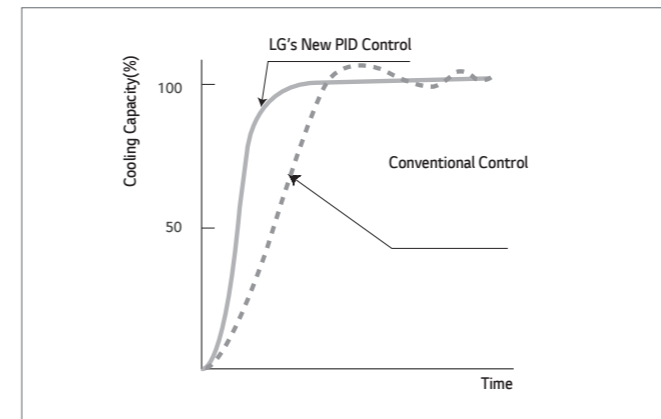

**Reinforced safety operation function**

LG's unique microprocessor keeps monitoring every part of chiller so to prevent any damage could happen at abnormal operation. The machine can stop automatically by reinforced safety function when the chiller operation reached at abnormal state.

**Optimized dilution operation shortened stoppage time**

LG's newly designed microprocessor decides when to equalize concentration of solution in every part of chiller by self diagnostic calculations. Also this led to saving dilution operation as well as energy saving at auxiliary equipments, such as water pumps by reducing idle time from 15 min to 5 min.

**High reliability & practical design**

**High performance of purging system**

Newly designed injector typed, purging either at upper shell and lower shell, a new LG purging system, enabled less purging time and better purging performance.

**Marine hatch type water box**

No need to cut or disassemble for tube cleaning or maintenance purposes, marine hatch typed water box allows an operator to clean tubes in less time.

**Series flow**

- Easy control of absorbent circulation rate by load
- Reduce Facility installation cost by reduce cooling water flow
- Enable absorbent circulation rate control and Pump Soft Start/Stop by inverter pump
- Easy operation
- No damage by local heating

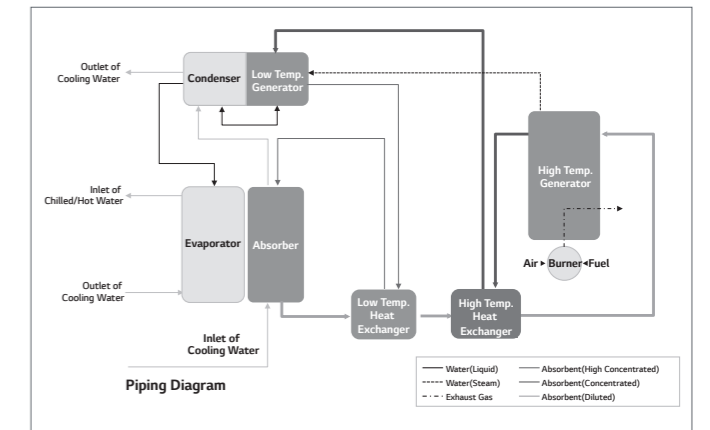

### High performance controller

Delicate Designed with PID Control Logic, a new Micro Processor enables LG Chiller be always at optimum operation state

### A new quick response PID control logic

A quick response, new LG designed PID algorithm enabled high sensitive combustion control rate that to meet minimized reaching time of demand temperature.

It also reduced the fluctuating temperature difference so that to enable constant temperature control logic.

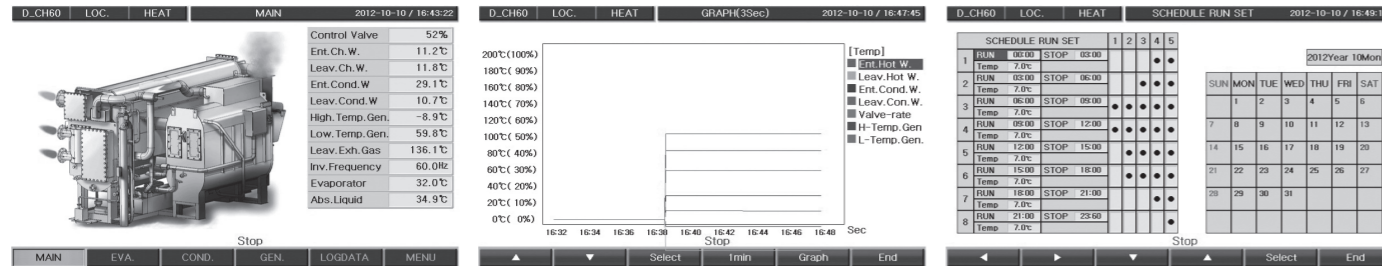
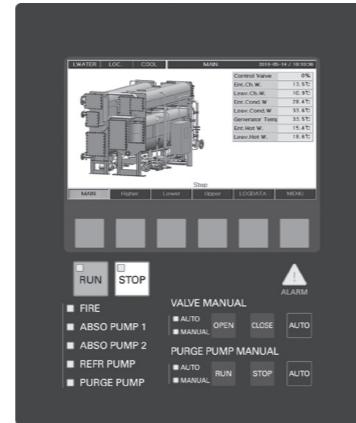

7" Color LCD with high resolution

Real time operation status

Time schedule



Evaporator & absorber

Low temperature generator

High temperature generator

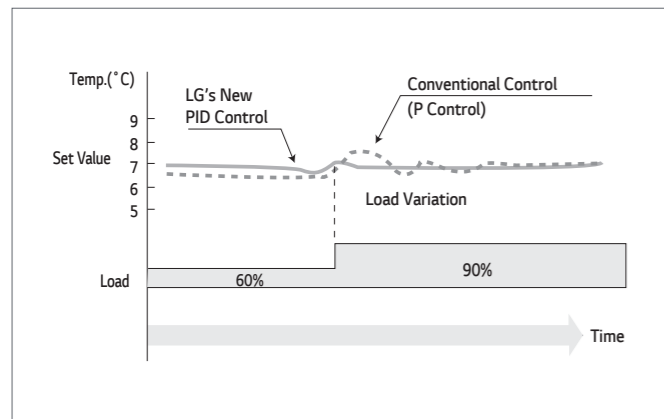

A new Quick Response PID Control Logic

### Self diagnostic safety operation

1. Anti-crystallization safety operation  
solution concentration is monitored at micro processor in

all operational condition and keeps concentration level in optimum state by controlling a combustion rate.

2. Cooling water safety operation  
If entering cooling water is too high(About 19~34°C), Micro processor should be controlled combustion rate for safety.

3. Data storage and maintenance  
Micro processor automatically record 300 data as below;

- Normal operation message
- Abnormal operation message
- Sensing data(Temperature, Pressure and so on.)

This recorded data more accurate operational maintenance is capable.

4. Self diagnostics and Malfunction alarm  
If some disturbing factor predicted within normally operation, Chiller controlled itself before stop.

- Maintenance purpose  
Chamber Cleaning: by monitoring exhaust gas temperature, operators can predict right time of cleaning a combustion channel of HTG.(Option)
- Malfunction alarm feature  
Monitoring all sensors for check that status of sensors. If any abnormal signal occurs, it show malfunction reason on the display.

### Absorbent concentration control

Micro processor calculates absorbent concentration by condenser and low temperature generator for preventing absorbent crystallization.

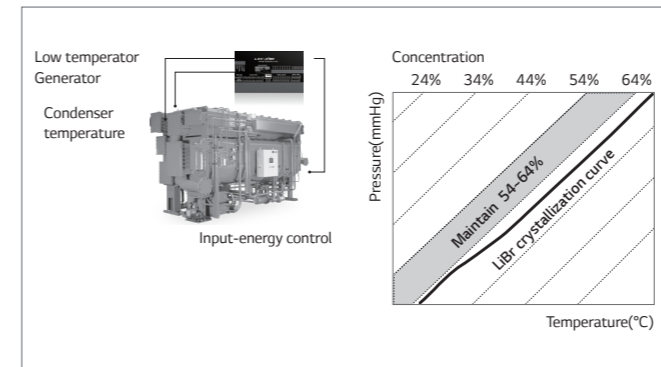

### Auto re-starting after power failure

Micro processor diagnosis itself and then auto re-starting after power failure.

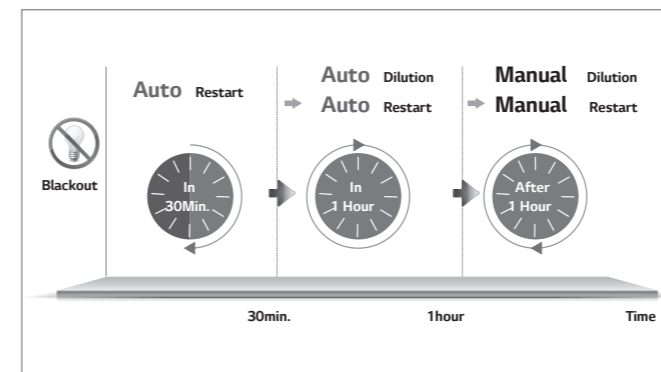

### Maximize System Stability by Self Diagnosis

- Equipment Facility, Self Diagnosis  
Equipment Facility from Controller when Start-up(Chilled water / Cooling water pump, Cooling tower) with Self diagnosis, Customer can prevent from Crystallization and Frozen burst.

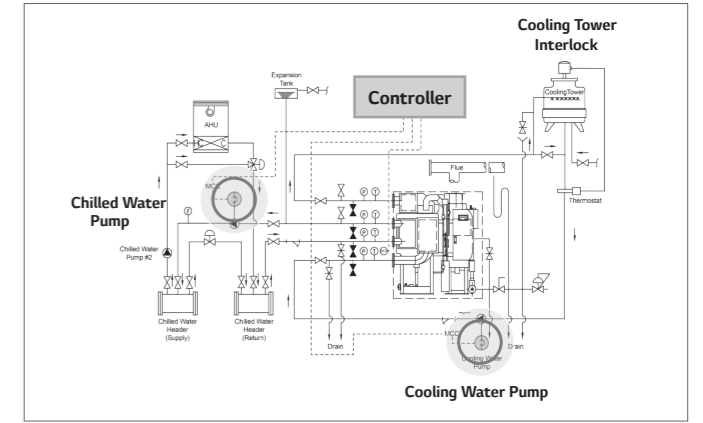

Equip. Facility Diagram

- Safety Device, Self Diagnosis  
Safety device and Sensor status with Self-diagnosis from Controller when Start-up. Customer can prevent from abnormal operation and safety accident.

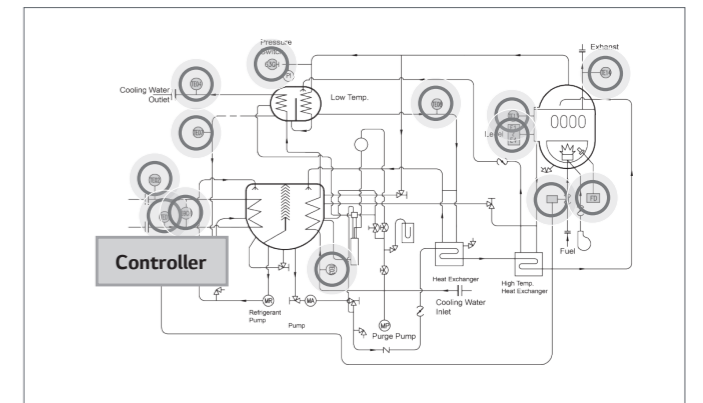

Piping Diagram

### Enhanced user interface designed micro processor

- Real time operation status  
Real time operation status is displayed by text and graph. This real time value is better to understanding about chiller.
- Printer(Optional)  
Stored operation normal/abnormal/alarm history data can be printed out from mounted printer.
- Flow Rate Indication(Optional)  
A flow rate of chilled/cooling water flow rate can be indicated on the display. For this operation an additional transducer should be applied on chilled/cooling water pipe line.
- Interactive system control  
Water pumps and cooling tower fan automatically controlled by micro processor of chiller.
- Schedule Operation  
Chiller automatically operated by setting value of date and time.

Status Display(LED display)	Setting Value
<ul style="list-style-type: none"> <li>Run</li> <li>Stop</li> <li>Cooling</li> <li>Heating</li> </ul>	<ul style="list-style-type: none"> <li>CHW/HW Inlet Temp.</li> <li>CHW/HW Outlet Temp.</li> <li>CW Inlet Temp.</li> <li>CW Outlet Temp.</li> </ul>
Reading Value(LCD display)	Reading Value(LCD display)
<ul style="list-style-type: none"> <li>CHW/HW Inlet Temp.</li> <li>CHW/HW Outlet Temp.</li> <li>CW Inlet Temp.</li> <li>H.gen Temp.</li> <li>L.gen Temp.</li> <li>Condensing Temp.</li> <li>Remote Set Temp.</li> <li>Control V/V Open(%)</li> <li>Libr Concentration</li> <li>Inverter(Hz)</li> <li>PID Value</li> </ul>	<ul style="list-style-type: none"> <li>Combustion Signal</li> <li>Purge Chamber Pressure</li> <li>H. Gen Level Low</li> <li>Run Mode</li> <li>Control V/V Mode</li> <li>Abs Pump #1 Overload</li> <li>Abs Pump #2 Overload</li> <li>CHW/HW Pump Interlock</li> <li>CW Pump Interlock</li> <li>Pressure Switch</li> <li>Abs Pump #1 Status</li> <li>Abs Pump #2 Status</li> <li>Purge Pump Status</li> <li>CHW/HW Inlet Temp.</li> <li>CHW/HW Outlet Temp.</li> <li>CW Inlet Temp.</li> <li>CW Outlet Temp.</li> </ul>
Operation Time(LCD display)	
<ul style="list-style-type: none"> <li>Running Time</li> <li>Combustion Time</li> <li>Ref. Pump Run Time</li> <li>Abs Pump #1 Run Time</li> <li>Abs Pump #2 Run Time</li> </ul>	
No. Of Run/stop(LCD display)	
<ul style="list-style-type: none"> <li>Running Time</li> <li>Combustion Time</li> <li>Ref. Pump Run Time</li> <li>Abs Pump #1 Run Time</li> <li>Abs Pump #2 Run Time</li> </ul>	

### Group unit system control

#### For intelligent buildings and huge factories

- Communication protocol for Building Automation and Remote monitoring control
  - Easily accessible to user's interface
  - RS485 communication processor installed
  - Modbus is standard, BACnet, Lonwork are available as an option.
  - Operational data acquisition
  - Graphical display of monitoring & control status
  - Data editing and Report generation with MS EXCEL
  - Real-time graphical display of trend data
  - Various graphic display for analog data
  - Password protected
- Optimized Operation
  - Integrated System Management
    - Integrated control of Chillers and Peripheral Equipment which are connected to LG controller
  - Preventative Maintenance
    - Log data management
      - Daily report generation of operation data, abnormal data and etc.
  - Operational Cost Saving
    - Cost saving through centralized monitoring
  - Auxiliary Function
    - Control of peripheral equipment, load control

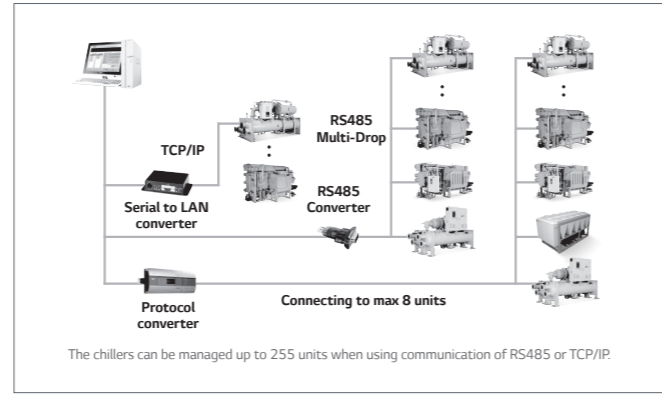

Detailed diagrams of BMS

### AC Smart premium Display

- 10.2-inch color LCD touch screen with high resolution (1,024 x 600)
- Operation scheduling function
- Real time trend display
- Web Access(Additional accessory)
- Running data acquisition
- Easy-to-read display of operational data
- Certified EMI/EMS
- Communication supported: Modbus, RS485(Standard)
- Language: English/Chinese/Korean

### Absorption chiller standard summary

Items	Standard	Option
Main Power	<input type="checkbox"/> 380V	<input type="checkbox"/> 220V <input type="checkbox"/> 400V <input type="checkbox"/> 415V <input type="checkbox"/> 440V
	<input type="checkbox"/> 60Hz	<input type="checkbox"/> 50Hz
	<input type="checkbox"/> Modbus	<input type="checkbox"/> BACnet <input type="checkbox"/> TCP/IP(Ethernet) <input type="checkbox"/> etc( )
	<input type="checkbox"/> IP4X	<input type="checkbox"/> IP54
Control Panel	<input type="checkbox"/> Open Wiring	<input type="checkbox"/> Duct & Flexible
Factory Wiring	<input type="checkbox"/> 150 psig(10kg/cm <sup>2</sup> )	<input type="checkbox"/> 300 psig(20kg/cm <sup>2</sup> ) <input type="checkbox"/> etc( )
	<input type="checkbox"/> Drawing	
Chilled Water	<input type="checkbox"/> ANSI-Flange	<input type="checkbox"/> ANSI-Victaulic(AGS) <input type="checkbox"/> ANSI-Victaulic(OGS)
	<input type="checkbox"/> Inlet+outlet	
Cooling Water	<input type="checkbox"/> 150 psig(10kg/cm <sup>2</sup> )	<input type="checkbox"/> 300 psig(20kg/cm <sup>2</sup> ) <input type="checkbox"/> etc( )
	<input type="checkbox"/> Drawing	
	<input type="checkbox"/> ANSI-Flange	<input type="checkbox"/> ANSI-Victaulic(AGS) <input type="checkbox"/> ANSI-Victaulic(OGS)
	<input type="checkbox"/> N/A	<input type="checkbox"/> DP Switch
Purging	<input type="checkbox"/> Inlet only	<input type="checkbox"/> Inlet+Outlet
	<input type="checkbox"/> N/A	<input type="checkbox"/> Yes
Shipping	<input type="checkbox"/> N/A	<input type="checkbox"/> Yes
	<input type="checkbox"/> Combination	<input type="checkbox"/> Separate
Insulation	<input type="checkbox"/> Yes	<input type="checkbox"/> No
	<input type="checkbox"/> N/A	<input type="checkbox"/> Factory Charge <input type="checkbox"/> Exemption <input type="checkbox"/> etc( )
Insulation Color	<input type="checkbox"/> N/A	<input type="checkbox"/> Black <input type="checkbox"/> etc(Munsell NO. )
	<input type="checkbox"/> N/A	<input type="checkbox"/> Shrink Film <input type="checkbox"/> Wooden Packing
Vibration Isolator	<input type="checkbox"/> N/A	<input type="checkbox"/> Neoprene PAD
	<input type="checkbox"/> N/A	<input type="checkbox"/> Dry test report only
Factory Performance Test	<input type="checkbox"/> N/A	<input type="checkbox"/> Customer Witness test with 100% load only
	<input type="checkbox"/> N/A	<input type="checkbox"/> Customer Witness test with 100% load & ( )% load(s)
Warranty	<input type="checkbox"/> 1yr	<input type="checkbox"/> etc( )
	<input type="checkbox"/> N/A	<input type="checkbox"/> etc( )
Labor Warranty	<input type="checkbox"/> N/A	<input type="checkbox"/> Anchor bolts <input type="checkbox"/> Solution Filter <input type="checkbox"/> Purging - Solenoid v/v
	<input type="checkbox"/> N/A	<input type="checkbox"/> Companion Flange <input type="checkbox"/> Purging - Auto Purge System
Others(Optional)	<input type="checkbox"/> N/A	<input type="checkbox"/> Horizontality Plate <input type="checkbox"/> Isolation Valve(Pump inlet/outlet)
	<input type="checkbox"/> N/A	<input type="checkbox"/> Standard Spare Parts <input type="checkbox"/> PF Condenser
Standard Specification	1) Factory Wiring : Open Wiring 2) Color : Dawn Gray - Control Panel : Warm Gray 3) Controller : MICOM 4) Flow proof type : DP Switch(Evaporator)	

## Absorption chiller material summary

Part	Available	Material		
		H-type(WCDH/WCSH Series)	N-type(WCDN Series)	MH-type(WCMH Series)
Lower Unit	Evaporator Tube		Copper	
	Absorber Tube		Copper	
Upper Unit	Condenser Tube		Copper	
	Generator Tube		Copper	
High Temp. Unit	High Generator Tube		Carbon Steel(WCSH: Stainless Steel)	
Upper, Lower High Temp. Unit	Shell		Rolled Steel	
	Tube Sheet		Rolled Steel	
	Eliminator		Stainless Steel	
	WaterBox		Rolled Steel	
	Pipings		Carbon Steel	

Part	Available	Material	
		2H/2N-type(WC2H / WC2N Series)	
Lower Unit	Evaporator Tube		Copper
	Absorber Tube		Copper
Upper Unit	2nd Generator Tube		Copper
	Aux. Absorber		Copper
High Temp. Unit	1st Generator Tube		Copper
	Aux. Generator Tube		Copper
	Condenser Tube		Copper
Upper, Lower High Temp. Unit	Shell		Rolled Steel
	Tube Sheet		Rolled Steel
	Eliminator		Stainless Steel
	WaterBox		Rolled Steel
	Pipings		Carbon Steel

## Absorption chiller material summary

Part	Available	Material	
		HH-type(WCHA Series)	
Lower Unit	Evaporator Tube		Copper
	Absorber Tube		Copper
Upper Unit	Condenser Tube		Copper
	Low Generator Tube		Copper
	Hot W. Generator Tube		Copper
High Shell Unit	Exh. Generator Tube		Carbon Steel
	High Generator Tube		Carbon Steel
Upper, Lower High Temp. Unit	Shell		Rolled Steel
	Tube Sheet		Rolled Steel
	Eliminator		Stainless Steel
	WaterBox		Rolled Steel
	Pipings		Carbon Steel

### WCDH Series(Chilled Water 12°C - 7°C COP 1.51)

Model name		WCDH010	WCDH012	WCDH015	WCDH018	WCDH021	WCDH024	
Cooling Capacity	usRT	100	120	150	180	210	240	
	kW	352	422	527	633	738	844	
Heating Capacity	kcal/h	253,000	253,000	303,600	379,500	455,400	531,300	
	kW	294	294	353	441	530	618	
Chilled Water Data	Temperature	°C 12 → 7						
	Water Flow Rate	m <sup>3</sup> /h	60.5	72.6	90.7	108.9	127	145.2
	Pressure Drop	mAq	7.7	7.7	9.9	10.0	9.3	9.7
	Connection Size	A(mm)	100	100	100	100	125	125
		B(inch)	4	4	4	4	5	5
Hot Water Data	Temperature	°C 56.2 → 60.0						
	Water Flow Rate	m <sup>3</sup> /h	60.5	72.6	90.7	108.9	127	145.2
	Pressure Drop	mAq	7.7	7.7	9.9	10.0	9.3	9.7
	Connection Size	A(mm)	100	100	100	100	125	125
		B(inch)	4	4	4	4	5	5
Cooling Water Data	Temperature	°C 32 → 37						
	Water Flow Rate	m <sup>3</sup> /h	100	120	150	180	210	240
	Pressure Drop	mAq	5.2	4.9	8.4	8.9	7.2	7.6
	Connection Size	A(mm)	125	125	125	125	150	150
B(inch)		5	5	5	5	6	6	
Fuel(GAS)	Nozzle Size	A(mm)	40(at 4,000mmAq)					
		B(inch)	1 1/2(at 4,000mmAq)					
	Cooling	Nm <sup>3</sup> /h	21.4	25.7	32.1	38.5	44.9	51.3
Heating	Nm <sup>3</sup> /h	27.7	27.7	33.2	41.5	49.8	58.1	
Electrical Data	Source	V	3ø 220/380/440V 50/60Hz					
	Total Current	A	14.3	14.3	14.3	17.7	17.7	19.1
	Thickness Wire	mm <sup>2</sup>	4	4	4	4	4	4
	Power	kVA	9.7	9.7	9.7	12.0	12.0	12.9
	Absorbent Pump No.1	kW	1.5	1.5	1.5	2.4	2.4	2.4
		A	5.43	5.43	5.43	6.4	6.4	6.4
	Absorbent Pump No.2	kW	0.4	0.4	0.4	1.2	1.2	1.2
		A	1.6	1.6	1.6	4.1	4.1	4.1
	Refrigerant Pump	kW	0.2	0.2	0.2	0.2	0.2	0.2
		A	1.1	1.1	1.1	1.1	1.1	1.1
	Purge Pump	kW	0.4	0.4	0.4	0.4	0.4	0.4
		A	1.0	1.0	1.0	1.0	1.0	1.0
	BuDHer Blower(Gas)	kW	1.5	1.5	1.5	1.5	1.5	2.2
		A	4.6	4.6	4.6	4.6	4.6	6.0
Dimension	Length	mm	2,895	2,895	3,745	3,745	3,795	3,795
	Width	mm	2,100	2,100	2,090	2,095	2,150	2,170
	Height	mm	2,070	2,070	2,070	2,070	2,415	2,415
Rigging	Operating	ton	5.4	5.6	6.4	7.0	8.4	8.8
	Total Shipping	ton	5.0	5.0	6.1	6.7	7.8	8.4
	Max Shipping	ton	4.2	4.3	5.0	5.4	6.4	6.8
Flue Connection Size	mm	340 x 320	340 x 320	340 x 320	340 x 320	340 x 320	380 x 430	
Clearance For Tube Removal	mm	2,400	2,400	3,400	3,400	3,400	3,400	

Note:  
 1. 1usRT = 3,024kcal/h, 1kW = 860kcal/h  
 2. Standard inlet water & outlet water Temperature of Chilled water : 12→7°C  
 3. Standard inlet water & outlet water Temperature of Hot water : 56.2→60°C  
 4. Standard inlet water & outlet water Temperature of Cooling water : 32→37°C  
 5. Standard Fouling factor of Chilled & Cooling water : 0.086m<sup>2</sup>K/kW(0.0001m<sup>2</sup>.h.°C)  
 6. Standard Tube and Water Side Pressure(Chiller & Cooling Water Circuit): 10kg/cm<sup>2</sup>G(981kPa)  
 7. Standard gas pressure : 4,000mmAq  
 8. Recommend Gas pressure : Low Pressure 200mmAq, Mid. Pressure 900mmAq, High Pressure 4000mmAq

9. Standard low calorific power : 9,360 kcal/Nm<sup>3</sup>  
 10. Currents & Electricity Consumptions are based on 3ø 380V 60Hz  
 11. Power supply wire size is based on the due of metal conduit and 40°C of ambient temperature.  
 12. Total Shipping Weight include weight of the burner & liquid.  
 13. The specifications are subject to change without prior notice.  
 14. For other than above this table, contact nearest LG Electronics office.  
 15. Length is the value without the burner attached.

### WCDH Series(Chilled Water 12°C - 7°C COP 1.51)

Model name		WCDH028	WCDH032	WCDH036	WCDH040	WCDH045	WCDH050	
Cooling Capacity	usRT	280	320	360	400	450	500	
	kW	985	1,125	1,266	1,407	1,582	1,758	
Heating Capacity	kcal/h	607,200	708,400	809,600	910,800	1,012,000	1,138,500	
	kW	706	824	941	1,059	1,177	1,324	
Chilled Water Data	Temperature	°C 12 → 7						
	Water Flow Rate	m <sup>3</sup> /h	169.3	193.5	217.7	241.9	272.2	302.4
	Pressure Drop	mAq	6.2	6.5	7.0	7.1	6.3	6.4
	Connection Size	A(mm)	150	150	150	150	200	200
		B(inch)	6	6	6	6	8	8
Hot Water Data	Temperature	°C 56.2 → 60.0						
	Water Flow Rate	m <sup>3</sup> /h	169.3	193.5	217.7	241.9	272.2	302.4
	Pressure Drop	mAq	6.2	6.5	7.0	7.1	6.3	6.4
	Connection Size	A(mm)	150	150	150	150	200	200
		B(inch)	6	6	6	6	8	8
Cooling Water Data	Temperature	°C 32 → 37						
	Water Flow Rate	m <sup>3</sup> /h	280	320	360	400	450	500
	Pressure Drop	mAq	6.5	6.7	7.1	7.4	6.6	6.7
	Connection Size	A(mm)	200	200	200	200	250	250
B(inch)		8	8	8	8	10	10	
Fuel(GAS)	Nozzle Size	A(mm)	40(at 4,000mmAq)			50(at 4,000mmAq)		
		B(inch)	1 1/2(at 4,000mmAq)			2(at 4,000mmAq)		
	Cooling	Nm <sup>3</sup> /h	59.9	68.5	77.0	85.6	96.3	107.0
Heating	Nm <sup>3</sup> /h	66.4	77.5	88.6	99.6	110.7	124.5	
Electrical Data	Source	V	3ø 220/380/440V 50/60Hz					
	Total Current	A	19.1	24.2	31.2	31.2	31.2	33.0
	Thickness Wire	mm <sup>2</sup>	4	4	6	6	6	6
	Power	kVA	12.9	16.2	20.8	20.8	20.8	22.0
	Absorbent Pump No.1	kW	2.4	3.4	3.4	3.4	3.4	3.4
		A	6.4	10.3	10.3	10.3	10.3	10.3
	Absorbent Pump No.2	kW	1.2	1.5	1.5	1.5	1.5	2.0
		A	4.1	5.0	5.0	5.0	5.0	6.8
	Refrigerant Pump	kW	0.2	0.4	0.4	0.4	0.4	0.4
		A	1.1	1.4	1.4	1.4	1.4	1.4
	Purge Pump	kW	0.4	0.4	0.4	0.4	0.4	0.4
		A	1.0	1.0	1.0	1.0	1.0	1.0
	BuDHer Blower(Gas)	kW	2.2	2.2	5.5	5.5	5.5	5.5
		A	6.0	6.0	13.0	13.0	13.0	13.0
Dimension	Length	mm	4,815	4,815	4,890	4,890	4,900	4,900
	Width	mm	2,225	2,225	2,430	2,515	2,785	2,855
	Height	mm	2,415	2,415	2,590	2,590	2,925	2,925
Rigging	Operating	ton	10.4	10.8	13.2	14.0	16.0	17.2
	Total Shipping	ton	9.7	10.3	12.2	13.3	15.2	16.3
	Max Shipping	ton	7.7	8.2	9.7	10.8	12.6	13.3
Flue Connection Size	mm	380 x 430	380 x 430	380 x 430	450 x 430	450 x 430	520 x 550	
Clearance For Tube Removal	mm	4,500	4,500	4,500	4,500	4,500	4,500	

Note:  
 1. 1usRT = 3,024kcal/h, 1kW = 860kcal/h  
 2. Standard inlet water & outlet water Temperature of Chilled water : 12→7°C  
 3. Standard inlet water & outlet water Temperature of Hot water : 56.2→60°C  
 4. Standard inlet water & outlet water Temperature of Cooling water : 32→37°C  
 5. Standard Fouling factor of Chilled & Cooling water : 0.086m<sup>2</sup>K/kW(0.0001m<sup>2</sup>.h.°C)  
 6. Standard Tube and Water Side Pressure(Chiller & Cooling Water Circuit): 10kg/cm<sup>2</sup>G(981kPa)  
 7. Standard gas pressure : 4,000mmAq  
 8. Recommend Gas pressure : Low Pressure 200mmAq, Mid. Pressure 900mmAq, High Pressure 4000mmAq

9. Standard low calorific power : 9,360 kcal/Nm<sup>3</sup>  
 10. Currents & Electricity Consumptions are based on 3ø 380V 60Hz  
 11. Power supply wire size is based on the due of metal conduit and 40°C of ambient temperature.  
 12. Total Shipping Weight include weight of the burner & liquid.  
 13. The specifications are subject to change without prior notice.  
 14. For other than above this table, contact nearest LG Electronics office.  
 15. Length is the value without the burner attached.

### WCDH Series(Chilled Water 12°C - 7°C COP 1.51)

Model name		WCDH056	WCDH063	WCDH070	WCDH080	WCDH090	WCDH100	
Cooling Capacity	usRT	560	630	700	800	900	1,000	
	kW	1,969	2,215	2,461	2,813	3,165	3,516	
Heating Capacity	kcal/h	1,265,000	1,416,800	1,593,900	1,771,000	2,024,000	2,277,000	
	kW	1,471	1,647	1,853	2,059	2,353	2,648	
Chilled Water Data	Temperature	°C 12 → 7						
	Water Flow Rate	m <sup>3</sup> /h	338.7	381	423.4	483.8	544.3	604.8
	Pressure Drop	mAq	6.3	8.7	11.6	10.2	13.9	6.0
	Connection Size	A(mm)	200	200	200	250	250	250
		B(inch)	8	8	8	10	10	10
Hot Water Data	Temperature	°C 56.2 → 60.0						
	Water Flow Rate	m <sup>3</sup> /h	338.7	381	423.4	483.8	544.3	604.8
	Pressure Drop	mAq	6.3	8.7	11.6	10.2	13.9	6.0
	Connection Size	A(mm)	200	200	200	250	250	250
		B(inch)	8	8	8	10	10	10
Cooling Water Data	Temperature	°C 32 → 37						
	Water Flow Rate	m <sup>3</sup> /h	560	630	700	800	900	1,000
	Pressure Drop	mAq	5.7	7.8	10.2	6.1	8.2	10.8
	Connection Size	A(mm)	300	300	300	350	350	350
B(inch)		12	12	12	14	14	14	
Fuel(GAS)	Nozzle Size	A(mm)	50(at 4,000mAq)					
		B(inch)	2(at 4,000mAq)					
	Cooling	Nm <sup>3</sup> /h	119.8	134.8	149.8	171.2	192.6	214.0
Heating	Nm <sup>3</sup> /h	138.4	155.0	174.4	193.7	221.4	249.1	
Electrical Data	Source	V	3ø 220/380/440V 50/60Hz					
	Total Current	A	33.3	41.6	41.6	41.6	52.0	58.9
	Thickness Wire	mm <sup>2</sup>	10	10	10	16	16	16
	Power	kVA	22.4	27.9	27.9	27.9	34.7	39.3
	Absorbent Pump No.1	kW	3.4	6.6	6.6	6.6	7.5	7.5
		A	10.3	16.2	16.2	16.2	25.0	25.0
	Absorbent Pump No.2	kW	2.0	2.0	2.0	2.0	2.2	2.2
		A	6.8	6.8	6.8	6.8	5.8	5.8
	Refrigerant Pump	kW	0.4	0.4	0.4	0.4	1.5	1.5
		A	1.4	1.4	1.4	1.4	4.0	4.0
	Purge Pump	kW	0.4	0.4	0.4	0.4	0.4	0.4
A		1.0	1.0	1.0	1.0	1.0	1.0	
BuDHer Blower(Gas)	kW	5.5	7.5	7.5	7.5	7.5	11.0	
	A	13.0	15.4	15.4	15.4	15.4	22.3	
Dimension	Length	mm	5,310	5,520	6,010	5,635	6,130	6,590
	Width	mm	3,025	3,150	3,150	3,800	3,920	3,920
	Height	mm	3,295	3,295	3,295	3,550	3,600	3,600
Rigging	Operating	ton	21.4	24.0	27.2	32.4	38.2	42.2
	Total Shipping	ton	19.8	22.0	23.5	28.5	33.0	35.1
	Max Shipping	ton	16.3	17.8	19.1	23.3	26.7	28.7
Flue Connection Size	mm	520 x 550	650 x 550	650 x 550	650 x 550	750 x 550	750 x 550	
Clearance For Tube Removal	mm	4,500	5,200	5,700	5,200	5,700	6,200	

- Note:
- 1usRT = 3,024kcal/h, 1kW = 860kcal/h
  - Standard inlet water & outlet water Temperature of Chilled water : 12→7°C
  - Standard inlet water & outlet water Temperature of Hot water : 56.2→60°C
  - Standard inlet water & outlet water Temperature of Cooling water : 32→37°C
  - Standard Fouling factor of Chilled & Cooling water : 0.086m<sup>2</sup>K/kW(0.0001m<sup>2</sup>.h.°C)
  - Standard Tube and Water Side Pressure(Chiller & Cooling Water Circuit): 10kg/cm<sup>2</sup>G(981kPa)
  - Standard gas pressure : 4,000mAq
  - Recommend Gas pressure : Low Pressure 200mAq, Mid. Pressure 900mAq, High Pressure 4000mAq
  - Standard low calorific power : 9,360 kcal/Nm<sup>3</sup>
  - Currents & Electricity Consumptions are based on 3ø 380V 60Hz
  - Power supply wire size is based on the due of metal conduit and 40°C of ambient temperature.
  - Total Shipping Weight include weight of the burner & liquid.
  - The specifications are subject to change without prior notice.
  - For other than above this table, contact nearest LG Electronics office.
  - Length is the value without the burner attached.

### WCDH Series(Chilled Water 12°C - 7°C COP 1.51)

Model name		WCDH110	WCDH120	WCDH130	WCDH140	WCDH150	
Cooling Capacity	usRT	1,100	1,200	1,300	1,400	1,500	
	kW	3,868	4,220	4,571	4,923	5,274	
Heating Capacity	kcal/h	2,530,000	2,783,000	3,036,000	3,289,000	3,542,000	
	kW	2,942	3,236	3,530	3,824	4,119	
Chilled Water Data	Temperature	°C 12 → 7					
	Water Flow Rate	m <sup>3</sup> /h	665.3	725.8	786.2	846.7	907.2
	Pressure Drop	mAq	5.6	7.1	8.9	7.6	9.3
	Connection Size	A(mm)	300	300	300	350	350
		B(inch)	12	12	12	14	14
Hot Water Data	Temperature	°C 56.2 → 60.0					
	Water Flow Rate	m <sup>3</sup> /h	665.3	725.8	786.2	846.7	907.2
	Pressure Drop	mAq	5.6	7.1	8.9	7.6	9.3
	Connection Size	A(mm)	300	300	300	350	350
		B(inch)	12	12	12	14	14
Cooling Water Data	Temperature	°C 32 → 37					
	Water Flow Rate	m <sup>3</sup> /h	1,100	1,200	1,300	1,400	1,500
	Pressure Drop	mAq	8.3	10.6	13.2	10.9	13.3
	Connection Size	A(mm)	400	400	400	400	400
B(inch)		16	16	16	16	16	
Fuel(GAS)	Nozzle Size	A(mm)	65(at 4,000mAq)				
		B(inch)	2 1/2(at 4,000mAq)				
	Cooling	Nm <sup>3</sup> /h	235.4	256.7	278.1	299.5	320.9
Heating	Nm <sup>3</sup> /h	276.8	304.4	332.1	359.8	387.5	
Electrical Data	Source	V	3ø 220/380/440V 50/60Hz				
	Total Current	A	73.1	73.1	73.1	85.8	85.8
	Thickness Wire	mm <sup>2</sup>	35.0	35.0	35.0	35.0	35.0
	Power	kVA	48.6	48.6	48.6	57.0	57.0
	Absorbent Pump No.1	kW	7.5	7.5	7.5	7.5	7.5
		A	25.0	25.0	25.0	25.0	25.0
	Absorbent Pump No.2	kW	5.5	5.5	5.5	5.5	5.5
		A	20.0	20.0	20.0	20.0	20.0
	Refrigerant Pump	kW	1.5	1.5	1.5	1.5	1.5
		A	4.0	4.0	4.0	4.0	4.0
	Purge Pump	kW	0.4	0.4	0.4	0.4	0.4
A		1.0	1.0	1.0	1.0	1.0	
BuDHer Blower(Gas)	kW	11.0	11.0	11.0	15.0	15.0	
	A	22.3	22.3	22.3	35.0	35.0	
Dimension	Length	mm	6,140	6,660	7,160	6,640	7,360
	Width	mm	4,200	4,300	4,300	4,700	4,850
	Height	mm	3,780	3,780	3,780	3,840	3,840
Rigging	Operating	ton	49.9	55.6	61.5	64.2	70.1
	Total Shipping	ton	39.2	43.2	45.9	50.8	54.5
	Max Shipping	ton	31.3	33.8	35.9	39.7	42.5
Flue Connection Size	mm	750 x 550	850 x 550	850 x 550	850 x 550	850 x 550	
Clearance For Tube Removal	mm	5,700	6,200	6,700	6,200	6,700	

- Note:
- 1usRT = 3,024kcal/h, 1kW = 860kcal/h
  - Standard inlet water & outlet water Temperature of Chilled water : 12→7°C
  - Standard inlet water & outlet water Temperature of Hot water : 56.2→60°C
  - Standard inlet water & outlet water Temperature of Cooling water : 32→37°C
  - Standard Fouling factor of Chilled & Cooling water : 0.086m<sup>2</sup>K/kW(0.0001m<sup>2</sup>.h.°C)
  - Standard Tube and Water Side Pressure(Chiller & Cooling Water Circuit): 10kg/cm<sup>2</sup>G(981kPa)
  - Standard gas pressure : 4,000mAq
  - Recommend Gas pressure : Low Pressure 200mAq, Mid. Pressure 900mAq, High Pressure 4000mAq
  - Standard low calorific power : 9,360 kcal/Nm<sup>3</sup>
  - Currents & Electricity Consumptions are based on 3ø 380V 60Hz
  - Power supply wire size is based on the due of metal conduit and 40°C of ambient temperature.
  - Total Shipping Weight include weight of the burner & liquid.
  - The specifications are subject to change without prior notice.
  - For other than above this table, contact nearest LG Electronics office.
  - Length is the value without the burner attached.



### WCDN Series(Chilled Water 12°C - 7°C COP 1.41)

Model name		WCDN010	WCDN012	WCDN015	WCDN018	WCDN021	WCDN024	
Cooling Capacity	usRT	100	120	150	180	210	240	
	kW	352	422	528	633	739	844	
Heating Capacity	kcal/h	265,000	318,000	398,000	477,000	557,000	636,000	
	kW	308	370	463	554	647	739	
Chilled Water Data	Temperature	°C 12 → 7						
	Water Flow Rate	m <sup>3</sup> /h	60.5	72.6	90.7	108.9	127	145.2
	Pressure Drop	mAq	7.0	7.0	9.0	9.1	8.4	8.8
	Connection Size	A(mm)	100	100	100	100	125	125
		B(inch)	4	4	4	4	5	5
Hot Water Data	Temperature	°C 55.6 → 60						
	Water Flow Rate	m <sup>3</sup> /h	60.5	72.6	90.7	108.9	127.0	145.2
	Pressure Drop	mAq	7.0	7.0	9.0	9.1	8.4	8.8
	Connection Size	A(mm)	100	100	100	100	125	125
		B(inch)	4	4	4	4	5	5
Cooling Water Data	Temperature	°C 32 → 37						
	Water Flow Rate	m <sup>3</sup> /h	100	120	150	180	210	240
	Pressure Drop	mAq	4.5	4.5	7.4	7.8	6.1	6.5
	Connection Size	A(mm)	125	125	125	125	150	150
		B(inch)	5	5	5	5	6	6
Fuel(GAS)	Nozzle Size	A(mm)	40(at 4,000mAq)					
		B(inch)	1 1/2(at 4,000mAq)					
	Cooling	Nm <sup>3</sup> /h	22.9	27.5	34.3	41.2	48.1	54.9
	Heating	Nm <sup>3</sup> /h	30.2	36.3	45.4	54.4	63.6	72.6
Electrical Data	Source	V	3ø 220/380/440V 50/60Hz					
	Total Current	A	11.5	14.3	17.7	17.7	17.7	19.1
	Thickness Wire	mm <sup>2</sup>	4	4	4	4	4	4
	Power	kVA	7.5	9.4	11.7	11.7	11.7	12.6
	Absorbent Pump No.1	kW	1.5	1.5	2.4	2.4	2.4	2.4
		A	5.43	5.43	6.4	6.4	6.4	6.4
	Absorbent Pump No.2	kW	0.4	0.4	1.2	1.2	1.2	1.2
		A	1.6	1.6	4.1	4.1	4.1	4.1
	Refrigerant Pump	kW	0.2	0.2	0.2	0.2	0.2	0.2
		A	1.1	1.1	1.1	1.1	1.1	1.1
	Purge Pump	kW	0.4	0.4	0.4	0.4	0.4	0.4
		A	1.0	1.0	1.0	1.0	1.0	1.0
	BuDHer Blower(Gas)	kW	0.72	1.50	1.50	1.5	1.5	2.2
		A	1.8	4.6	4.6	4.6	4.6	6.0
	Dimension	Length	mm	3,165	3,165	3,745	3,665	3,705
Width		mm	2,000	2,045	2,095	2,095	2,150	2,170
Height		mm	2,070	2,070	2,070	2,070	2,415	2,415
Rigging	Operating	ton	5.1	5.5	6.6	7.0	8.4	8.9
	Total Shipping	ton	4.6	5.0	5.9	6.3	7.6	8.0
	Max Shipping	ton	3.8	4.1	4.8	5.1	6.2	6.5
Flue Connection Size	mm	280 x 210	280 x 210	280 x 210	280 x 210	310 x 310	310 x 310	
Clearance For Tube Removal	mm	2,400	2,400	3,400	3,400	3,400	3,400	

Note:

- 1usRT = 3,024kcal/h, 1kW = 860kcal/h
- Standard inlet water & outlet water Temperature of Chilled water : 12→7°C
- Standard inlet water & outlet water Temperature of Hot water : 56.2→60°C
- Standard inlet water & outlet water Temperature of Cooling water : 32→37°C
- Standard Fouling factor of Chilled & Cooling water : 0.086m<sup>2</sup>K/kW(0.0001m<sup>2</sup>·h·°C)
- Standard Tube and Water Side Pressure(Chiller & Cooling Water Circuit): 10kg/cm<sup>2</sup>G(981kPa)
- Standard gas pressure : 4,000mAq
- Recommend Gas pressure : Low Pressure 200mAq, Mid. Pressure 900mAq, High Pressure 4000mAq
- Standard low calorific power : 9,360 kcal/Nm<sup>3</sup>
- Currents & Electricity Consumptions are based on 3ø 380V 60Hz
- Power supply wire size is based on the due of metal conduit and 40°C of ambient temperature.
- Total Shipping Weight include weight of the burner & liquid.
- The specifications are subject to change without prior notice.
- For other than above this table, contact nearest LG Electronics office.
- Length is the value without the burner attached.

### WCDN Series(Chilled Water 12°C - 7°C COP 1.41)

Model name		WCDN028	WCDN032	WCDN036	WCDN040	WCDN045	WCDN050	
Cooling Capacity	usRT	280	320	360	400	450	500	
	kW	985	1,125	1,266	1,407	1,583	1,758	
Heating Capacity	kcal/h	742,000	849,000	955,000	1,061,000	1,193,000	1,326,000	
	kW	862	987	1,110	1,233	1,387	1,541	
Chilled Water Data	Temperature	°C 12 → 7						
	Water Flow Rate	m <sup>3</sup> /h	169.3	193.5	217.7	241.9	272.2	302.4
	Pressure Drop	mAq	5.6	5.9	6.4	6.5	5.8	5.8
	Connection Size	A(mm)	150	150	150	150	200	200
		B(inch)	6	6	6	6	8	8
Hot Water Data	Temperature	°C 55.6 → 60						
	Water Flow Rate	m <sup>3</sup> /h	169.3	193.5	217.7	241.9	272.2	302.4
	Pressure Drop	mAq	5.6	5.9	6.4	6.5	5.8	5.8
	Connection Size	A(mm)	150	150	150	150	200	200
		B(inch)	6	6	6	6	8	8
Cooling Water Data	Temperature	°C 32 → 37						
	Water Flow Rate	m <sup>3</sup> /h	280	320	360	400	450	500
	Pressure Drop	mAq	5.7	5.9	6.3	6.6	5.7	5.8
	Connection Size	A(mm)	200	200	200	200	250	250
		B(inch)	8	8	8	8	10	10
Fuel(GAS)	Nozzle Size	A(mm)	40(at 4,000mAq)			50(at 4,000mAq)		
		B(inch)	1 1/2(at 4,000mAq)			2(at 4,000mAq)		
	Cooling	Nm <sup>3</sup> /h	64.1	73.3	82.4	91.6	103.0	114.5
	Heating	Nm <sup>3</sup> /h	84.7	96.9	109.0	121.1	136.2	151.3
Electrical Data	Source	V	3ø 220/380/440V 50/60Hz					
	Total Current	A	24.2	24.2	31.2	31.2	33.0	33.0
	Thickness Wire	mm <sup>2</sup>	6	6	10	10	10	10
	Power	kVA	15.9	15.9	20.5	20.5	21.7	21.7
	Absorbent Pump No.1	kW	3.4	3.4	3.4	3.4	3.4	3.4
		A	10.3	10.3	10.3	10.3	10.3	10.3
	Absorbent Pump No.2	kW	1.5	1.5	1.5	1.5	2.0	2.0
		A	5.0	5.0	5.0	5.0	6.8	6.8
	Refrigerant Pump	kW	0.4	0.4	0.4	0.4	0.4	0.4
		A	1.4	1.4	1.4	1.4	1.4	1.4
	Purge Pump	kW	0.4	0.4	0.4	0.4	0.4	0.4
		A	1.0	1.0	1.0	1.0	1.0	1.0
	BuDHer Blower(Gas)	kW	2.2	2.2	5.5	5.5	5.5	5.5
		A	6.0	6.0	13.0	13.0	13.0	13.0
	Dimension	Length	mm	4,725	4,725	4,890	4,890	4,900
Width		mm	2,320	2,260	2,425	2,545	2,840	2,840
Height		mm	2,415	2,415	2,590	2,590	2,925	2,925
Rigging	Operating	ton	10.2	10.8	13.6	14.3	16.6	17.5
	Total Shipping	ton	9.2	9.8	12.1	12.5	14.9	15.5
	Max Shipping	ton	7.4	7.8	9.9	10.1	12.2	12.6
Flue Connection Size	mm	310 x 310	310 x 310	360 x 310	360 x 310	410 x 310	410 x 310	
Clearance For Tube Removal	mm	4,500	4,500	4,500	4,500	4,500	4,500	

Note:

- 1usRT = 3,024kcal/h, 1kW = 860kcal/h
- Standard inlet water & outlet water Temperature of Chilled water : 12→7°C
- Standard inlet water & outlet water Temperature of Hot water : 56.2→60°C
- Standard inlet water & outlet water Temperature of Cooling water : 32→37°C
- Standard Fouling factor of Chilled & Cooling water : 0.086m<sup>2</sup>K/kW(0.0001m<sup>2</sup>·h·°C)
- Standard Tube and Water Side Pressure(Chiller & Cooling Water Circuit): 10kg/cm<sup>2</sup>G(981kPa)
- Standard gas pressure : 4,000mAq
- Recommend Gas pressure : Low Pressure 200mAq, Mid. Pressure 900mAq, High Pressure 4000mAq
- Standard low calorific power : 9,360 kcal/Nm<sup>3</sup>
- Currents & Electricity Consumptions are based on 3ø 380V 60Hz
- Power supply wire size is based on the due of metal conduit and 40°C of ambient temperature.
- Total Shipping Weight include weight of the burner & liquid.
- The specifications are subject to change without prior notice.
- For other than above this table, contact nearest LG Electronics office.
- Length is the value without the burner attached.

### WCDN Series(Chilled Water 12°C - 7°C COP 1.41)

Model name		WCDN056	WCDN063	WCDN070	WCDN080	WCDN090	WCDN100	
Cooling Capacity	usRT	560	630	700	800	900	1,000	
	kW	1,969	2,216	2,462	2,813	3,165	3,517	
Heating Capacity	kcal/h	1,485,000	1,671,000	1,856,000	2,121,000	2,390,000	2,656,000	
	kW	1,726	1,942	2,157	2,465	2,778	3,087	
Chilled Water Data	Temperature	°C 12 → 7						
	Water Flow Rate	m <sup>3</sup> /h	338.7	381	423.4	483.8	544.3	604.8
	Pressure Drop	mAq	5.7	7.9	10.5	13.0	5.7	7.5
	Connection Size	A(mm)	200	200	200	250	250	250
		B(inch)	8	8	8	10	10	10
Hot Water Data	Temperature	°C 55.6 → 60						
	Water Flow Rate	m <sup>3</sup> /h	338.7	381.0	423.4	483.8	544.3	604.8
	Pressure Drop	mAq	5.7	7.9	10.5	13.0	5.7	7.5
	Connection Size	A(mm)	200	200	200	250	250	250
		B(inch)	8	8	8	10	10	10
Cooling Water Data	Temperature	°C 32 → 37						
	Water Flow Rate	m <sup>3</sup> /h	560	630	700	800	900	1,000
	Pressure Drop	mAq	4.8	6.5	8.6	5.5	7.4	9.8
	Connection Size	A(mm)	300	300	300	350	350	350
		B(inch)	12	12	12	14	14	14
Fuel(GAS)	Nozzle Size	A(mm)	50(at 4,000mmAq)					
		B(inch)	2(at 4,000mmAq)					
	Cooling	Nm <sup>3</sup> /h	128.2	144.2	160.3	183.2	206.1	229.0
	Heating	Nm <sup>3</sup> /h	169.5	190.7	211.8	242.1	272.8	303.1
Electrical Data	Source	V	3ø 220/380/440V 50/60Hz					
	Total Current	A	39.2	41.6	41.6	47.0	52.0	52.0
	Thickness Wire	mm <sup>2</sup>	16	16	16	16	25	35
	Power	kVA	25.8	27.4	27.4	30.9	34.2	34.2
	Absorbent Pump No.1	kW	6.6	6.6	6.6	5.5	7.5	7.5
		A	16.2	16.2	16.2	20.0	25.0	25.0
	Absorbent Pump No.2	kW	2.0	2.0	2.0	2.2	2.2	2.2
		A	6.8	6.8	6.8	5.8	5.8	5.8
	Refrigerant Pump	kW	0.4	0.4	0.4	1.5	1.5	1.5
		A	1.4	1.4	1.4	4.0	4.0	4.0
	Purge Pump	kW	0.4	0.4	0.4	0.4	0.4	0.4
		A	1.0	1.0	1.0	1.0	1.0	1.0
	BuDHer Blower(Gas)	kW	5.5	7.5	7.5	7.5	7.5	11.0
		A	13.0	15.4	15.4	15.4	15.4	15.4
	Dimension	Length	mm	5,050	5,495	6,005	5,635	6,160
Width		mm	3,350	3,275	3,255	3,945	4,140	3,920
Height		mm	3,295	3,295	3,295	3,600	3,600	3,600
Rigging	Operating	ton	22.8	24.3	26.6	32.7	37.5	40.5
	Total Shipping	ton	19.1	20.7	22.2	28.0	30.8	32.9
	Max Shipping	ton	15.9	17.1	18.3	23.0	24.7	26.7
Flue Connection Size	mm	500x350	500x350	500 x 350	620 x 400	620 x 400	620 x 400	
Clearance For Tube Removal	mm	4,500	5,200	5,700	5,200	5,700	6,200	

- Note:
- 1.usRT = 3,024kcal/h, 1kW = 860kcal/h
  - Standard inlet water & outlet water Temperature of Chilled water : 12→7°C
  - Standard inlet water & outlet water Temperature of Hot water : 56.2→60°C
  - Standard inlet water & outlet water Temperature of Cooling water : 32→37°C
  - Standard Fouling factor of Chilled & Cooling water : 0.086m<sup>2</sup>K/kW(0.0001m<sup>2</sup>.h.°C)
  - Standard Tube and Water Side Pressure(Chiller & Cooling Water Circuit): 10kg/cm<sup>2</sup>G(981kPa)
  - Standard gas pressure : 4,000mmAq
  - Recommend Gas pressure : Low Pressure 200mmAq, Mid. Pressure 900mmAq, High Pressure 4000mmAq
  - Standard low calorific power : 9,360 kcal/Nm<sup>3</sup>
  - Currents & Electricity Consumptions are based on 3ø 380V 60Hz
  - Power supply wire size is based on the due of metal conduit and 40°C of ambient temperature.
  - Total Shipping Weight include weight of the burner & liquid.
  - The specifications are subject to change without prior notice.
  - For other than above this table, contact nearest LG Electronics office.
  - Length is the value without the burner attached.

### WCDN Series(Chilled Water 12°C - 7°C COP 1.41)

Model name		WCDN110	WCDN120	WCDN130	WCDN140	WCDN150	
Cooling Capacity	usRT	1,100	1,200	1,300	1,400	1,500	
	kW	3,869	4,220	4,572	4,924	5,275	
Heating Capacity	kcal/h	2,922,000	3,187,000	3,453,000	3,719,000	3,984,000	
	kW	3,396	3,704	4,013	4,322	4,630	
Chilled Water Data	Temperature	°C 12 → 7					
	Water Flow Rate	m <sup>3</sup> /h	665.3	725.8	786.2	846.7	907.2
	Pressure Drop	mAq	5.6	7.1	8.9	7.6	9.3
	Connection Size	A(mm)	300	300	300	350	350
		B(inch)	12	12	12	14	14
Hot Water Data	Temperature	°C 55.6 → 60					
	Water Flow Rate	m <sup>3</sup> /h	665.3	725.8	786.2	846.7	907.2
	Pressure Drop	mAq	5.6	7.1	8.9	7.6	9.3
	Connection Size	A(mm)	300	300	300	350	350
		B(inch)	12	12	12	14	14
Cooling Water Data	Temperature	°C 32 → 37					
	Water Flow Rate	m <sup>3</sup> /h	1,100	1,200	1,300	1,400	1,500
	Pressure Drop	mAq	7.5	9.5	11.9	9.8	12.0
	Connection Size	A(mm)	400	400	400	400	400
		B(inch)	16	16	16	16	16
Fuel(GAS)	Nozzle Size	A(mm)	65(at 4,000mmAq)				
		B(inch)	2 1/2(at 4,000mmAq)				
	Cooling	Nm <sup>3</sup> /h	251.8	274.7	297.6	320.5	343.4
	Heating	Nm <sup>3</sup> /h	333.5	363.7	394.1	424.4	454.7
Electrical Data	Source	V	3ø 220/380/440V 50/60Hz				
	Total Current	A	73.1	73.1	73.1	73.1	85.8
	Thickness Wire	mm <sup>2</sup>	35	35	35	35	35
	Power	kVA	48.1	48.1	48.1	48.1	56.5
	Absorbent Pump No.1	kW	7.5	7.5	7.5	7.5	7.5
		A	25.0	25.0	25.0	25.0	25.0
	Absorbent Pump No.2	kW	5.5	5.5	5.5	5.5	5.5
		A	20.0	20.0	20.0	20.0	20.0
	Refrigerant Pump	kW	1.5	1.5	1.5	1.5	1.5
		A	4.0	4.0	4.0	4.0	4.0
	Purge Pump	kW	0.4	0.4	0.4	0.4	0.4
		A	1.0	1.0	1.0	1.0	1.0
	BuDHer Blower(Gas)	kW	11.0	11.0	11.0	15.0	15.0
		A	22.3	22.3	22.3	22.3	35.0
	Dimension	Length	mm	6,140	6,800	7,160	6,800
Width		mm	4,530	4,500	4,500	4,700	4,850
Height		mm	3,800	3,800	3,800	4,040	4,040
Rigging	Operating	ton	48.9	54.5	60.7	63.8	70.4
	Total Shipping	ton	37.2	40.5	42.9	47.9	51.3
	Max Shipping	ton	29.5	31.4	33.2	37.1	39.6
Flue Connection Size	mm	900 x 400	900 x 400	900 x 400	900 x 400	900 x 400	
Clearance For Tube Removal	mm	5,700	6,200	6,700	6,200	6,700	

- Note:
- 1.usRT = 3,024kcal/h, 1kW = 860kcal/h
  - Standard inlet water & outlet water Temperature of Chilled water : 12→7°C
  - Standard inlet water & outlet water Temperature of Hot water : 56.2→60°C
  - Standard inlet water & outlet water Temperature of Cooling water : 32→37°C
  - Standard Fouling factor of Chilled & Cooling water : 0.086m<sup>2</sup>K/kW(0.0001m<sup>2</sup>.h.°C)
  - Standard Tube and Water Side Pressure(Chiller & Cooling Water Circuit): 10kg/cm<sup>2</sup>G(981kPa)
  - Standard gas pressure : 4,000mmAq
  - Recommend Gas pressure : Low Pressure 200mmAq, Mid. Pressure 900mmAq, High Pressure 4000mmAq
  - Standard low calorific power : 9,360 kcal/Nm<sup>3</sup>
  - Currents & Electricity Consumptions are based on 3ø 380V 60Hz
  - Power supply wire size is based on the due of metal conduit and 40°C of ambient temperature.
  - Total Shipping Weight include weight of the burner & liquid.
  - The specifications are subject to change without prior notice.
  - For other than above this table, contact nearest LG Electronics office.
  - Length is the value without the burner attached.

## WCSH Series(Chilled Water 12°C - 7°C COP 1.51)

Model name		WCSH010	WCSH012	WCSH015	WCSH018	WCSH021	WCSH024	
Cooling Capacity	usRT	100	120	150	180	210	240	
	kW	352	422	528	633	739	844	
Chilled water data	Temperature	°C 12 → 7						
	Water Flow Rate	m³/h	60.5	72.6	90.7	108.9	127	145.2
	Pressure Drop	mAq	7.7	7.7	9.9	10.0	9.3	9.7
	Connection Size	A	100	100	100	100	125	125
		B(inch)	4	4	4	4	5	5
Cooling Water Data	Temperature	°C 32 → 37						
	Water Flow Rate	m³/h	100	120	150	180	210	240
	Pressure Drop	mAq	5.2	4.9	8.4	8.9	7.2	7.6
	Connection Size	A	125	125	125	125	150	150
B(inch)		5	5	5	5	6	6	
Fuel	Steam Flow Rate	kg/h	350	420	525	630	735	840
	Steam Inlet Connection	A	50	50	50	50	50	50
		B(inch)	2	2	2	2	2	2
	Drain Outlet Connection	A	25	25	25	25	25	25
		B(inch)	1	1	1	1	1	1
	Steam Control Valve	A	25	25	40	40	40	40
B(inch)		1	1	1.5	1.5	1.5	1.5	
Electrical data	Source	V	3ø 220/380/440V 50/60Hz					
	Total Current	A	9.2	9.2	10.1	10.1	10.1	10.1
	Thickness Wire	mm²	4	4	4	4	4	4
	Power	kVA	6.3	6.3	7.0	7.0	7.0	7.0
Pump data	Absorbent Pump No.1	kW	1.5	1.5	2.4	2.4	2.4	2.4
		A	5.4	5.4	6.4	6.4	6.4	6.4
	Absorbent Pump No.2	kW	0.2	0.2	0.2	0.2	0.2	0.2
		A	1.1	1.1	1.1	1.1	1.1	1.1
	Refrigerant Pump	kW	0.2	0.2	0.2	0.2	0.2	0.2
		A	1.1	1.1	1.1	1.1	1.1	1.1
	Purge Pump	kW	0.4	0.4	0.4	0.4	0.4	0.4
		A	1.0	1.0	1.0	1.0	1.0	1.0
Dimension	Length	mm	2,750	2,750	3,720	3,720	3,720	3,720
	Width	mm	1,930	1,930	1,930	1,930	2,000	2,000
	Height	mm	2,065	2,065	2,070	2,110	2,415	2,415
Rigging	Operating	ton	4.5	4.9	5.8	6.4	7.7	8.1
	Total Shipping	ton	3.5	3.8	4.4	4.8	5.7	6.0
	Max Shipping	ton	4.1	4.5	5.3	5.9	6.8	7.3
Clearance For Tube Removal	mm	2,400	2,400	3,400	3,400	3,400	3,400	

- Note:
- 1usRT = 3,024kcal/h, 1kW = 860kcal/h
  - Standard inlet water & outlet water Temperature of Chilled water : 12→7°C
  - Standard inlet water & outlet water Temperature of Cooling water : 32→37°C
  - Standard Fouling factor of Chilled & Cooling water : 0.086m²K/kW(0.0001m².h.°C)
  - Standard Tube and Water Side Pressure(Chiller & Cooling Water Circuit): 10kg/cm²G(981kPa)
  - Standard Steam Pressure: 8kg/cm²G(785kPa)
  - Currents & Electricity Consumptions are based on 3ø 380V 60Hz
  - Power supply wire size is based on the due of metal conduit and 40°C of ambient temperature.
  - Total Shipping Weight include weight of the burner & liquid.
  - The specifications are subject to change without prior notice.
  - For other than above this table, contact nearest LG Electronics office.

## WCSH Series(Chilled Water 12°C - 7°C COP 1.51)

Model name		WCSH028	WCSH032	WCSH036	WCSH040	WCSH045	WCSH050	
Cooling Capacity	usRT	280	320	360	400	450	500	
	kW	985	1,125	1,266	1,407	1,583	1,758	
Chilled water data	Temperature	°C 12 → 7						
	Water Flow Rate	m³/h	169.3	193.5	217.7	241.9	272.2	302.4
	Pressure Drop	mAq	6.2	6.5	7.0	7.1	6.3	6.4
	Connection Size	A	150	150	150	150	200	200
		B(inch)	6	6	6	6	8	8
Cooling Water Data	Temperature	°C 32 → 37						
	Water Flow Rate	m³/h	280	320	360	400	450	500
	Pressure Drop	mAq	6.5	6.7	7.1	7.4	6.6	6.7
	Connection Size	A	200	200	200	200	250	250
B(inch)		8	8	8	8	10	10	
Fuel	Steam Flow Rate	kg/h	980	1,120	1,260	1,400	1,575	1,750
	Steam Inlet Connection	A	65	65	80	80	80	80
		B(inch)	3	3	3	3	3	3
	Drain Outlet Connection	A	25	25	40	40	40	40
		B(inch)	1	1	1.5	1.5	1.5	1.5
	Steam Control Valve	A	40	50	50	50	50	50
B(inch)		1.5	2	2	2	2	2	
Electrical data	Source	V	3ø 220/380/440V 50/60Hz					
	Total Current	A	15.0	15.0	14.6	14.6	16.3	16.3
	Thickness Wire	mm²	4	4	4	4	4	4
	Power	kVA	10.2	10.2	9.9	9.9	11.0	11.0
Pump data	Absorbent Pump No.1	kW	3.4	3.4	3.4	3.4	3.7	3.7
		A	10.3	10.3	10.3	10.3	12.0	12.0
	Absorbent Pump No.2	kW	0.4	0.4	0.4	0.4	0.4	0.4
		A	1.4	1.4	1.4	1.4	1.4	1.4
	Refrigerant Pump	kW	0.4	0.4	0.4	0.4	0.4	0.4
		A	1.8	1.8	1.4	1.4	1.4	1.4
	Purge Pump	kW	0.4	0.4	0.4	0.4	0.4	0.4
		A	1.0	1.0	1.0	1.0	1.0	1.0
Dimension	Length	mm	4,740	4,740	4,800	4,800	4,830	4,830
	Width	mm	2,070	2,070	2,200	2,200	2,445	2,445
	Height	mm	2,415	2,415	2,590	2,590	2,950	2,950
Rigging	Operating	ton	9.5	9.8	11.9	13.0	14.3	16.5
	Total Shipping	ton	6.9	7.1	8.6	9.6	10.4	12.2
	Max Shipping	ton	8.5	8.6	10.5	11.5	12.5	14.5
Clearance For Tube Removal	mm	4,500	4,500	4,500	4,500	4,500	4,500	

- Note:
- 1usRT = 3,024kcal/h, 1kW = 860kcal/h
  - Standard inlet water & outlet water Temperature of Chilled water : 12→7°C
  - Standard inlet water & outlet water Temperature of Cooling water : 32→37°C
  - Standard Fouling factor of Chilled & Cooling water : 0.086m²K/kW(0.0001m².h.°C)
  - Standard Tube and Water Side Pressure(Chiller & Cooling Water Circuit): 10kg/cm²G(981kPa)
  - Standard Steam Pressure: 8kg/cm²G(785kPa)
  - Currents & Electricity Consumptions are based on 3ø 380V 60Hz
  - Power supply wire size is based on the due of metal conduit and 40°C of ambient temperature.
  - Total Shipping Weight include weight of the burner & liquid.
  - The specifications are subject to change without prior notice.
  - For other than above this table, contact nearest LG Electronics office.

### WCSH Series(Chilled Water 12°C - 7°C COP 1.51)

Model name		WCSH056	WCSH063	WCSH070	WCSH080	WCSH090	WCSH100	
Cooling Capacity	usRT	560	630	700	800	900	1,000	
	kW	1,969	2,216	2,462	2,813	3,165	3,517	
Chilled water data	Temperature	°C 12 → 7						
	Water Flow Rate	m³/h 338.7	381	423.4	483.8	544.3	604.8	
	Pressure Drop	mAq 6.3	8.7	11.6	10.2	13.9	6.0	
	Connection Size	A	200	200	200	250	250	250
		B(inch)	8	8	8	10	10	10
Cooling Water Data	Temperature	°C 32 → 37						
	Water Flow Rate	m³/h 560	630	700	800	900	1,000	
	Pressure Drop	mAq 5.7	7.8	10.2	6.1	8.2	10.8	
	Connection Size	A	300	300	300	350	350	350
		B(inch)	12	12	12	14	14	14
Fuel	Steam Flow Rate	kg/h 1,960	2,205	2,450	2,800	3,150	3,500	
	Steam Inlet Connection	A	100	100	100	125	125	125
		B(inch)	4	4	4	5	5	5
	Drain Outlet Connection	A	50	50	50	65	65	65
		B(inch)	2	2	2	2.5	2.5	2.5
	Steam Control Valve	A	65	65	65	65	80	80
B(inch)		2.5	2.5	2.5	2.5	3	3	
Electrical data	Source	V 3ø 220/380/440V 50/60Hz						
	Total Current	A 21.2	21.2	21.2	29.3	34.3	34.3	
	Thickness Wire	mm² 4	4	4	4	10	10	
	Power	kVA 14.5	14.5	14.5	19.8	23.1	23.1	
Pump data	Absorbent Pump No.1	kW 6.6	6.6	6.6	5.5	7.5	7.5	
		A 16.2	16.2	16.2	20.0	25.0	25.0	
	Absorbent Pump No.2	kW 0.4	0.4	0.4	1.5	1.5	1.5	
		A 1.4	1.4	1.4	4.0	4.0	4.0	
	Refrigerant Pump	kW 0.4	0.4	0.4	1.3	1.3	1.3	
		A 1.8	1.8	1.8	3.5	3.5	3.5	
	Purge Pump	kW 0.4	0.4	0.4	0.4	0.4	0.4	
		A 1.0	1.0	1.0	1.0	1.0	1.0	
Dimension	Length	mm 4,985	5,485	5,985	5,635	6,130	6,590	
	Width	mm 2,610	2,610	2,610	3,090	3,090	3,090	
	Height	mm 3,300	3,300	3,300	3,550	3,550	3,550	
Rigging	Operating	ton 20.4	21.7	25.1	29.4	31.7	35.4	
	Total Shipping	ton 15.0	15.6	18.2	19.8	21.5	23.7	
	Max Shipping	ton 17.6	18.7	21.8	25.1	27.1	30.6	
Clearance For Tube Removal	mm	4,500	5,200	5,700	5,200	5,700	6,200	

- Note:
- 1usRT = 3,024kcal/h, 1kW = 860kcal/h
  - Standard inlet water & outlet water Temperature of Chilled water : 12→7°C
  - Standard inlet water & outlet water Temperature of Cooling water : 32→37°C
  - Standard Fouling factor of Chilled & Cooling water : 0.086m²K/kW(0.0001m².h.°C)
  - Standard Tube and Water Side Pressure(Chiller & Cooling Water Circuit): 10kg/cm²G(981kPa)
  - Standard Steam Pressure: 8kg/cm²G(785kPa)
  - Currents & Electricity Consumptions are based on 3ø 380V 60Hz
  - Power supply wire size is based on the due of metal conduit and 40°C of ambient temperature.
  - Total Shipping Weight include weight of the burner & liquid.
  - The specifications are subject to change without prior notice.
  - For other than above this table, contact nearest LG Electronics office.

### WCSH Series(Chilled Water 12°C - 7°C COP 1.51)

Model name		WCSH110	WCSH120	WCSH130	WCSH140	WCSH150	
Cooling Capacity	usRT	1,100	1,200	1,300	1,400	1,500	
	kW	3,869	4,220	4,572	4,924	5,275	
Chilled water data	Temperature	°C 12 → 7					
	Water Flow Rate	m³/h 665.3	725.8	786.2	846.7	907.2	
	Pressure Drop	mAq 5.6	7.1	8.9	7.6	9.3	
	Connection Size	A	300	300	300	350	350
		B(inch)	12	12	12	14	14
Cooling Water Data	Temperature	°C 32 → 37					
	Water Flow Rate	m³/h 1,100	1,200	1,300	1,400	1,500	
	Pressure Drop	mAq 8.3	10.6	13.2	10.9	13.3	
	Connection Size	A	400	400	400	400	400
		B(inch)	16	16	16	16	16
Fuel	Steam Flow Rate	kg/h 3,850	4,200	4,550	4,900	5,250	
	Steam Inlet Connection	A	150	150	150	150	150
		B(inch)	6	6	6	6	6
	Drain Outlet Connection	A	80	80	80	80	80
		B(inch)	3	3	3	3	3
	Steam Control Valve	A	80	80	80	100	100
B(inch)		3	3	3	4	4	
Electrical data	Source	V 3ø 220/380/440V 50/60Hz					
	Total Current	A 34.3	34.3	34.3	34.3	34.3	
	Thickness Wire	mm² 16	16	16	16	16	
	Power	kVA 23.1	23.1	23.1	23.1	23.1	
Pump data	Absorbent Pump No.1	kW 7.5	7.5	7.5	7.5	7.5	
		A 25.0	25.0	25.0	25.0	25.0	
	Absorbent Pump No.2	kW 1.5	1.5	1.5	1.5	1.5	
		A 4.0	4.0	4.0	4.0	4.0	
	Refrigerant Pump	kW 1.3	1.3	1.3	1.3	1.3	
		A 3.5	3.5	3.5	3.5	3.5	
	Purge Pump	kW 0.4	0.4	0.4	0.4	0.4	
		A 1.0	1.0	1.0	1.0	1.0	
Dimension	Length	mm 6,140	6,660	7,160	6,860	7,360	
	Width	mm 3,180	3,180	3,180	3,520	3,520	
	Height	mm 3,820	3,820	3,820	3,840	3,840	
Rigging	Operating	ton 40.5	44.8	48.8	54.6	58.6	
	Total Shipping	ton 27.7	30.4	32.7	36.7	39.2	
	Max Shipping	ton 35.6	39.6	43.2	48.4	52.1	
Clearance For Tube Removal	mm	5,700	6,200	6,700	6,200	6,700	

- Note:
- 1usRT = 3,024kcal/h, 1kW = 860kcal/h
  - Standard inlet water & outlet water Temperature of Chilled water : 12→7°C
  - Standard inlet water & outlet water Temperature of Cooling water : 32→37°C
  - Standard Fouling factor of Chilled & Cooling water : 0.086m²K/kW(0.0001m².h.°C)
  - Standard Tube and Water Side Pressure(Chiller & Cooling Water Circuit): 10kg/cm²G(981kPa)
  - Standard Steam Pressure: 8kg/cm²G(785kPa)
  - Currents & Electricity Consumptions are based on 3ø 380V 60Hz
  - Power supply wire size is based on the due of metal conduit and 40°C of ambient temperature.
  - Total Shipping Weight include weight of the burner & liquid.
  - The specifications are subject to change without prior notice.
  - For other than above this table, contact nearest LG Electronics office.

### WCMH Series(Chilled Water 12°C - 7°C COP 0.81, IPLV 0.84)

Model name		WCMH008	WCMH009	WCMH011	WCMH014	WCMH016	WCMH018	WCMH021	
Cooling Capacity	USRT	80	90	110	140	160	180	210	
	kW	258	309	378	464	532	618	721	
Chilled Water Data	Temperature	°C 12 → 7							
	Water Flow Rate	m <sup>3</sup> /h	48.4	54.4	66.5	84.7	96.8	108.9	127.0
	Pressure Drop	mAq	9.8	8.7	5.3	6.1	5.4	5.5	3.7
	Connection Size	B(inch)	3	3	4	4	5	5	5
Cooling Water Data	Temperature	°C 32 → 37							
	Water Flow Rate	m <sup>3</sup> /h	108.1	121.6	148.7	189.2	216.2	243.3	283.8
	Pressure Drop	mAq	4.7	4.8	8.6	10.2	7.6	7.8	13.4
	Connection Size	B(inch)	4	4	5	5	6	6	8
Hot Water Data	Temperature	°C 95 → 72							
	Water Flow Rate	ton/h	13.0	14.6	17.9	22.7	26.0	29.2	34.1
	Pressure Drop	mAq	5.9	5.3	4.9	5.6	5.7	5.5	5.6
	Pressure Drop(Valve)	mAq	2.7	2.2	2.0	2.1	2.7	2.2	2.9
	Connection Size	B(inch)	2	2	2 1/2	2 1/2	3	3	3
	Connection Size(Valve)	DN	40	50	50	50	65	65	65
Electrical Data	Source	V	3ø 220/380/440V 50/60Hz						
	Total Current	A	7.7	7.7	9.1	9.1	9.1	9.1	15.1
	Wire Size	mm <sup>2</sup>	4	4	4	4	4	4	4
	Power	kVA	5.1	5.1	6.0	6.0	6.0	6.0	9.9
	Absorbent Pump(Main)	kW	1.2	1.2	1.5	1.5	1.5	1.5	2.4
		A	3.5	3.5	4.6	4.6	4.6	4.6	7.5
	Absorbent Pump(Sub)	kW	0.4	0.4	0.4	0.4	0.4	0.4	1.5
		A	1.6	1.6	1.6	1.6	1.6	1.6	4.6
	Refrigerant Pump	kW	0.2	0.2	0.3	0.3	0.3	0.3	0.4
		A	1.1	1.1	1.4	1.4	1.4	1.4	1.5
Purge Pump	kW	0.4	0.4	0.4	0.4	0.4	0.4	0.4	
	A	1.0	1.0	1.0	1.0	1.0	1.0	1.0	
Dimension	Length	mm	2,790	2,790	3,700	3,700	3,850	3,850	4,870
	Width	mm	1,600	1,600	1,500	1,500	1,560	1,560	1,560
	Height	mm	2,370	2,370	2,370	2,370	2,715	2,715	2,715
Rigging	Operating	ton	4.2	4.4	5.2	5.6	6.8	7.2	8.2
	Max. Shipping	ton	3.0	3.1	3.6	3.8	4.8	5.0	5.8
	Total Shipping	ton	3.5	3.7	4.4	4.7	5.8	6.1	7.0
Clearance For Tube Removal	mm	2,400	2,400	3,400	3,400	3,400	3,400	4,500	

Note:

- 1 usRT = 3,024kcal/h, 1kW = 860kcal/h
- Standard Tube and Water Side Pressure(Chiller & Cooling Water Circuit): 10kg/cm<sup>2</sup>G(981kPa)
- Currents & Electricity Consumptions are based on 3ø 380V 60Hz
- Alternate cooling water temperature range available upon request.
- Power supply wire size is based on the due of metal conduit and 40°C of ambient temperature.
- The specifications are subject to change without prior notice.
- For other than above this table, contact nearest LG Electronics office.

### WCMH Series(Chilled Water 12°C - 7°C COP 0.81, IPLV 0.84)

Model name		WCMH024	WCMH027	WCMH030	WCMH034	WCMH038	WCMH042	
Cooling Capacity	USRT	240	270	300	340	380	420	
	kW	824	927	1,030	1,167	1,288	1,442	
Chilled Water Data	Temperature	°C 12 → 7						
	Water Flow Rate	m <sup>3</sup> /h	145.2	163.3	181.4	205.6	229.8	254.0
	Pressure Drop	mAq	4.0	3.9	4.0	4.1	4.2	3.5
	Connection Size	B(inch)	5	6	6	6	6	8
Cooling Water Data	Temperature	°C 32 → 37						
	Water Flow Rate	m <sup>3</sup> /h	324.4	364.9	405.4	459.5	513.6	567.6
	Pressure Drop	mAq	13.6	7.7	8.0	7.3	7.5	6.9
	Connection Size	B(inch)	8	8	8	10	10	10
Hot Water Data	Temperature	°C 95 → 72						
	Water Flow Rate	ton/h	39.0	43.8	48.7	55.2	61.7	68.2
	Pressure Drop	mAq	5.6	5.5	5.5	5.6	5.7	3.1
	Pressure Drop(Valve)	mAq	2.4	1.9	2.4	1.4	1.7	2.1
	Connection Size	B(inch)	3	4	4	4	4	5
	Connection Size(Valve)	DN	80	80	80	100	100	100
Electrical Data	Source	V	3ø 220/380/440V 50/60Hz					
	Total Current	A	15.1	15.1	15.1	19.8	19.8	19.8
	Wire Size	mm <sup>2</sup>	4	4	4	4	4	4
	Power	kVA	9.9	9.9	9.9	13.0	13.0	13.0
	Absorbent Pump(Main)	kW	2.4	2.4	2.4	3.4	3.4	3.4
		A	7.5	7.5	7.5	10.0	10.0	10.0
	Absorbent Pump(Sub)	kW	1.5	1.5	1.5	2.0	2.0	2.0
		A	4.6	4.6	4.6	6.8	6.8	6.8
	Refrigerant Pump	kW	0.4	0.4	0.4	0.4	0.4	0.4
		A	1.5	1.5	1.5	1.5	1.5	1.5
Purge Pump	kW	0.4	0.4	0.4	0.4	0.4	0.4	
	A	1.0	1.0	1.0	1.0	1.0	1.0	
Dimension	Length	mm	4,870	4,860	4,860	4,940	4,940	4,940
	Width	mm	1,560	1,800	1,800	1,940	1,940	2,045
	Height	mm	2,715	2,970	2,970	3,330	3,330	3,540
Rigging	Operating	ton	8.4	11.0	11.4	14.0	14.4	16.6
	Max. Shipping	ton	6.0	7.9	8.1	9.6	9.8	12.0
	Total Shipping	ton	7.3	9.3	9.6	11.4	11.8	14.0
Clearance For Tube Removal	mm	4,500	4,500	4,500	4,500	4,500	4,500	

Note:

- 1 usRT = 3,024kcal/h, 1kW = 860kcal/h
- Standard Tube and Water Side Pressure(Chiller & Cooling Water Circuit): 10kg/cm<sup>2</sup>G(981kPa)
- Currents & Electricity Consumptions are based on 3ø 380V 60Hz
- Alternate cooling water temperature range available upon request.
- Power supply wire size is based on the due of metal conduit and 40°C of ambient temperature.
- The specifications are subject to change without prior notice.
- For other than above this table, contact nearest LG Electronics office.

### WCMH Series(Chilled Water 12°C - 7°C COP 0.81, IPLV 0.84)

Model name		WCMH047	WCMH053	WCMH060	WCMH068	WCMH075	WCMH083	
Cooling Capacity	USRT	470	530	600	680	750	830	
	kW	1,614	1,803	2,060	2,318	2,573	2,833	
Chilled Water Data	Temperature	12 → 7						
	Water Flow Rate	m <sup>3</sup> /h	284.3	320.5	362.9	411.3	453.6	502.0
	Pressure Drop	mAq	4.8	6.6	5.7	7.9	10.3	3.2
	Connection Size	B(inch)	8	8	10	10	10	12
Cooling Water Data	Temperature	32 → 37						
	Water Flow Rate	m <sup>3</sup> /h	635.2	716.3	810.9	919.0	1,013.6	1,121.7
	Pressure Drop	mAq	9.2	12.4	7.2	9.7	12.5	10.3
	Connection Size	B(inch)	10	10	12	12	12	14
Hot Water Data	Temperature	95 → 72						
	Water Flow Rate	ton/h	76.3	86.0	97.4	110.4	121.7	134.7
	Pressure Drop	mAq	4.4	5.9	2.2	3.1	4.1	3.2
	Pressure Drop(Valve)	mAq	2.6	1.5	2.0	2.5	1.5	1.8
	Connection Size	B(inch)	5	5	6	6	6	6
	Connection Size(Valve)	DN	100	125	125	125	150	150
Electrical Data	Source	V	3ø 220/380/440V 50/60Hz					
	Total Current	A	19.8	25.4	27.9	27.9	27.9	37.5
	Wire Size	mm <sup>2</sup>	4	6	6	6	6	10
	Power	kVA	13.0	16.7	18.4	18.4	18.4	24.7
	Absorbent Pump(Main)	kW	3.4	4.5	4.5	4.5	4.5	4.5
		A	10.0	16.0	16.0	16.0	16.0	16.0
	Absorbent Pump(Sub)	kW	2.0	2.2	2.2	2.2	2.2	4.5
		A	6.8	6.4	6.4	6.4	6.4	16.0
	Refrigerant Pump	kW	0.4	0.4	1.5	1.5	1.5	1.5
		A	1.5	1.5	4.0	4.0	4.0	4.0
	Purge Pump	kW	0.4	0.4	0.4	0.4	0.4	0.4
A		1.0	1.0	1.0	1.0	1.0	1.0	
Dimension	Length	mm	5,480	5,980	5,700	6,200	6,730	6,270
	Width	mm	2,045	2,045	2,340	2,340	2,340	4,200
	Height	mm	3,540	3,540	3,900	3,900	3,900	3,000
Rigging	Operating	ton	18.0	19.2	26.6	28.4	31.0	33.2
	Max. Shipping	ton	12.9	13.8	18.5	19.4	21.0	24.5
	Total Shipping	ton	15.4	16.6	21.8	23.1	25.1	29.7
Clearance For Tube Removal	mm	5,200	5,700	5,200	5,700	6,200	5,700	

Note:

- 1 usRT = 3,024kcal/h, 1kW = 860kcal/h
- Standard Tube and Water Side Pressure(Chiller & Cooling Water Circuit): 10kg/cm<sup>2</sup>G(981kPa)
- Currents & Electricity Consumptions are based on 3ø 380V 60Hz
- Alternate cooling water temperature range available upon request.
- Power supply wire size is based on the due of metal conduit and 40°C of ambient temperature.
- The specifications are subject to change without prior notice.
- For other than above this table, contact nearest LG Electronics office.

### WCMH Series(Chilled Water 12°C - 7°C COP 0.81, IPLV 0.84)

Model name		WCMH090	WCMH098	WCMH105	WCMH113	WCMH120	WCMH135	
Cooling Capacity	USRT	900	980	1,050	1,130	1,200	1,350	
	kW	3,090	3,344	3,605	3,863	4,120	4,636	
Chilled Water Data	Temperature	12 → 7						
	Water Flow Rate	m <sup>3</sup> /h	544.3	592.7	635.0	683.4	725.8	816.5
	Pressure Drop	mAq	4.0	5.0	4.4	5.5	6.5	8.7
	Connection Size	B(inch)	12	12	12	12	12	12
Cooling Water Data	Temperature	32 → 37						
	Water Flow Rate	m <sup>3</sup> /h	1,216.3	1,324.4	1,419.0	1,527.2	1,621.8	1,824.5
	Pressure Drop	mAq	12.8	16.0	12.4	15.1	9.4	12.5
	Connection Size	B(inch)	14	14	16	16	18	18
Hot Water Data	Temperature	95 → 72						
	Water Flow Rate	ton/h	146.1	159.1	170.4	183.4	194.8	219.1
	Pressure Drop	mAq	4.1	5.2	3.9	4.9	6.0	6.0
	Pressure Drop(Valve)	mAq	2.2	2.6	2.9	0.8	1.0	1.2
	Connection Size	B(inch)	6	6	8	8	8	8
	Connection Size(Valve)	DN	150	150	150	200	200	200
Electrical Data	Source	V	3ø 220/380/440V 50/60Hz					
	Total Current	A	39.5	39.5	48.5	48.5	48.5	48.5
	Wire Size	mm <sup>2</sup>	16	16	16	16	16	16
	Power	kVA	26.0	26.0	31.9	31.9	31.9	31.9
	Absorbent Pump(Main)	kW	4.5	4.5	7.5	7.5	7.5	7.5
		A	16.0	16.0	25.0	25.0	25.0	25.0
	Absorbent Pump(Sub)	kW	4.5	4.5	4.5	4.5	4.5	4.5
		A	16.0	16.0	16.0	16.0	16.0	16.0
	Refrigerant Pump	kW	1.8	1.8	1.8	1.8	1.8	1.8
		A	6.0	6.0	6.0	6.0	6.0	6.0
	Purge Pump	kW	0.4	0.4	0.4	0.4	0.4	0.4
A		1.0	1.0	1.0	1.0	1.0	1.0	
Dimension	Length	mm	6,795	7,295	6,830	7,330	7,850	8,350
	Width	mm	4,200	4,200	4,410	4,410	4,410	4,410
	Height	mm	3,000	3,000	3,000	3,000	3,000	3,000
Rigging	Operating	ton	36.0	39.0	42.4	44.4	47.8	51.6
	Max. Shipping	ton	26.3	27.8	30.3	32.2	34.8	37.7
	Total Shipping	ton	32.0	34.1	36.4	38.8	42.2	45.9
Clearance For Tube Removal	mm	6,200	6,700	6,200	6,700	7,400	8,000	

Note:

- 1 usRT = 3,024kcal/h, 1kW = 860kcal/h
- Standard Tube and Water Side Pressure(Chiller & Cooling Water Circuit): 10kg/cm<sup>2</sup>G(981kPa)
- Currents & Electricity Consumptions are based on 3ø 380V 60Hz
- Alternate cooling water temperature range available upon request.
- Power supply wire size is based on the due of metal conduit and 40°C of ambient temperature.
- The specifications are subject to change without prior notice.
- For other than above this table, contact nearest LG Electronics office.

### WC2H Series(Chilled Water 12°C - 7°C COP 0.73, IPLV 0.91)

Model name		WC2H008	WC2H009	WC2H011	WC2H014	WC2H016	WC2H018	WC2H021	
Cooling Capacity	USRT	80	90	110	140	160	180	210	
	kW	281	317	387	493	563	633	739	
Chilled Water Data	Temperature	°C 12 → 7							
	Water Flow Rate	m <sup>3</sup> /h	48.4	54.4	66.5	84.7	96.8	108.9	127.0
	Pressure Drop	mAq	11.2	9.6	6.0	6.7	6.1	6.0	4.2
	Connection Size	B(inch)	3	3	4	4	5	5	5
Cooling Water Data	Temperature	°C 32 → 37							
	Water Flow Rate	m <sup>3</sup> /h	114.7	129.0	157.7	200.7	229.3	258.0	301.0
	Pressure Drop	mAq	10.1	9.5	10.4	12.0	6.7	6.8	11.7
	Connection Size	B(inch)	4	4	5	5	6	6	8
Hot Water Data	Temperature	°C 95 → 55							
	Water Flow Rate	ton/h	8.3	9.3	11.4	14.5	16.6	18.6	21.7
	Pressure Drop	mAq	3.6	3.2	5.1	5.6	3.4	3.4	4.0
	Pressure Drop(Valve)	mAq	2.8	1.4	2.1	2.2	2.8	2.2	1.9
	Connection Size	B(inch)	2	2	2 1/2	2 1/2	3	3	3
	Connection Size(Valve)	DN	40	40	40	50	50	50	50
Electrical Data	Source	V	3ø 220/380/440V 50/60Hz						
	Total Current	A	10.7	10.7	12.0	12.0	12.0	12.0	18.6
	Wire Size	mm <sup>2</sup>	4	4	4	4	4	4	4
	Power	kVA	7.0	7.0	7.9	7.9	7.9	7.9	12.2
	Absorbent Pump(Main)	kW	1.7	1.7	1.7	1.7	1.7	1.7	4.1
		A	5.9	5.9	5.9	5.9	5.9	5.9	12.0
	Absorbent Pump(Sub)	kW	0.4	0.4	1.0	1.0	1.0	1.0	1.0
		A	2.2	2.2	3.5	3.5	3.5	3.5	3.5
	Refrigerant Pump	kW	0.2	0.2	0.2	0.2	0.2	0.2	0.4
		A	1.1	1.1	1.1	1.1	1.1	1.1	1.6
	Purge Pump	kW	0.4	0.4	0.4	0.4	0.4	0.4	0.4
A		1.0	1.0	1.0	1.0	1.0	1.0	1.0	
Dimension	Length	mm	2,790	2,790	3,810	3,810	3,850	3,850	4,840
	Width	mm	2,180	2,180	2,090	2,090	2,210	2,210	2,210
	Height	mm	2,310	2,310	2,310	2,310	2,675	2,675	2,675
Rigging	Operating	ton	5.6	5.8	7.0	7.4	9.4	9.8	11.2
	Max. Shipping	ton	4.5	4.7	5.5	5.7	7.3	7.5	8.7
	Total Shipping	ton	5.0	5.2	6.3	6.6	8.3	8.6	9.9
Clearance For Tube Removal	mm	2,400	2,400	3,400	3,400	3,400	3,400	4,500	

Note:

- 1 usRT = 3,024kcal/h, 1kW = 860kcal/h
- Standard Tube and Water Side Pressure(Chiller & Cooling Water Circuit): 10kg/cm<sup>2</sup>G(981kPa)
- Currents & Electricity Consumptions are based on 3ø 380V 60Hz
- Alternate cooling water temperature range available upon request.
- Power supply wire size is based on the due of metal conduit and 40°C of ambient temperature.
- The specifications are subject to change without prior notice.
- For other than above this table, contact nearest LG Electronics office.

### WC2H Series(Chilled Water 12°C - 7°C COP 0.73, IPLV 0.91)

Model name		WC2H024	WC2H027	WC2H030	WC2H034	WC2H038	WC2H042	
Cooling Capacity	USRT	240	270	300	340	380	420	
	kW	844	950	1,056	1,196	1,337	1,478	
Chilled Water Data	Temperature	°C 12 → 7						
	Water Flow Rate	m <sup>3</sup> /h	145.2	163.3	181.4	205.6	229.8	254.0
	Pressure Drop	mAq	4.3	4.2	4.3	4.1	4.0	3.9
	Connection Size	B(inch)	5	6	6	8	8	8
Cooling Water Data	Temperature	°C 32 → 37						
	Water Flow Rate	m <sup>3</sup> /h	344.0	387.0	430.0	487.3	544.7	602.0
	Pressure Drop	mAq	11.7	5.8	6.1	5.3	5.5	5.5
	Connection Size	B(inch)	8	8	8	10	10	10
Hot Water Data	Temperature	°C 95 → 55						
	Water Flow Rate	ton/h	24.9	28.0	31.1	35.2	39.4	43.5
	Pressure Drop	mAq	4.0	4.4	4.4	4.5	4.6	1.9
	Pressure Drop(Valve)	mAq	2.5	2.0	2.5	2.0	2.5	1.9
	Connection Size	B(inch)	3	4	4	4	4	4
	Connection Size(Valve)	DN	65	65	65	80	80	80
Electrical Data	Source	V	3ø 220/380/440V 50/60Hz					
	Total Current	A	18.6	18.6	18.6	24.4	24.4	24.4
	Wire Size	mm <sup>2</sup>	4	4	4	4	4	4
	Power	kVA	12.2	12.2	12.2	16.1	16.1	16.1
	Absorbent Pump(Main)	kW	4.1	4.1	4.1	6.5	6.5	6.5
		A	12.0	12.0	12.0	18.1	18.1	18.1
	Absorbent Pump(Sub)	kW	1.0	1.0	1.0	0.8	0.8	0.8
		A	3.5	3.5	3.5	3.2	3.2	3.2
	Refrigerant Pump	kW	0.4	0.4	0.4	0.4	0.4	0.4
		A	1.6	1.6	1.6	1.6	1.6	1.6
	Purge Pump	kW	0.4	0.4	0.4	0.4	0.4	0.4
A		1.0	1.0	1.0	1.0	1.0	1.0	
Dimension	Length	mm	4,840	4,840	4,840	4,930	4,930	4,955
	Width	mm	2,210	2,500	2,500	2,710	2,710	2,940
	Height	mm	2,675	2,770	2,770	3,120	3,120	3,370
Rigging	Operating	ton	11.8	14.2	14.8	18.4	19.2	22.8
	Max. Shipping	ton	8.9	11.0	11.3	14.4	14.7	17.5
	Total Shipping	ton	10.3	12.4	12.8	16.1	16.7	19.6
Clearance For Tube Removal	mm	4,500	4,500	4,500	4,500	4,500	4,500	

Note:

- 1 usRT = 3,024kcal/h, 1kW = 860kcal/h
- Standard Tube and Water Side Pressure(Chiller & Cooling Water Circuit): 10kg/cm<sup>2</sup>G(981kPa)
- Currents & Electricity Consumptions are based on 3ø 380V 60Hz
- Alternate cooling water temperature range available upon request.
- Power supply wire size is based on the due of metal conduit and 40°C of ambient temperature.
- The specifications are subject to change without prior notice.
- For other than above this table, contact nearest LG Electronics office.

### WC2H Series(Chilled Water 12°C - 7°C COP 0.73, IPLV 0.91)

Model name		WC2H047	WC2H053	WC2H060	WC2H068	WC2H075	WC2H083
Cooling Capacity	USRT	470	530	600	680	750	830
	kW	1,654	1,865	2,111	2,393	2,639	2,920
Chilled Water Data	Temperature	°C 12 → 7					
	Water Flow Rate	m <sup>3</sup> /h 284.3	320.5	362.9	411.3	453.6	502.0
	Pressure Drop	mAq 5.3	7.3	6.9	9.6	12.5	3.9
	Connection Size	B(inch) 8	8	10	10	10	12
Cooling Water Data	Temperature	°C 32 → 37					
	Water Flow Rate	m <sup>3</sup> /h 673.6	759.6	860.0	974.6	1,075.0	1,189.6
	Pressure Drop	mAq 7.4	9.9	6.7	9.0	11.6	9.2
	Connection Size	B(inch) 10	10	12	12	12	14
Hot Water Data	Temperature	°C 95 → 55					
	Water Flow Rate	ton/h 48.7	54.9	62.1	70.4	77.7	86.0
	Pressure Drop	mAq 2.6	3.6	2.4	3.3	4.3	3.5
	Pressure Drop(Valve)	mAq 2.4	1.4	1.8	2.3	2.8	1.6
	Connection Size	B(inch) 4	4	5	5	5	5
	Connection Size(Valve)	DN 80	100	100	100	100	125
Electrical Data	Source	V 3ø 220/380/440V 50/60Hz					
	Total Current	A 24.4	37.6	40.8	40.8	40.8	36.9
	Wire Size	mm <sup>2</sup> 4	16	16	16	16	16
	Power	kVA 16.1	24.7	26.9	26.9	26.9	24.3
	Absorbent Pump(Main)	kW 6.5	9.7	9.7	9.7	9.7	7.4
		A 18.1	22.3	22.3	22.3	22.3	17.1
	Absorbent Pump(Sub)	kW 0.8	4.4	4.4	4.4	4.4	4.4
		A 3.2	12.2	12.2	12.2	12.2	12.2
	Refrigerant Pump	kW 0.4	0.4	1.5	1.5	1.5	2.2
		A 1.6	1.6	4.8	4.8	4.8	6.1
	Purge Pump	kW 0.4	0.4	0.4	0.4	0.4	0.4
A 1.0		1.0	1.0	1.0	1.0	1.0	
Dimension	Length	mm 5,500	6,000	5,680	6,180	6,700	6,270
	Width	mm 2,940	2,940	3,400	3,400	3,400	4,070
	Height	mm 3,370	3,370	3,725	3,725	3,725	3,890
Rigging	Operating	ton 24.8	27.0	33.6	36.0	39.2	43.2
	Max. Shipping	ton 18.9	20.4	25.0	26.9	29.1	32.4
	Total Shipping	ton 21.3	23.2	28.3	30.5	33.1	37.6
Clearance For Tube Removal	mm	5,200	5,700	5,200	5,700	6,200	5,700

Note:

- 1 usRT = 3,024kcal/h, 1kW = 860kcal/h
- Standard Tube and Water Side Pressure(Chiller & Cooling Water Circuit): 10kg/cm<sup>2</sup>G(981kPa)
- Currents & Electricity Consumptions are based on 3ø 380V 60Hz
- Alternate cooling water temperature range available upon request.
- Power supply wire size is based on the due of metal conduit and 40°C of ambient temperature.
- The specifications are subject to change without prior notice.
- For other than above this table, contact nearest LG Electronics office.

### WC2H Series(Chilled Water 12°C - 7°C COP 0.73, IPLV 0.91)

Model name		WC2H090	WC2H098	WC2H105	WC2H113	WC2H120	WC2H135
Cooling Capacity	USRT	900	980	1,050	1,130	1,200	1,350
	kW	3,167	3,448	3,694	3,976	4,222	4,750
Chilled Water Data	Temperature	°C 12 → 7					
	Water Flow Rate	m <sup>3</sup> /h 544.3	592.7	635.0	683.4	725.8	816.5
	Pressure Drop	mAq 4.9	6.1	5.4	6.6	7.9	10.6
	Connection Size	B(inch) 12	12	12	12	12	12
Cooling Water Data	Temperature	°C 32 → 37					
	Water Flow Rate	m <sup>3</sup> /h 1,290.0	1,404.6	1,505.0	1,619.6	1,720.0	1,934.9
	Pressure Drop	mAq 11.4	14.2	10.8	13.2	9.8	12.9
	Connection Size	B(inch) 14	14	16	16	16	16
Hot Water Data	Temperature	°C 95 → 55					
	Water Flow Rate	ton/h 93.2	101.5	108.7	117.0	124.3	139.8
	Pressure Drop	mAq 4.3	5.5	4.2	5.2	3.5	4.6
	Pressure Drop(Valve)	mAq 1.8	2.2	2.5	2.9	1.6	2.0
	Connection Size	B(inch) 5	5	6	6	6	6
	Connection Size(Valve)	DN 125	125	125	125	150	150
Electrical Data	Source	V 3ø 220/380/440V 50/60Hz					
	Total Current	A 36.9	36.9	42.0	42.0	42.0	42.0
	Wire Size	mm <sup>2</sup> 16	16	16	16	16	16
	Power	kVA 24.3	24.3	27.6	27.6	27.6	27.6
	Absorbent Pump(Main)	kW 7.4	7.4	10.7	10.7	10.7	10.7
		A 17.1	17.1	24.8	24.8	24.8	24.8
	Absorbent Pump(Sub)	kW 4.4	4.4	3.0	3.0	3.0	3.0
		A 12.2	12.2	9.6	9.6	9.6	9.6
	Refrigerant Pump	kW 2.2	2.2	2.2	2.2	2.2	2.2
		A 6.1	6.1	6.1	6.1	6.1	6.1
	Purge Pump	kW 0.4	0.4	0.4	0.4	0.4	0.4
A 1.0		1.0	1.0	1.0	1.0	1.0	
Dimension	Length	mm 6,795	7,295	6,820	7,320	7,840	8,320
	Width	mm 4,070	4,070	4,500	4,500	4,500	4,500
	Height	mm 3,890	3,890	4,080	4,080	4,080	4,080
Rigging	Operating	ton 47.2	51.2	55.2	59.8	64.8	67.6
	Max. Shipping	ton 35.8	37.9	40.0	42.1	46.0	49.7
	Total Shipping	ton 41.5	44.2	46.1	48.6	53.4	57.9
Clearance For Tube Removal	mm	6,200	6,700	6,200	6,700	7,400	8,000

Note:

- 1 usRT = 3,024kcal/h, 1kW = 860kcal/h
- Standard Tube and Water Side Pressure(Chiller & Cooling Water Circuit): 10kg/cm<sup>2</sup>G(981kPa)
- Currents & Electricity Consumptions are based on 3ø 380V 60Hz
- Alternate cooling water temperature range available upon request.
- Power supply wire size is based on the due of metal conduit and 40°C of ambient temperature.
- The specifications are subject to change without prior notice.
- For other than above this table, contact nearest LG Electronics office.



### WC2N Series(Chilled Water 12°C - 7°C COP 0.65, IPLV 0.84)

Model name		WC2N008	WC2N009	WC2N011	WC2N014	WC2N016	WC2N018	WC2N021	
Cooling Capacity	USRT	80	90	110	140	160	180	210	
	kW	281	317	387	493	563	633	739	
Chilled Water Data	Temperature	°C 12 → 7							
	Water Flow Rate	m <sup>3</sup> /h	48.4	54.4	66.5	84.7	96.8	108.9	127.0
	Pressure Drop	mAq	11.2	9.6	6.0	6.7	6.1	6.0	4.2
	Connection Size	B(inch)	3	3	4	4	5	5	5
Cooling Water Data	Temperature	°C 32 → 37							
	Water Flow Rate	m <sup>3</sup> /h	122.8	138.2	168.9	214.9	245.6	276.3	322.4
	Pressure Drop	mAq	13.4	12.5	12.4	14.3	8.2	8.4	14.6
	Connection Size	B(inch)	4	4	5	5	6	6	8
Hot Water Data	Temperature	°C 95 → 55							
	Water Flow Rate	ton/h	9.3	10.5	12.8	16.3	18.6	20.9	24.4
	Pressure Drop	mAq	5.1	4.4	5.7	6.0	5.7	5.6	5.8
	Pressure Drop(Valve)	mAq	1.4	1.8	2.6	2.7	2.2	2.7	2.4
	Connection Size	B(inch)	2	2	2 1/2	2 1/2	3	3	3
	Connection Size(Valve)	DN	40	40	40	50	50	50	65
Electrical Data	Source	V	3ø 220/380/440V 50/60Hz						
	Total Current	A	10.7	10.7	12.0	12.0	12.0	12.0	18.6
	Wire Size	mm <sup>2</sup>	4	4	4	4	4	4	4
	Power	kVA	7.0	7.0	7.9	7.9	7.9	7.9	12.2
	Absorbent Pump(Main)	kW	1.7	1.7	1.7	1.7	1.7	1.7	4.1
		A	5.9	5.9	5.9	5.9	5.9	5.9	12.0
	Absorbent Pump(Sub)	kW	0.4	0.4	1.0	1.0	1.0	1.0	1.0
		A	2.2	2.2	3.5	3.5	3.5	3.5	3.5
	Refrigerant Pump	kW	0.2	0.2	0.2	0.2	0.2	0.2	0.4
		A	1.1	1.1	1.1	1.1	1.1	1.1	1.6
Purge Pump	kW	0.4	0.4	0.4	0.4	0.4	0.4	0.4	
	A	1.0	1.0	1.0	1.0	1.0	1.0	1.0	
Dimension	Length	mm	2,790	2,790	3,810	3,810	3,850	3,850	4,840
	Width	mm	2,180	2,180	2,090	2,090	2,210	2,210	2,210
	Height	mm	2,310	2,310	2,310	2,310	2,675	2,675	2,675
Rigging	Operating	ton	5.6	5.8	7.0	7.4	9.4	9.8	11.2
	Max. Shipping	ton	4.4	4.5	5.4	5.5	7.0	7.2	8.4
	Total Shipping	ton	4.9	5.1	6.2	6.4	8.0	8.3	9.6
Clearance For Tube Removal	mm	2,400	2,400	3,400	3,400	3,400	3,400	4,500	

Note:

- 1 usRT = 3,024kcal/h, 1kW = 860kcal/h
- Standard Tube and Water Side Pressure(Chiller & Cooling Water Circuit): 10kg/cm<sup>2</sup>G(981kPa)
- Currents & Electricity Consumptions are based on 3ø 380V 60Hz
- Alternate cooling water temperature range available upon request.
- Power supply wire size is based on the due of metal conduit and 40°C of ambient temperature.
- The specifications are subject to change without prior notice.
- For other than above this table, contact nearest LG Electronics office.

### WC2N Series(Chilled Water 12°C - 7°C COP 0.65, IPLV 0.84)

Model name		WC2N024	WC2N027	WC2N030	WC2N034	WC2N038	WC2N042	
Cooling Capacity	USRT	240	270	300	340	380	420	
	kW	844	950	1,056	1,196	1,337	1,478	
Chilled Water Data	Temperature	°C 12 → 7						
	Water Flow Rate	m <sup>3</sup> /h	145.2	163.3	181.4	205.6	229.8	254.0
	Pressure Drop	mAq	4.3	4.2	4.3	4.1	4.0	3.9
	Connection Size	B(inch)	5	6	6	8	8	8
Cooling Water Data	Temperature	°C 32 → 37						
	Water Flow Rate	m <sup>3</sup> /h	368.5	414.5	460.6	522.0	583.4	644.8
	Pressure Drop	mAq	14.6	7.2	7.6	6.7	6.9	6.9
	Connection Size	B(inch)	8	8	8	10	10	10
Hot Water Data	Temperature	°C 95 → 55						
	Water Flow Rate	ton/h	27.9	31.4	34.9	39.5	44.2	48.8
	Pressure Drop	mAq	5.8	5.3	5.3	5.4	5.4	3.1
	Pressure Drop(Valve)	mAq	2.0	2.5	1.9	2.4	2.0	2.4
	Connection Size	B(inch)	3	4	4	4	4	4
	Connection Size(Valve)	DN	65	65	80	80	80	80
Electrical Data	Source	V	3ø 220/380/440V 50/60Hz					
	Total Current	A	18.6	18.6	18.6	24.4	24.4	24.4
	Wire Size	mm <sup>2</sup>	4	4	4	4	4	4
	Power	kVA	12.2	12.2	12.2	16.1	16.1	16.1
	Absorbent Pump(Main)	kW	4.1	4.1	4.1	6.5	6.5	6.5
		A	12.0	12.0	12.0	18.1	18.1	18.1
	Absorbent Pump(Sub)	kW	1.0	1.0	1.0	0.8	0.8	0.8
		A	3.5	3.5	3.5	3.2	3.2	3.2
	Refrigerant Pump	kW	0.4	0.4	0.4	0.4	0.4	0.4
		A	1.6	1.6	1.6	1.6	1.6	1.6
Purge Pump	kW	0.4	0.4	0.4	0.4	0.4	0.4	
	A	1.0	1.0	1.0	1.0	1.0	1.0	
Dimension	Length	mm	4,840	4,840	4,840	4,930	4,930	4,955
	Width	mm	2,210	2,500	2,500	2,710	2,710	2,940
	Height	mm	2,675	2,770	2,770	3,120	3,120	3,370
Rigging	Operating	ton	11.8	14.2	14.8	18.4	19.2	22.8
	Max. Shipping	ton	8.6	10.7	10.9	13.8	14.2	16.9
	Total Shipping	ton	9.9	12.1	12.4	15.6	16.1	19.0
Clearance For Tube Removal	mm	4,500	4,500	4,500	4,500	4,500	4,500	

Note:

- 1 usRT = 3,024kcal/h, 1kW = 860kcal/h
- Standard Tube and Water Side Pressure(Chiller & Cooling Water Circuit): 10kg/cm<sup>2</sup>G(981kPa)
- Currents & Electricity Consumptions are based on 3ø 380V 60Hz
- Alternate cooling water temperature range available upon request.
- Power supply wire size is based on the due of metal conduit and 40°C of ambient temperature.
- The specifications are subject to change without prior notice.
- For other than above this table, contact nearest LG Electronics office.

### WC2N Series(Chilled Water 12°C - 7°C COP 0.65, IPLV 0.84)

Model name		WC2N047	WC2N053	WC2N060	WC2N068	WC2N075	WC2N083	
Cooling Capacity	USRT	470	530	600	680	750	830	
	kW	1,654	1,865	2,111	2,393	2,639	2,920	
Chilled Water Data	Temperature	°C 12 → 7						
	Water Flow Rate	m <sup>3</sup> /h	284.3	320.5	362.9	411.3	453.6	502.0
	Pressure Drop	mAq	5.3	7.3	6.9	9.6	12.5	3.9
	Connection Size	B(inch)	8	8	10	10	10	12
Cooling Water Data	Temperature	°C 32 → 37						
	Water Flow Rate	m <sup>3</sup> /h	721.6	813.7	921.2	1,044.0	1,151.4	1,274.3
	Pressure Drop	mAq	9.2	12.3	8.4	11.4	14.7	11.6
	Connection Size	B(inch)	10	10	12	12	12	14
Hot Water Data	Temperature	°C 95 → 55						
	Water Flow Rate	ton/h	54.7	61.6	69.8	79.1	87.2	96.5
	Pressure Drop	mAq	4.3	6.0	4.0	5.6	5.9	5.9
	Pressure Drop(Valve)	mAq	3.0	1.7	2.2	2.8	1.6	1.9
	Connection Size	B(inch)	4	4	5	5	5	5
	Connection Size(Valve)	DN	80	100	100	100	125	125
Electrical Data	Source	V	3ø 220/380/440V 50/60Hz					
	Total Current	A	24.4	37.6	40.8	40.8	40.8	36.9
	Wire Size	mm <sup>2</sup>	4	16	16	16	16	16
	Power	kVA	16.1	24.7	26.9	26.9	26.9	24.3
	Absorbent Pump(Main)	kW	6.5	9.7	9.7	9.7	9.7	7.4
		A	18.1	22.3	22.3	22.3	22.3	17.1
	Absorbent Pump(Sub)	kW	0.8	4.4	4.4	4.4	4.4	4.4
		A	3.2	12.2	12.2	12.2	12.2	12.2
	Refrigerant Pump	kW	0.4	0.4	1.5	1.5	1.5	2.2
		A	1.6	1.6	4.8	4.8	4.8	6.1
	Purge Pump	kW	0.4	0.4	0.4	0.4	0.4	0.4
A		1.0	1.0	1.0	1.0	1.0	1.0	
Dimension	Length	mm	5,500	6,000	5,680	6,180	6,700	6,270
	Width	mm	2,940	2,940	3,400	3,400	3,400	4,070
	Height	mm	3,370	3,370	3,725	3,725	3,725	3,890
Rigging	Operating	ton	24.8	27.0	33.6	36.0	39.2	43.2
	Max. Shipping	ton	18.2	19.6	24.1	25.9	28.1	32.2
	Total Shipping	ton	20.6	22.5	27.4	29.6	32.1	37.4
Clearance For Tube Removal	mm	5,200	5,700	5,200	5,700	6,200	5,700	

Note:

- 1 usRT = 3,024kcal/h, 1kW = 860kcal/h
- Standard Tube and Water Side Pressure(Chiller & Cooling Water Circuit): 10kg/cm<sup>2</sup>G(981kPa)
- Currents & Electricity Consumptions are based on 3ø 380V 60Hz
- Alternate cooling water temperature range available upon request.
- Power supply wire size is based on the due of metal conduit and 40°C of ambient temperature.
- The specifications are subject to change without prior notice.
- For other than above this table, contact nearest LG Electronics office.

### WC2N Series(Chilled Water 12°C - 7°C COP 0.65, IPLV 0.84)

Model name		WC2N090	WC2N098	WC2N105	WC2N113	WC2N120	WC2N135	
Cooling Capacity	USRT	900	980	1,050	1,130	1,200	1,350	
	kW	3,167	3,448	3,694	3,976	4,222	4,750	
Chilled Water Data	Temperature	°C 12 → 7						
	Water Flow Rate	m <sup>3</sup> /h	544.3	592.7	635.0	683.4	725.8	816.5
	Pressure Drop	mAq	4.9	6.1	5.4	6.6	7.9	10.6
	Connection Size	B(inch)	12	12	12	12	12	12
Cooling Water Data	Temperature	°C 32 → 37						
	Water Flow Rate	m <sup>3</sup> /h	1,381.7	1,504.6	1,612.0	1,734.8	1,842.3	2,072.6
	Pressure Drop	mAq	14.4	18.0	13.7	16.7	13.2	17.5
	Connection Size	B(inch)	14	14	16	16	16	16
Hot Water Data	Temperature	°C 95 → 55						
	Water Flow Rate	ton/h	104.7	114.0	122.1	131.4	139.6	157.0
	Pressure Drop	mAq	6.0	6.0	5.9	5.9	5.5	5.9
	Pressure Drop(Valve)	mAq	2.3	2.7	1.5	1.7	2.0	2.5
	Connection Size	B(inch)	5	5	6	6	6	6
	Connection Size(Valve)	DN	125	125	150	150	150	150
Electrical Data	Source	V	3ø 220/380/440V 50/60Hz					
	Total Current	A	36.9	36.9	42.0	42.0	42.0	42.0
	Wire Size	mm <sup>2</sup>	16	16	16	16	16	16
	Power	kVA	24.3	24.3	27.6	27.6	27.6	27.6
	Absorbent Pump(Main)	kW	7.4	7.4	10.7	10.7	10.7	10.7
		A	17.1	17.1	24.8	24.8	24.8	24.8
	Absorbent Pump(Sub)	kW	4.4	4.4	3.0	3.0	3.0	3.0
		A	12.2	12.2	9.6	9.6	9.6	9.6
	Refrigerant Pump	kW	2.2	2.2	2.2	2.2	2.2	2.2
		A	6.1	6.1	6.1	6.1	6.1	6.1
	Purge Pump	kW	0.4	0.4	0.4	0.4	0.4	0.4
A		1.0	1.0	1.0	1.0	1.0	1.0	
Dimension	Length	mm	6,795	7,295	6,820	7,320	7,840	8,320
	Width	mm	4,070	4,070	4,500	4,500	4,500	4,500
	Height	mm	3,890	3,890	4,080	4,080	4,080	4,080
Rigging	Operating	ton	47.2	51.2	55.2	59.8	64.8	67.6
	Max. Shipping	ton	34.5	36.5	39.8	41.8	45.6	49.2
	Total Shipping	ton	40.2	42.8	45.9	48.4	53.0	57.4
Clearance For Tube Removal	mm	6,200	6,700	6,200	6,700	7,400	8,000	

Note:

- 1 usRT = 3,024kcal/h, 1kW = 860kcal/h
- Standard Tube and Water Side Pressure(Chiller & Cooling Water Circuit): 10kg/cm<sup>2</sup>G(981kPa)
- Currents & Electricity Consumptions are based on 3ø 380V 60Hz
- Alternate cooling water temperature range available upon request.
- Power supply wire size is based on the due of metal conduit and 40°C of ambient temperature.
- The specifications are subject to change without prior notice.
- For other than above this table, contact nearest LG Electronics office.

Heat Pump	Energy	Available	Model Selection			(Example) Application
			Efficiency	Model	Remark	
Waste Heating Source	Gas Steam Hot Water	COP 1.65-1.80	WCPX	World Class High Efficiency Hot Water Temp. : 55-90°C	Combined Heat and Power Incinerator System	

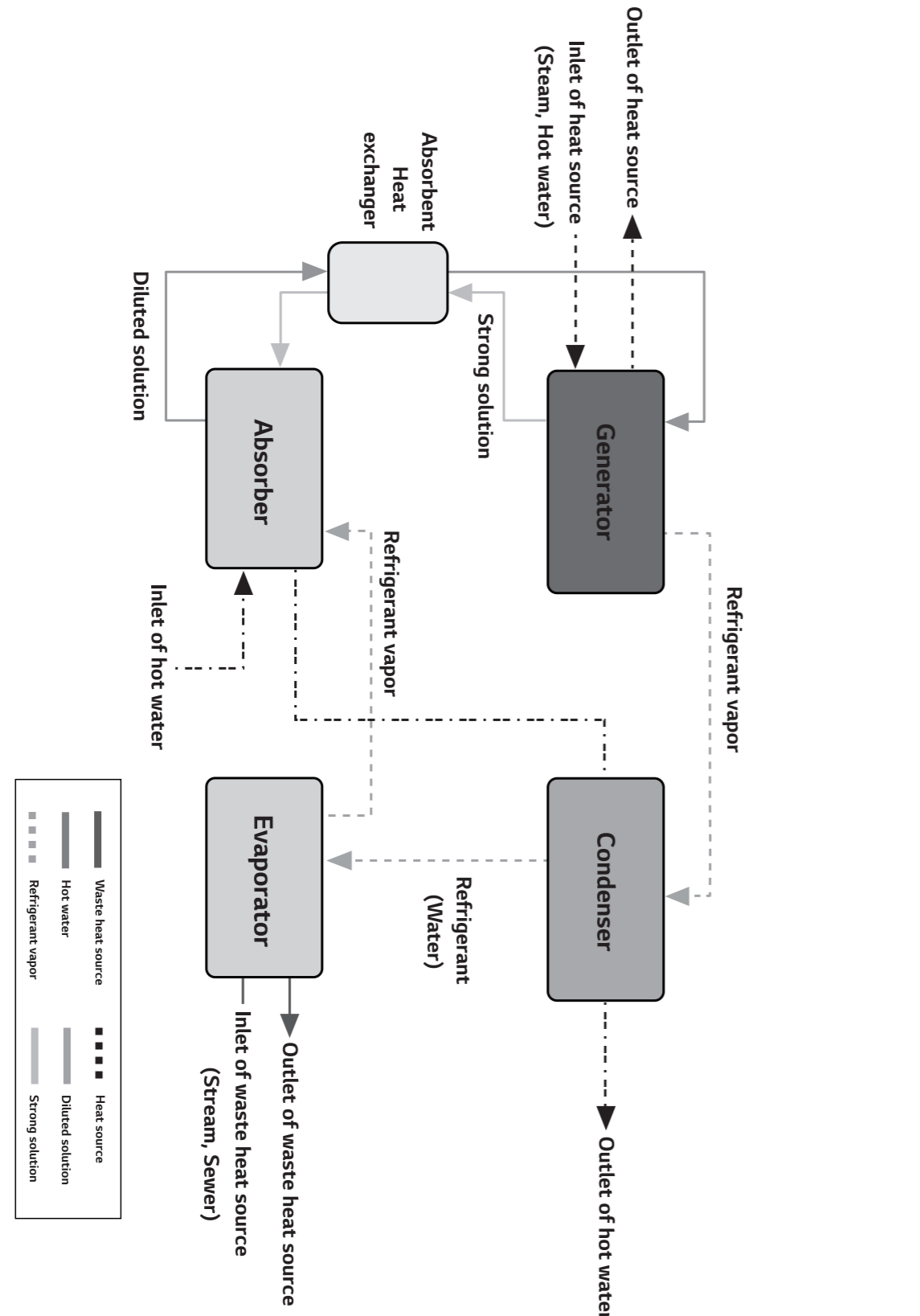

### WCPX First absorption Heat pump(Steam 0.8 MPa)

Model name		WCPX003	WCPX007	WCPX010	WCPX015	WCPX020	
Waste Heat Source Capacity	10 <sup>4</sup> kcal/h	13	31	44	67	89	
	kW	349	814	1,162	1,743	2,324	
Hot Water Capacity	10 <sup>4</sup> kcal/h	30	70	100	150	200	
	Temperature	°C 55.0 → 90.0					
Hot Water Data	Water Flow Rate	m <sup>3</sup> /h	8.7	20.3	29.0	43.5	58.0
	Pressure Drop	mAq	5.8	10.0	7.4	10.1	8.5
	Connection Size	mm(A)	40	65	65	65	80
		inch(B)	1 1/2	2 1/2	2 1/2	2 1/2	3
Waste Heat Source System	Temperature	°C 46.0 → 40.0					
	Water Flow Rate	m <sup>3</sup> /h	22.5	52.5	74.9	112.4	149.9
	Pressure Drop	mAq	5.0	4.4	4.4	4.5	4.4
	Connection Size	mm(A)	65	100	100	100	125
inch(B)		2 1/2	4	4	4	5	
Steam Data	Steam Flow Rate	kg/h	316	738	1,055	1,582	2,110
	Steam Inlet Connection	mm(A)	40	50	65	65	80
		inch(B)	1 1/2	2	2 1/2	2 1/2	3
	Drain Outlet Connection	mm(A)	25	25	25	32	40
		inch(B)	1	1	1	1 1/4	1 1/2
Steam Control Valve	mm(A)	40	40	40	50	65	
	inch(B)	1 1/2	1 1/2	1 1/2	2	2 1/2	
Electrical Data	Source	V 3ø 220/380/440V 50/60Hz					
	Total Current	A	7.6	8.9	8.9	9.9	9.9
	Wire Size	mm <sup>2</sup>	3.5	3.5	3.5	3.5	3.5
	Power	kVA	5.0	5.9	5.9	6.5	6.5
	Absorbent Pump No.1	kW(A)	1.2(4.1)	1.5(5.4)	1.5(5.4)	2.4(6.4)	2.4(6.4)
	Refrigerant Pump	kW(A)	0.2(1.1)	0.2(1.1)	0.2(1.1)	0.2(1.1)	0.2(1.1)
Dimension	Purge Pump	kW(A)	0.4(1.6)	0.4(1.6)	0.4(1.6)	0.4(1.6)	0.4(1.6)
	Length	mm	2,180	2,680	2,680	3,700	3,760
	Width	mm	1,400	1,460	1,460	1,460	1,630
Rigging	Height	mm	2,090	2,210	2,210	2,350	2,600
	Operating	ton	3.0	4.6	4.9	6.5	8.4
	Total Shipping	ton	2.8	4.2	4.4	5.8	7.5
Max Shipping	ton	2.4	3.6	3.7	4.7	6.1	

- Note:
- 1kW = 860kcal/h
  - Standard Fouling factor of Waste heat source & Hot Water Circuit : 0.086m<sup>2</sup>K/kW(0.0001m<sup>2</sup>.h.°C)
  - Standard Tube and Water Side Pressure(Waste heat source & Hot Water Circuit): 10kg/cm<sup>2</sup>G(981kPa)
  - Max. steam pressure : 785kPa = 8kg/cm<sup>2</sup>G
  - Currents & Electricity Consumptions are based on 3ø 380V 60Hz
  - Power supply wire size is based on the due of metal conduit and 40°C of ambient temperature.
  - Total Shipping Weight include weight of the burner & liquid.
  - The specifications are subject to change without prior notice.
  - For other than above this table, contact nearest LG Electronics office.

### WCPX First absorption Heat pump(Steam 0.8 MPa)

Model name		WCPX026	WCPX033	WCPX040	WCPX052	WCPX066	
Waste Heat Source Capacity		10 <sup>4</sup> kcal/h	116	147	178	231	293
Hot water Capacity		kW	3,022	3,835	4,649	6,044	7,671
		10 <sup>4</sup> kcal/h	260	330	400	520	660
Hot Water Data	Temperature	°C	55.0 → 90.0				
	Water Flow Rate	m <sup>3</sup> /h	75.4	95.7	116.0	150.8	191.4
	Pressure Drop	mAq	12.8	11.0	9.8	10.0	7.5
	Connection Size	mm(A)	100	100	125	125	150
		inch(B)	4	4	5	5	6
Waste Heat Source System	Temperature	°C	46.0 → 40.0				
	Water Flow Rate	m <sup>3</sup> /h	194.9	247.3	299.8	389.7	494.6
	Pressure Drop	mAq	8.6	8.8	8.4	11.3	6.0
	Connection Size	mm(A)	150	150	200	200	250
		inch(B)	6	6	8	8	10
Steam Data	Steam Flow Rate	kg/h	2,742	3,481	4,219	5,485	6,962
	Steam Inlet Connection	mm(A)	100	100	125	150	200
		inch(B)	4	4	5	6	8
	Drain outlet Connection	mm(A)	50	65	65	80	80
		inch(B)	2	2 1/2	2 1/2	3	3
	Steam Control Valve	mm(A)	65	80	80	100	150
inch(B)		2 1/2	3	3	4	6	
Electrical Data	Source	V	3ø 220/380/440V 50/60Hz				
	Total Current	A	14.3	14.3	16.0	20.2	20.1
	Wire Size	mm <sup>2</sup>	3.5	3.5	3.5	5.5	5.5
	Power	kVA	9.4	9.4	10.5	13.3	13.2
	Absorbent Pump No.1	kW(A)	3.4(10.3)	3.4(10.3)	3.7(12.0)	6.6(16.2)	6.6(16.2)
	Refrigerant Pump	kW(A)	0.4(1.4)	0.4(1.4)	0.4(1.4)	0.4(1.4)	0.4(1.4)
	Purge Pump	kW(A)	0.4(1.6)	0.4(1.6)	0.4(1.6)	0.4(1.6)	0.4(1.6)
Dimension	Length	mm	4,780	4,880	4,880	5,630	5,740
	Width	mm	1,630	1,680	1,810	2,120	2,300
	Height	mm	2,600	2,960	3,270	3,800	4,000
Rigging	Operating	ton	10.4	13.1	16.0	23.8	30.6
	Total Shipping	ton	9.2	11.6	14.1	20.9	26.5
	Max Shipping	ton	7.4	9.4	11.5	17.3	22.0

Note:

- 1kW = 860kcal/h
- Standard Fouling factor of Waste heat source & Hot Water Circuit : 0.086m<sup>2</sup>K/kW(0.0001m<sup>2</sup>.h.°C)
- Standard Tube and Water Side Pressure(Waste heat source & Hot Water Circuit): 10kg/cm<sup>2</sup>G(981kPa)
- Max. steam pressure : 785kPa = 8kg/cm<sup>2</sup>G
- Currents & Electricity Consumptions are based on 3ø 380V 60Hz
- Power supply wire size is based on the due of metal conduit and 40°C of ambient temperature.
- Total Shipping Weight include weight of the burner & liquid.
- The specifications are subject to change without prior notice.
- For other than above this table, contact nearest LG Electronics office.

### WCPX First absorption Heat pump(Steam 0.8 MPa)

Model name		WCPX082	WCPX098	WCPX115	WCPX130	WCPX147	
Waste Heat Source Capacity		10 <sup>4</sup> kcal/h	364	436	511	578	653
Hot water Capacity		kW	9,530	11,390	13,366	15,109	17,085
		10 <sup>4</sup> kcal/h	820	980	1,150	1,300	1,470
Hot Water Data	Temperature	°C	55.0 → 90.0				
	Water Flow Rate	m <sup>3</sup> /h	237.8	284.2	333.5	377.0	426.3
	Pressure Drop	mAq	12.4	16.5	19.5	12.6	16.7
	Connection Size	mm(A)	150	200	200	250	250
		inch(B)	6	8	8	10	10
Waste heat Source System	Temperature	°C	46.0 → 40.0				
	Water Flow Rate	m <sup>3</sup> /h	614.5	734.4	861.9	974.3	1,101.7
	Pressure Drop	mAq	10.7	10.3	10.5	2.3	3.1
	Connection Size	mm(A)	250	300	350	400	400
		inch(B)	10	12	14	16	16
Steam Data	Steam Flow Rate	kg/h	8,649	10,337	12,130	13,712	15,505
	Steam Inlet Connection	mm(A)	200	200	250	250	250
		inch(B)	8	8	10	10	10
	Drain Outlet Connection	mm(A)	80	100	100	125	125
		inch(B)	3	4	4	5	5
	Steam Control Valve	mm(A)	150	150	200	200	200
inch(B)		6	6	8	8	8	
Electrical data	Source	V	3ø 220/380/440V 50/60Hz				
	Total Current	A	30.0	32.6	32.6	45.6	45.6
	Wire Size	mm <sup>2</sup>	8	8	8	14	14
	Power	kVA	19.7	21.5	21.5	30	30
	Absorbent Pump No.1	kW(A)	7.5(25.0)	7.5(25.0)	7.5(25.0)	15(36.0)	15(36.0)
	Refrigerant Pump	kW(A)	0.4(1.4)	1.5(4.0)	1.5(4.0)	3(5.8)	3(5.8)
	Purge Pump	kW(A)	0.75(2.5)	0.75(2.5)	0.75(2.5)	0.75(2.5)	0.75(2.5)
Dimension	Length	mm	6,760	6,720	6,860	7,370	8,170
	Width	mm	2,300	2,780	3,010	3,240	3,240
	Height	mm	4,000	4,200	4,300	4,400	4,400
Rigging	Operating	ton	35.1	41.3	48.2	55.8	59.3
	Total Shipping	ton	30.5	36.5	42.7	49.5	52.3
	Max Shipping	ton	25.1	29.4	34.2	40.2	42.0

Note:

- 1kW = 860kcal/h
- Standard Fouling factor of Waste heat source & Hot Water Circuit : 0.086m<sup>2</sup>K/kW(0.0001m<sup>2</sup>.h.°C)
- Standard Tube and Water Side Pressure(Waste heat source & Hot Water Circuit): 10kg/cm<sup>2</sup>G(981kPa)
- Max. steam pressure : 785kPa = 8kg/cm<sup>2</sup>G
- Currents & Electricity Consumptions are based on 3ø 380V 60Hz
- Power supply wire size is based on the due of metal conduit and 40°C of ambient temperature.
- Total Shipping Weight include weight of the burner & liquid.
- The specifications are subject to change without prior notice.
- For other than above this table, contact nearest LG Electronics office.

### WCPX First absorption Heat pump(Steam 0.8 MPa)

Model name		WCPX163	WCPX196	WCPX230	WCPX260	
Waste Heat Source Capacity		10 <sup>4</sup> kcal/h	724	871	1,022	1,156
Hot Water Capacity		kW	18,944	22,780	26,731	30,218
		10 <sup>4</sup> kcal/h	1,630	1,960	2,300	2,600
Hot Water Data	Temperature	°C	55.0 → 90.0			
	Water Flow Rate	m <sup>3</sup> /h	472.7	568.4	667.0	754.0
	Pressure Drop	mAq	21.3	19.8	23.4	15.1
	Connection Size	mm(A)	250	300	350	350
		inch(B)	10	12	14	14
Waste Heat Source System	Temperature	°C	46.0 → 40.0			
	Water Flow Rate	m <sup>3</sup> /h	1,221.6	1,468.9	1,723.7	1,948.5
	Pressure Drop	mAq	4.1	12.4	12.6	3.2
	Connection Size	mm(A)	400	400	450	500
		inch(B)	16	16	18	20
Steam Data	Steam Flow Rate	kg/h	17,193	20,674	24,260	27,424
	Steam Inlet Connection	mm(A)	250	200 x 2	250 x 2	250 x 2
		inch(B)	10	8 x 2	10 x 2	10 x 2
	Drain Outlet Connection	mm(A)	125	100 x 2	100 x 2	125 x 2
		inch(B)	5	4 x 2	4 x 2	5 x 2
	Steam Control Valve	mm(A)	200	150 x 2	200 x 2	200 x 2
inch(B)		8	6 x 2	8 x 2	8 x 2	
Electrical Data	Source	V	3ø 220/380/440V 50/60Hz			
	Total Current	A	45.6	64.1	64.1	91.2
	Wire Size	mm <sup>2</sup>	14	30	30	50
	Power	kVA	30.0	42.2	42.2	60
	Absorbent Pump No.1	kW(A)	15(36.0)	7.5(25.0) x 2	7.5(25.0) x 2	15(36.0) x 2
	Refrigerant Pump	kW(A)	3(5.8)	1.5(4.0) x 2	1.5(4.0) x 2	3(5.8) x 2
	Purge Pump	kW(A)	0.75(2.5)	0.75(2.5) x 2	0.75(2.5) x 2	0.75(2.5) x 2
Dimension	Length	mm	8,970	6,720	6,860	7,370
	Width	mm	3,240	5,460	5,920	6,380
	Height	mm	4,400	4,300	4,400	4,400
Rigging	Operating	ton	62.9	82.6	96.5	112
	Total Shipping	ton	55.0	73.0	85.4	99.0
	Max Shipping	ton	43.7	29.4	34.2	40.2

- Note:
- 1kW = 860kcal/h
  - Standard Fouling factor of Waste heat source & Hot Water Circuit : 0.086m<sup>2</sup>K/kW(0.0001m<sup>2</sup>h.°C)
  - Standard Tube and Water Side Pressure(Waste heat source & Hot Water Circuit): 10kg/cm<sup>2</sup>G(981kPa)
  - Max. steam pressure : 785kPa = 8kg/cm<sup>2</sup>G
  - Currents & Electricity Consumptions are based on 3ø 380V 60Hz
  - Power supply wire size is based on the due of metal conduit and 40°C of ambient temperature.
  - Total Shipping Weight include weight of the burner & liquid.
  - The specifications are subject to change without prior notice.
  - For other than above this table, contact nearest LG Electronics office.

### WCPX First absorption Heat pump(Direct Fired)

Model name		WCPX003	WCPX007	WCPX010	WCPX015	WCPX020	WCPX026	
Waste Heat Source Capacity		10 <sup>4</sup> kcal/h	13	31	44	67	89	116
Hot water Capacity		kW	349	814	1,162	1,743	2,324	3,022
		10 <sup>4</sup> kcal/h	30	70	100	150	200	260
Hot Water Data	Temperature	°C	55.0 → 90.0					
	Water Flow Rate	m <sup>3</sup> /h	8.7	20.3	29.0	43.5	58.0	75.4
	Pressure Drop	mAq	5.8	10.0	7.4	10.1	8.5	12.8
	Connection Size	mm(A)	40	65	65	65	80	100
		inch(B)	1 1/2	2 1/2	2 1/2	2 1/2	3	4
Waste Heat Source System	Temperature	°C	46.0 → 40.0					
	Water Flow Rate	m <sup>3</sup> /h	22.5	52.5	74.9	112.4	149.9	194.9
	Pressure Drop	mAq	5.0	4.4	4.4	4.5	4.4	8.6
	Connection Size	mm(A)	65	100	100	100	125	150
		inch(B)	2 1/2	4	4	4	5	6
Fuel Consumption		Nm <sup>3</sup> /h	16.0	37.4	53.4	80.1	106.8	138.9
Electrical Data	Source	V	3ø 220/380/440V 50/60Hz					
	Total Current	A	9.8	11.1	13.5	14.8	21.7	26.1
	Wire Size	mm <sup>2</sup>	3.5	3.5	3.5	3.5	5.5	8.0
	Power	kVA	6.5	7.3	8.9	9.7	14.3	17.2
	Absorbent Pump No.1	kW(A)	1.2(4.1)	1.5(5.4)	1.5(5.4)	2.4(6.4)	2.4(6.4)	3.4(10.3)
	Refrigerant Pump	kW(A)	0.2(1.1)	0.2(1.1)	0.2(1.1)	0.2(1.1)	0.2(1.1)	0.4(1.4)
	Purge Pump	kW(A)	0.4(1.6)	0.4(1.6)	0.4(1.6)	0.4(1.6)	0.4(1.6)	0.4(1.6)
Dimension	Length	mm	2,620	3,120	3,120	3,990	4,020	4,820
	Width	mm	2,140	2,190	2,190	2,190	2,540	2,560
	Height	mm	2,030	2,060	2,060	2,120	2,390	2,610
Rigging	Operating	ton	4.5	5.6	6.0	7.9	10.1	12.8
	Total Shipping	ton	4.3	5.2	5.5	7.2	9.1	11.6
	Max Shipping	ton	3.6	4.3	4.4	5.7	7.3	9.3

- Note:
- 1kW = 860kcal/h
  - Standard Fouling factor of Waste heat source & Hot Water Circuit : 0.086m<sup>2</sup>K/kW(0.0001m<sup>2</sup>h.°C)
  - Standard Tube and Water Side Pressure(Waste heat source & Hot Water Circuit): 10kg/cm<sup>2</sup>G(981kPa)
  - Standard low calorific power : 9,360 kcal/Ncm<sup>2</sup>
  - Currents & Electricity Consumptions are based on 3ø 380V 60Hz
  - Power supply wire size is based on the due of metal conduit and 40°C of ambient temperature.
  - Total Shipping Weight include weight of the burner & liquid.
  - The specifications are subject to change without prior notice.
  - For other than above this table, contact nearest LG Electronics office.

### WCPX First absorption Heat pump(Direct Fired)

Model name		WCPX033	WCPX040	WCPX052	WCPX066	WCPX082	
Waste Heat Source Capacity	10 <sup>4</sup> kcal/h	147	178	231	293	364	
	kW	3,835	4,649	6,044	7,671	9,530	
Hot Water Capacity	10 <sup>4</sup> kcal/h	330	400	520	660	820	
	Temperature	55.0 → 90.0					
Hot Water Data	Water Flow Rate	95.7	116.0	150.8	191.4	237.8	
	Pressure Drop	11.0	9.8	10.0	7.5	12.4	
	Connection Size	mm(A)	100	125	125	150	150
		inch(B)	4	5	5	6	6
Waste Heat Source System	Temperature	46.0 → 40.0					
	Water Flow Rate	247.3	299.8	389.7	494.6	614.5	
	Pressure Drop	8.8	8.4	11.3	6.0	10.7	
	Connection Size	mm(A)	150	200	200	250	250
inch(B)		6	8	8	10	10	
Fuel Consumption	Nm <sup>3</sup> /h	176.3	213.7	277.8	352.6	438.0	
Electrical Data	Source	V 3ø 220/380/440V 50/60Hz					
	Total Current	A	30.3	32.0	36.2	42.9	59.3
	Wire Size	mm <sup>2</sup>	8.0	8.0	14.0	14.0	22.0
	Power	kVA	19.9	21.1	23.8	28.2	39.0
	Absorbent Pump No.1	kW(A)	3.4(10.3)	3.7(12.0)	6.6(16.2)	6.6(16.2)	7.5(25.0)
	Refrigerant Pump	kW(A)	0.4(1.4)	0.4(1.4)	0.4(1.4)	0.4(1.4)	0.4(1.4)
	Purge Pump	kW(A)	0.4(1.6)	0.4(1.6)	0.4(1.6)	0.4(1.6)	0.75(2.5)
Dimension	Burner	kW(A)	7.5(16.0)	7.5(16.0)	7.5(16.0)	11.0(22.7)	15.0(29.3)
	Length	mm	4,940	5,080	6,080	6,710	7,810
	Width	mm	2,830	3,010	3,500	4,020	4,070
Rigging	Height	mm	3,030	3,030	3,650	3,650	3,680
	Operating	ton	16.3	19.9	29.8	39.3	55.9
Total Shipping	ton	14.8	18.0	26.9	35.3	51.4	
	Max Shipping	ton	11.9	14.5	21.9	28.7	42.8

- Note:
1. 1kW = 860kcal/h
  2. Standard Fouling factor of Waste heat source & Hot Water Circuit : 0.086m<sup>2</sup>K/kW(0.0001m<sup>2</sup>h.°C)
  3. Standard Tube and Water Side Pressure(Waste heat source & Hot Water Circuit): 10kg/cm<sup>2</sup>G(981kPa)
  4. Standard low calorific power : 9,360 kcal/Ncm<sup>2</sup>
  5. Currents & Electricity Consumptions are based on 3ø 380V 60Hz
  6. Power supply wire size is based on the due of metal conduit and 40°C of ambient temperature.
  7. Total Shipping Weight include weight of the burner & liquid.
  8. The specifications are subject to change without prior notice.
  9. For other than above this table, contact nearest LG Electronics office.

Energy	Available	Model Selection			(Example) Application
		Efficiency	Model	Remark	
Chiller	Multiple Energy Exhaust Gas + Hot Water + (LNG)	COP 1.2	WCHA	Hybrid Absorption Chiller Using more than 2 kinds of heat source	Combined Heat and Power District energy system

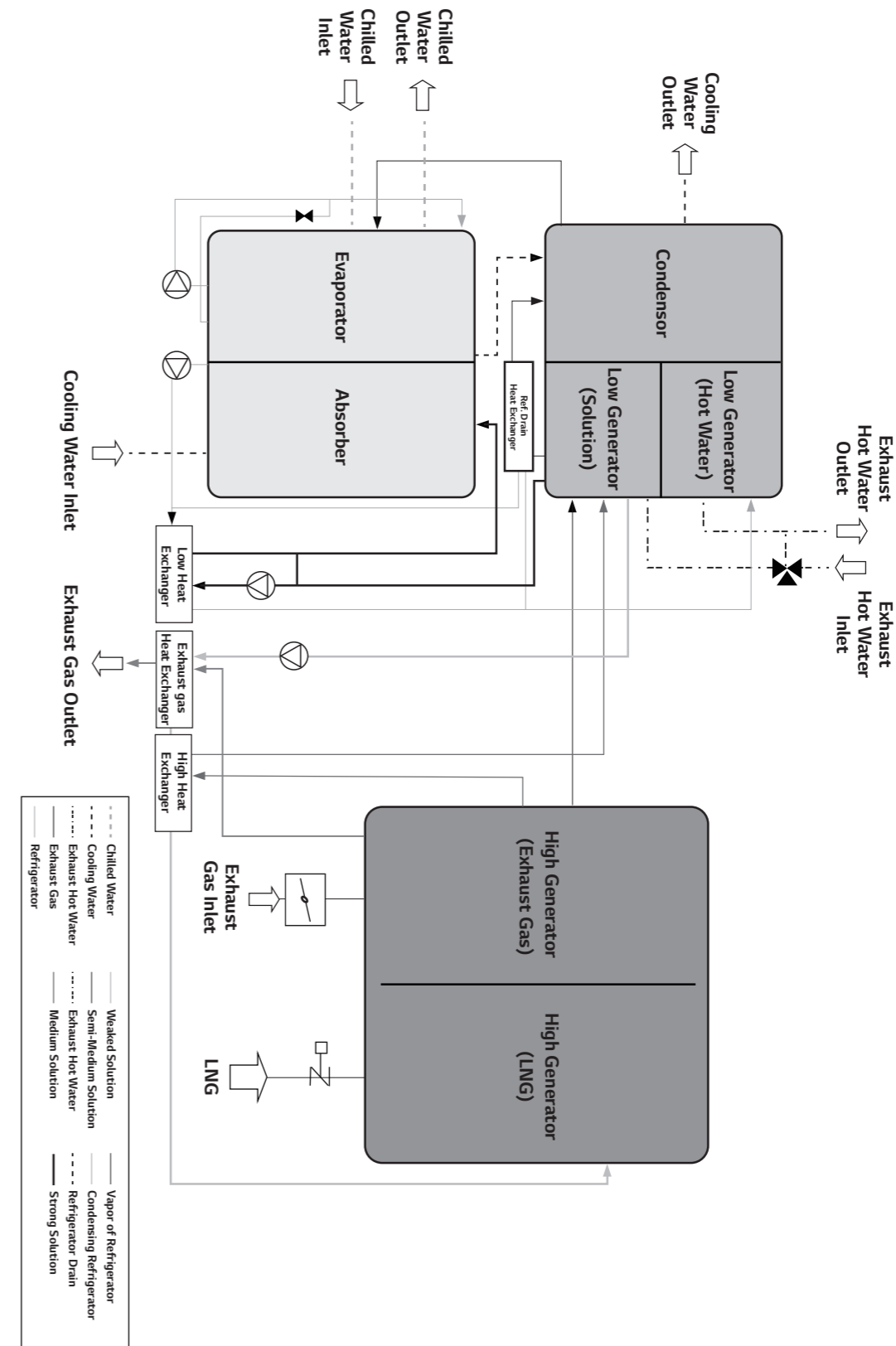

## Direct Fired(WCD Series, H,N)

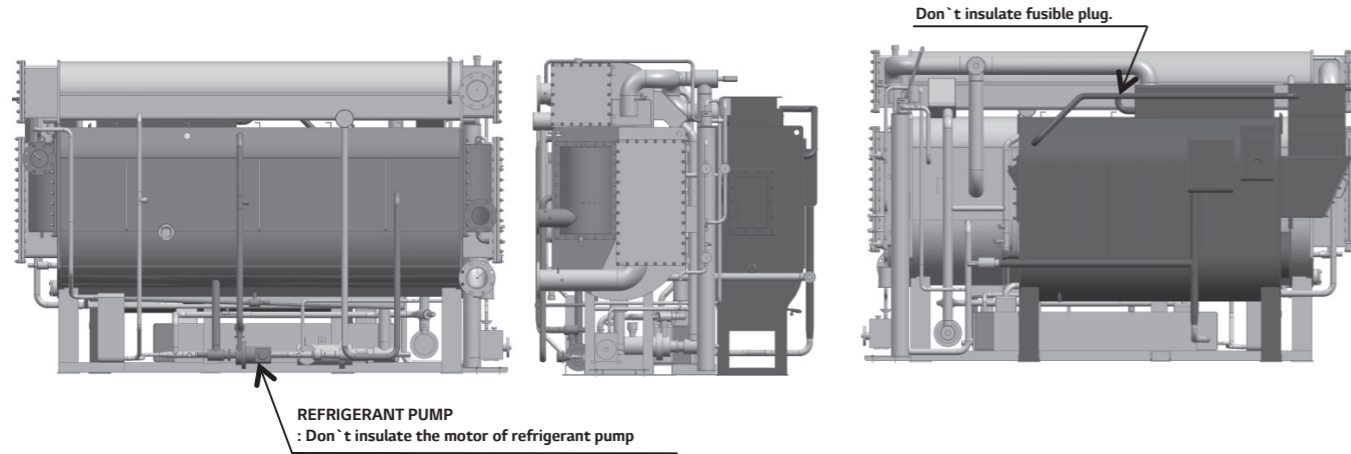

- 75mm FOR WARM SURFACE
- 25mm FOR WARM SURFACE
- 19mm FOR COLD SURFACE
- REMOVAL PART

**NOTE.**  
 • Material : Glass Wool, Galvanized Steel Plate, Nitrile-Butadiene Rubber(NBR)  
 1. Use noncombustible insulation material.  
 2. Do not insulate motor of refrigerant pump.  
 3. Insulation area includes piping.  
 4. The Chiller is coated with a anticorrosive paint at the factory.  
 Finish painting is typically performed in the field after insulating is complete.

Capacity(RT)	Hot Surface(m <sup>2</sup> )		Cold(m <sup>2</sup> )
	75mm	25mm	19mm
100	6.3	5.0	4.4
120	6.9	5.3	4.4
150	8.1	6.1	5.9
180	8.7	6.5	5.9
210	10.1	7.1	6.8
240	10.9	7.2	6.8
280	11.9	8.8	8.4
320	12.6	9.0	8.4
360	14.5	9.9	9.9
400	15.3	10.0	9.9
450	17.5	10.5	11.2
500	18.4	10.7	11.2
560	20.0	11.8	13.9
630	21.3	12.6	15
700	22.4	13.3	16.1
800	27.2	14.7	17.3
900	29.0	15.5	19.5
1,000	30.8	16.3	19.9
1,100	36.7	18.4	12.7
1,200	38.7	19.1	13.3
1,300	40.7	19.8	13.8
1,400	45.5	20.7	14.6
1,500	47.0	21.5	15.1

## Steam Fired(WCSH Series)

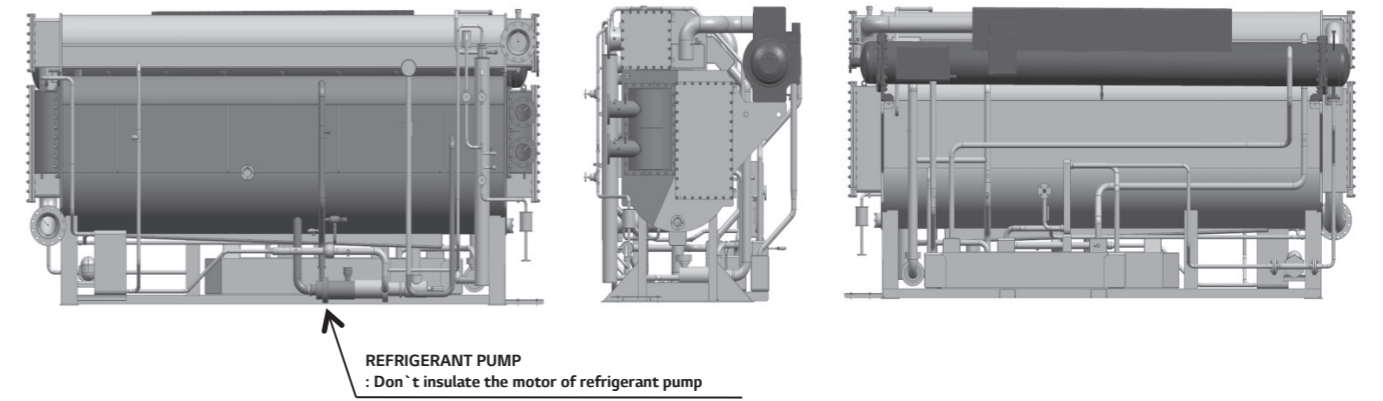

- 75mm FOR WARM SURFACE
- 25mm FOR WARM SURFACE
- 19mm FOR COLD SURFACE
- REMOVAL PART

**NOTE.**  
 • Material : Glass Wool, Galvanized Steel Plate, Nitrile-Butadiene Rubber(NBR)  
 1. Use noncombustible insulation material.  
 2. Do not insulate motor of refrigerant pump.  
 3. Insulation area includes piping.  
 4. The Chiller is coated with a anticorrosive paint at the factory.  
 Finish painting is typically performed in the field after insulating is complete.

Capacity(RT)	Hot Surface(m <sup>2</sup> )		Cold(m <sup>2</sup> )
	75mm	25mm	19mm
100	5.3	3.0	4.4
120	5.3	3.4	4.4
150	7.5	3.7	5.9
180	7.5	4.2	5.9
210	8.4	4.7	6.8
240	8.4	4.8	6.8
280	11.2	5.8	8.4
320	11.2	6.0	8.4
360	12.7	6.5	9.9
400	12.7	6.7	9.9
450	13.4	6.9	11.2
500	13.4	7.2	11.2
560	16.1	8.8	13.9
630	18.1	9.3	15
700	19.9	9.7	16.1
800	21.2	10.7	17.3
900	23.3	11.2	19.5
1,000	25.4	11.7	19.9
1,100	27.2	13.5	12.7
1,200	29.6	13.9	13.3
1,300	31.9	14.3	13.8
1,400	31.3	15.2	14.6
1,500	33.8	15.5	15.1

# Piping diagram

## Hot water driven absorption chiller (MH Type)



# Piping diagram

## Hot water driven absorption chiller (2H, 2N Type)



- \*GENERAL REMARKS ON PIPE-LAYING WORK
1. LSC supply boundary line. ( )
  2. See [OUTLINE] drawing for dimension, size of connections.
  3. 10kg/cm<sup>2</sup> is the maximum operation pressure of Chilled/Cooling water pipe line.
  4. See [CONTROL OF COOLING WATER TEMPERATURE] drawing for information of controller. ( )
  5. Provide separate chilled, cooling and hot water pumps for each absorption machine. Flow rate of chilled, cooling and hot water should confirm to the specifications.
  6. Provide a bleeder in the cooling water line for control of cooling water quality.
  7. Install a strainer having a mesh of 10 or so.

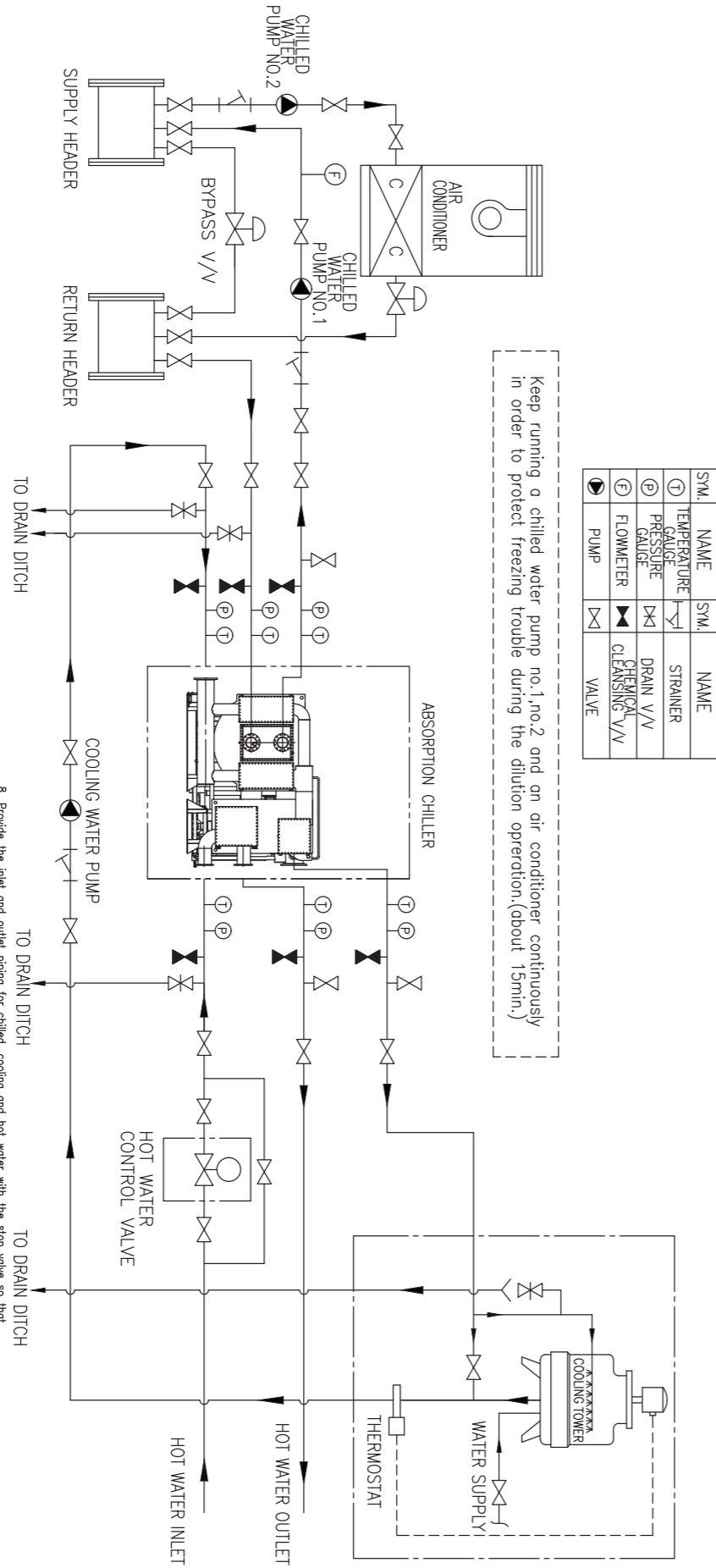

- 1) Install thermometers and pressure gauges at locations convenient for servicing in the inlet and outlet water lines.
- 2) Install air vent valves for water lines at a position above the absorption machine.
- 3) Install drain valves for water lines at a position bottom the absorption machine, and then extend them up to the ditch.
- 4) For chemical cleaning, install the stop valves for cleaning between the unit and each stop valve at the inlet or outlet.

SYM.	NAME	SYM.	NAME
①	TEMPERATURE GAUGE	Y	STRAINER
②	PRESSURE GAUGE	DK	DRAIN V/V
③	FLOWMETER	DK	CHEMICAL CLEANSING V/V
☉	PUMP	∇	VALVE

Keep running a chilled water pump no.1,no.2 and an air conditioner continuously in order to protect freezing trouble during the dilution operation.(about 15min.)

- \*GENERAL REMARKS ON PIPE-LAYING WORK
1. LSC supply boundary line. ( )
  2. See [OUTLINE] drawing for dimension, size of connections.
  3. 10kg/cm<sup>2</sup> is the maximum operation pressure of Chilled/Cooling water pipe line.
  4. See [CONTROL OF COOLING WATER TEMPERATURE] drawing for information of controller. ( )
  5. Provide separate chilled, cooling and hot water pumps for each absorption machine. Flow rate of chilled, cooling and hot water should confirm to the specifications.
  6. Provide a bleeder in the cooling water line for control of cooling water quality.
  7. Install a strainer having a mesh of 10 or so.

- 1) Install thermometers and pressure gauges at locations convenient for servicing in the inlet and outlet water lines.
- 2) Install air vent valves for water lines at a position above the absorption machine.
- 3) Install drain valves for water lines at a position bottom the absorption machine, and then extend them up to the ditch.
- 4) For chemical cleaning, install the stop valves for cleaning between the unit and each stop valve at the inlet or outlet.

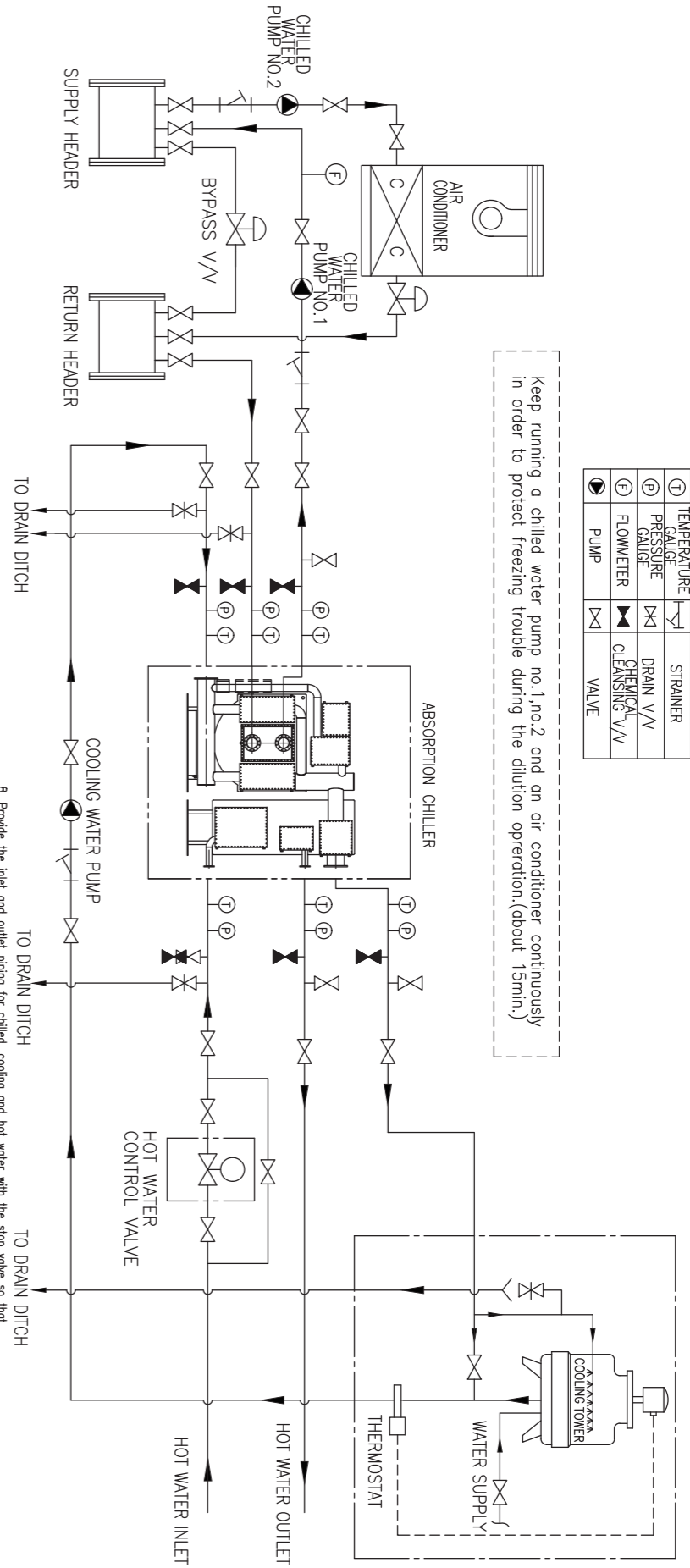



Keep running a chilled water pump no.1,no.2 and an air conditioner continuously in order to protect freezing trouble during the dilution operation.(about 15min.)

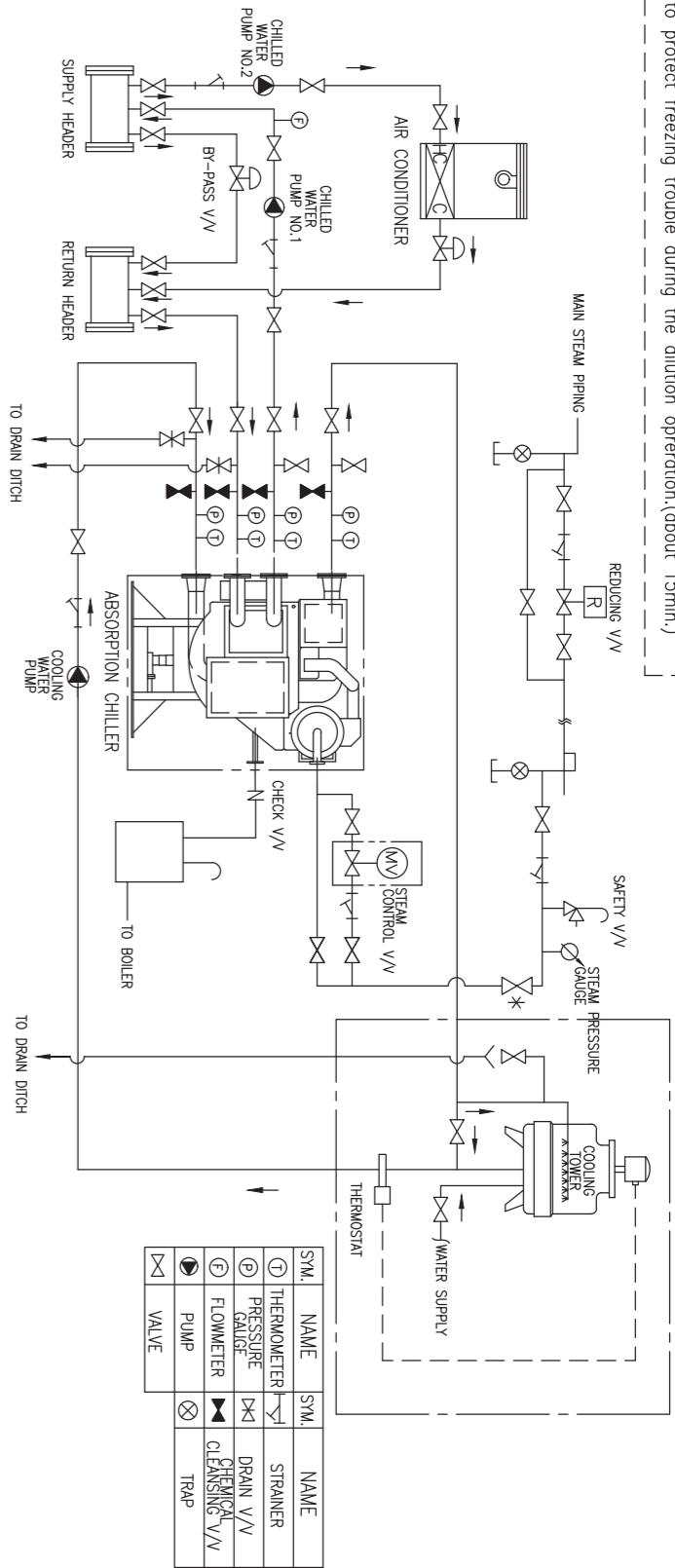

- GENERAL REMARKS ON PIPE-LAYING WORK
- The range of equipment to be supplied by the two-dot chain line.( )
  - For pipe diameter, pipe connections, etc., refer to the mechanical layout diagram. [OUTLINE]
  - The maximum operating pressure in the chilled and cooling water is 10Kg/cm<sup>2</sup>. [CONTROL OF COOLING WATER TEMPERATURE] ( )
  - Provide separate chilled and cooling water pumps for each absorption machine. Flow rate of chilled and cooling water should conform to the specifications.
  - Provide a bleeder in the cooling water line for control of cooling water quality.
  - Install a strainer having a mesh of 10 or so.
  - Install a steam stop v/v(\*) to shut off a steam line to a chiller when the chiller is not operate.

- Provide the inlet and outlet piping for chilled and cooling water with the stop valve so that the piping can be cleaned easily.
  - Install thermometers and pressure gauges at locations convenient for servicing in the inlet and outlet water lines.
  - Install air vent valves for water lines at a position above the absorption machine.
  - Install drain valves for water lines at a position bottom the absorption machine, and then extend them up to the ditch.
  - For chemical cleaning, install the stop valves for cleaning between the unit and each stop valve at the inlet or outlet.

Keep running a chilled water pump no.1,no.2 and an air conditioner continuously in order to protect freezing trouble during the dilution operation.(about 15min.)

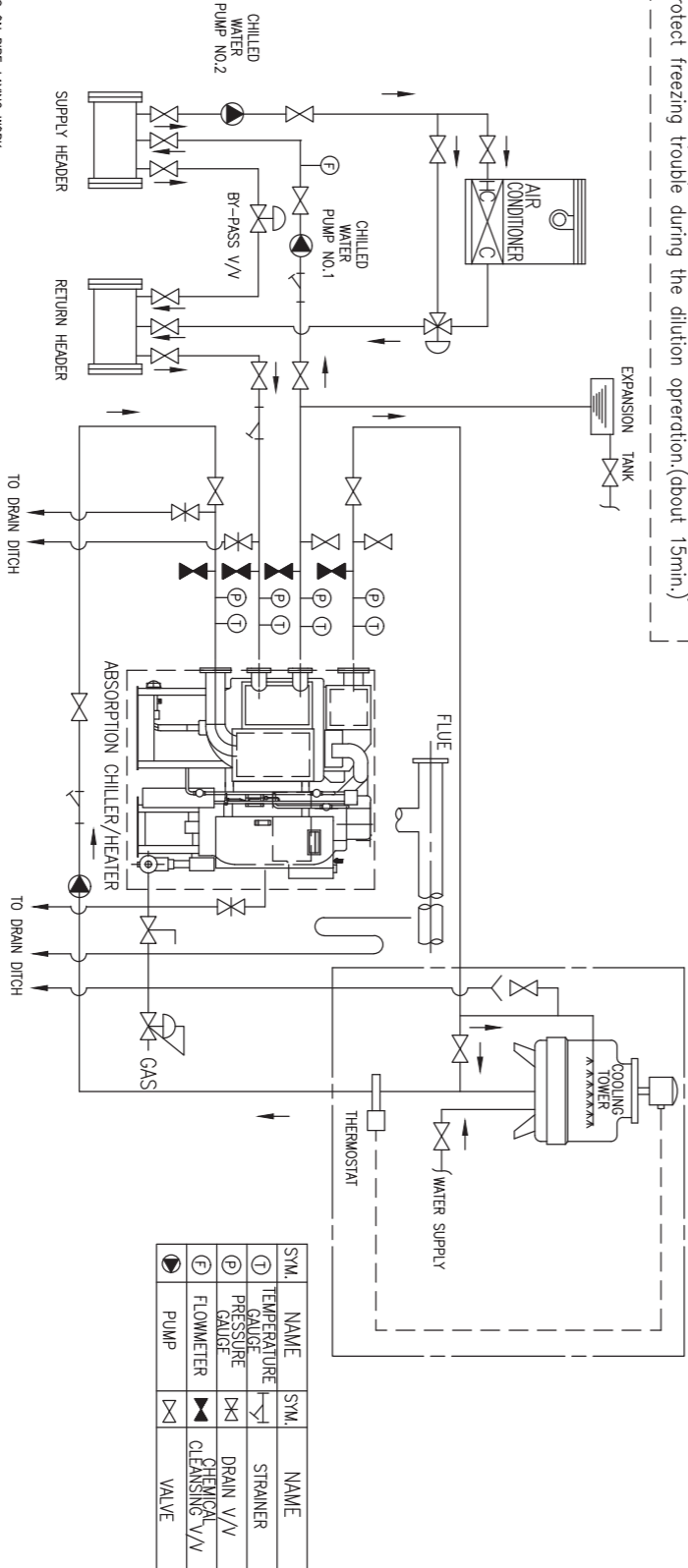

- \*GENERAL REMARKS ON PIPE-LAYING WORK
- LSC supply boundary line. ( )
  - See [OUTLINE] drawing for dimension, size of connections.
  - 10kg/cm<sup>2</sup> is the maximum operation pressure of Chilled/Cooling water pipe line.
  - See [CONTROL OF COOLING WATER TEMPERATURE] drawing for information of controller. ( )
  - Provide separate Chilled/Cooling water pumps for each absorption machine. Flow rate of Chilled/Cooling water should meet the specification, individually the specifications.
  - Place a bleeder at the Cooling water line for control of Cooling water quality.
  - Install a more or less 10-meshed strainer.
  - Flue and stack connection.
    - Flue and stack should be heat insulated with a condensate drain equipped.
    - Do not connect the flue to incinerator stack.
    - One individual stack for each chiller is recommendable. Common stack can be used if it is due to space limitation. However, each unit should be installed with a damper to prevent exhaust flowing backward when unit not in operation. Also, operator should always check if damper is opened before starting.
    - Draft regulator can be used, if static pressure inside the stack is unstable.

- Chilled/Cooling water pipe maintenance.
  - To ease maintenance, a stop valve should be placed around the Inlet/Outlet of Chilled/Cooling water supplying pipe line.
  - Place both temperature sensor and pressure gauge around the Inlet/Outlet of Chilled/Cooling water supplying pipe line.
  - Vent valve must be located higher than water levels of the Chilled/Cooling water headers.
  - A drain valve should be placed at lower part of between unit and stop valve of Chilled/Cooling supplying pipe line.
  - For chemical cleaning purposes, a valve should be placed at between unit and Inlet/Outlet stop valve.
- For safety reasons, place both manual and automatic stop valve at supplying pipe line.
  - When supplying gas for the first time, check if gas is supplied to unite properly.
  - Exhaust possible temon N<sub>2</sub>/CO<sub>2</sub> gas that could cause unstable combustion and failure ignition.
  - when chiller is not in operation for a long period, check 1,2) in before operation.

CONTROL OF COOLING WATER TEMPERATURE

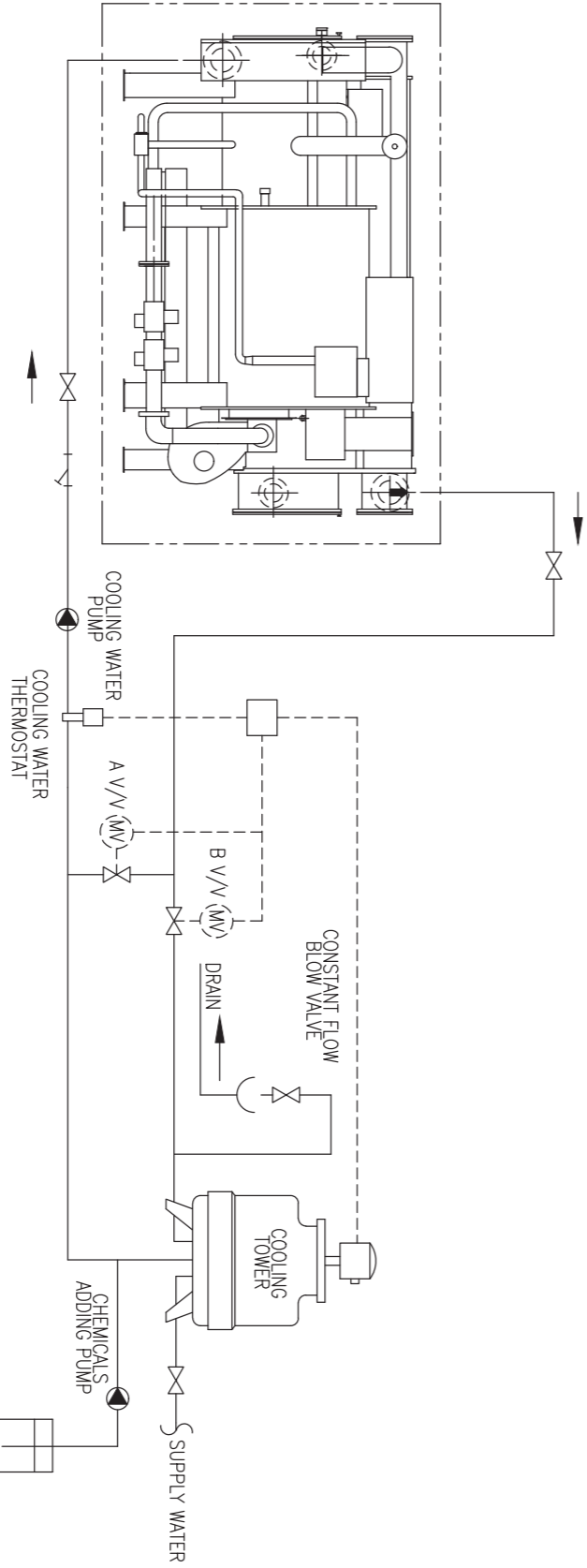

\* Ensure that the cooling water temperature does not fall more than 10°C below the design temperature. For example, if the cooling water inlet temperature is 32°C, ensure that the cooling water temperature does not fall below 22°C. During starting, however, a lower temperature is permissible until the machine reaches the rated capacity.

NOTE 1. Be sure to start and stop the fan by means of the cooling water thermostat.

2. Cooling water thermostat setting value  
(When the cooling water inlet temp. is 32°C)  
22°C and below ... off,  
25°C and above ... on

Tolerance Value: Under  $\pm 1^\circ\text{C}$  (After approaching the stable load condition)  
Tolerance Time : More than 2 minutes. per  $1^\circ\text{C}$  (After approaching the stable load condition)

WORK OUTSIDE THE AREA SURROUND BY THIS LINE(-----)  
IS NOT SUPPLIED BY LGC.

CONTROL OF COOLING WATER TEMPERATURE

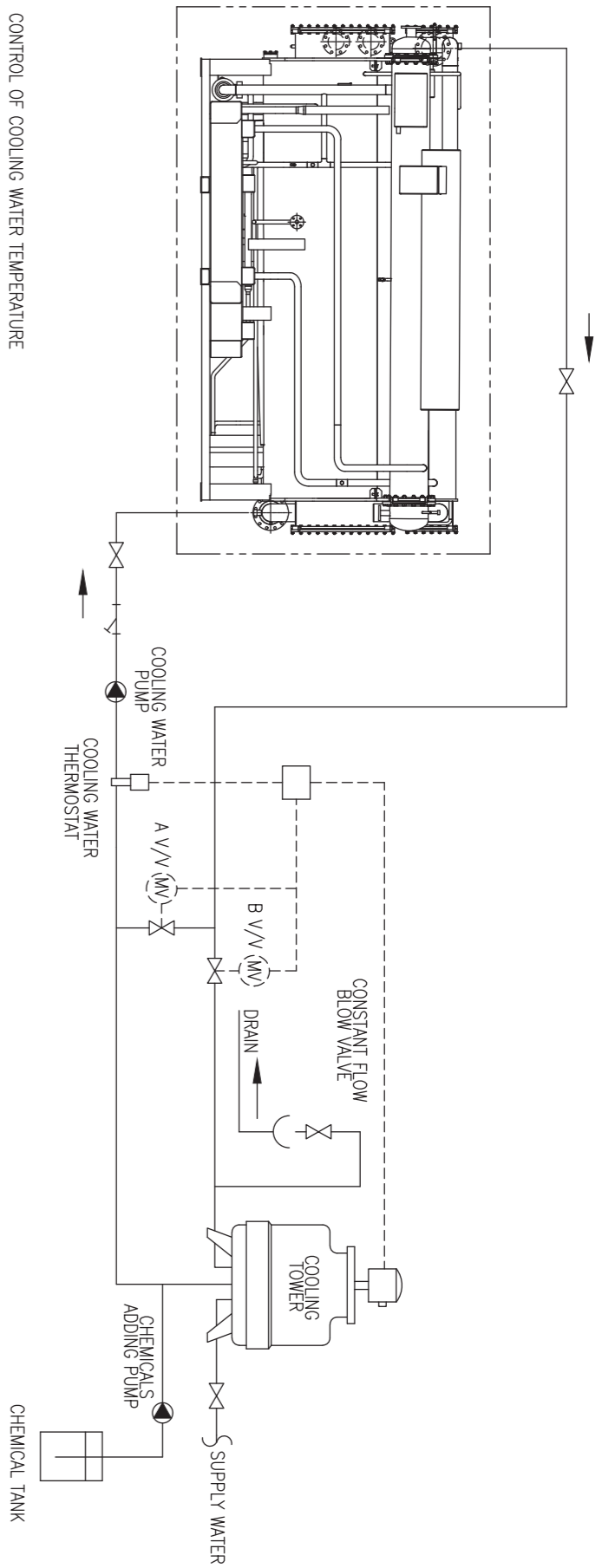

\* Ensure that the cooling water temperature does not fall more than 10°C below the design temperature. For example, if the cooling water inlet temperature is 32°C, ensure that the cooling water temperature does not fall below 22°C. During starting, however, a lower temperature is permissible until the machine reaches the rated capacity.

NOTE 1. Be sure to start and stop the fan by means of the cooling water thermostat.

2. Cooling water thermostat setting value  
(When the cooling water inlet temp. is 32°C)  
22°C and below ... off,  
25°C and above ... on

Tolerance Value: Under  $\pm 1^\circ\text{C}$  (After approaching the stable load condition)  
Tolerance Time : More than 2 minutes. per  $1^\circ\text{C}$  (After approaching the stable load condition)

WORK OUTSIDE THE AREA SURROUND BY THIS LINE(-----)  
IS NOT SUPPLIED BY LGC.

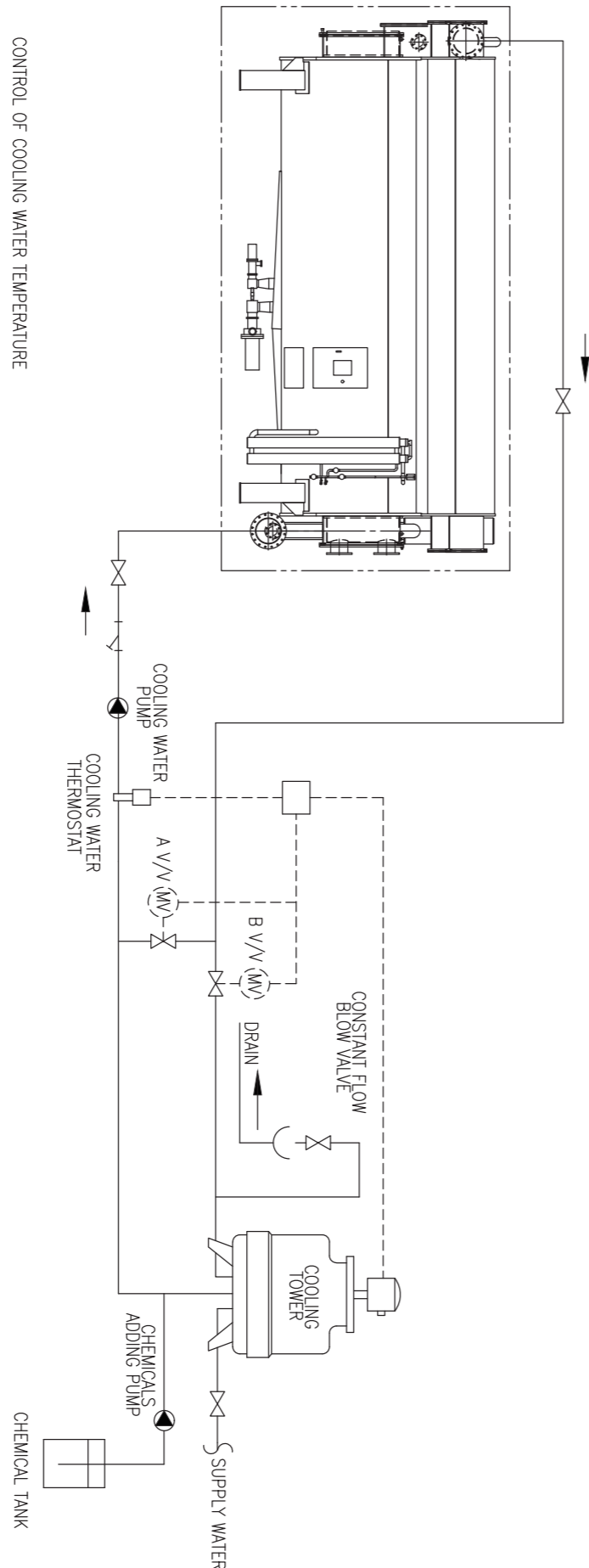

CONTROL OF COOLING WATER TEMPERATURE

\* Ensure that the cooling water temperature does not fall more than 10°C below the design temperature. For example, if the cooling water inlet temperature is 31°C, ensure that the cooling water temperature does not fall below 22°C. During starting, however, a lower temperature is permissible until the machine reaches the rated capacity.

NOTE 1. Be sure to start and stop the fan by means of the cooling water thermostat.

2. Cooling water thermostat setting value (When the cooling water inlet temp. is 31°C)  
 22°C and below ... off,  
 25°C and above ... on

Tolerance Value: Under ± 1°C (After approaching the stable load condition)  
 Tolerance Time : More than 2 minutes. per 1°C (After approaching the stable load condition)

# Standard of water quality

## Standard of water quality

The cooling water of an open-type recycling cooling tower lowers temperature of the cooling water using vaporized latent-heat and is reused. In this case, the water is evaporated and dissolved salts, Hardness materials, sulfate ion, etc. in the water will increase. Namely, condensation phenomena of such materials occurs in the water, and water quality will gradually

be degraded. As the water and air always come in contact with each other in the cooling tower, sulfurous acid gas, dust, sand, etc. in the atmosphere will mix into the water, further degrading the water quality. In the cooling water system, problems with water are caused by these factors. Typical problems are corrosion, scales and slimes.

Model	Cooling Water		Chilled Water		Tendency	
	One-Pass or Circulating	Make-Up Water	Circulating Water	Make-Up	Corrosion	Scale
pH(25°C)	6.5-8.0	6.5-8.0	6.5-8.0	6.5-8.0	0	0
Electrical Conductivity (25°C μs/cm)	Max.800	Max.200	Max.500	Max.200	0	0
Alkalinity(ppm)	Max.100	Max.50	Max.100	Max.50		0
Total Hardness(ppm)	Max.200	Max.50	Max.100	Max.50	0	
Chlorine Ion(ppm)	Max.200	Max.50	Max.100	Max.50	0	
Sulfuric Acid Ion(ppm)	Max.200	Max.50	Max.100	Max.50	0	
Total Ion(ppm)	Max.1.0	Max.0.3	Max.1.0	Max.0.3	0	
Sulfur Ion(ppm)	No trace	No trace	No trace	No trace	0	
Ammonium Ion(ppm)	Max.1.0	Max.1.0	Max.0.5	Max.0.2	0	
Silica(ppm)	Max.50	Max.30	Max.50	Max.30		0
Free Carbonic Acid(ppm)	*****	*****	Max.1.0	Max.1.0	0	

Combustion Sequence Diagram

Gas(Gas pressure : 900~4,000mmAq)

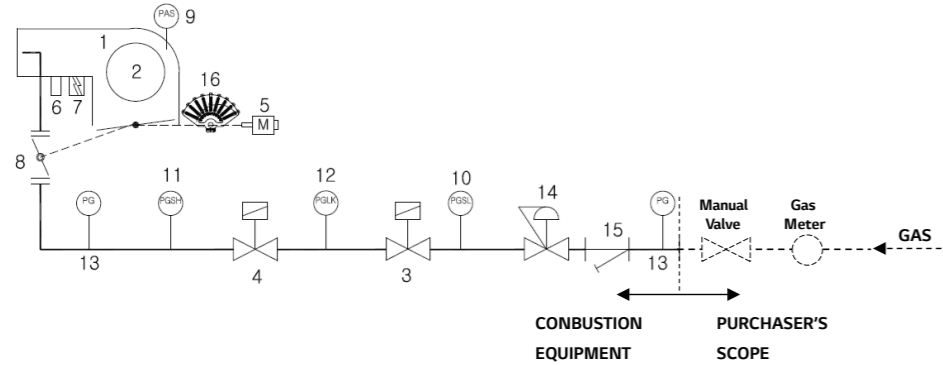

Gas(Gas pressure : 200mmAq)

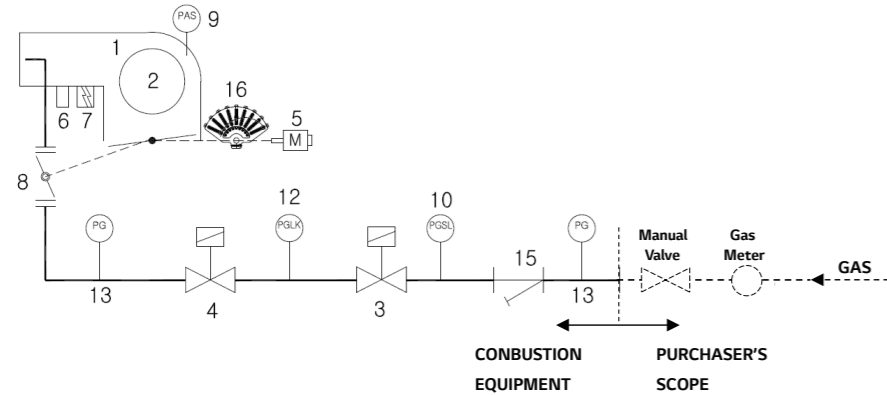

Part list

1. Burner
2. Sirocco fan
3. Safety shut-off valve
4. Safety shut-off valve
5. Damper motor
6. Flame detector
7. Ignition trans
8. Butterfly valve
9. Air pressure switch
10. Gas pressure low switch(PGSL)
11. Gas pressure high switch(PGSH)
12. Gas leak switch(PGLK)
13. Gas pressure gauge
14. Governor
15. Gas filter(Included in governor)
16. Sector regulator

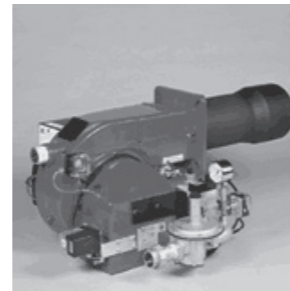

Flue and Stack Connection

1. Local regulations regarding exhaust of direct-fired burners must be adhered to. These instructions shown are typical and are not meant to supersede local codes in any way.
2. The steel stack should be lined on the interior surface to protect the stack from corrosion due to moisture in the exhaust gas.
3. The flue and stack must be heat insulated and provided with a condensate drain.
4. Do not connect the flue to an incinerator stack.
5. Place the top of the stack within a sufficient distance from the cooling towers to prevent contamination.
6. Provide a barometric draft regulator or damper if fluctuations or downdraft in static pressure are expected inside the flue. Some means of controlling the flue draft may be necessary to insure that proper combustion efficiency is maintained at all times.
7. If a common stack is to be used, exhaust must be prevented from flowing into the unit(s) that are not in operation.
8. The draft pressure at the flue flange should be designed for a maximum negative pressure of -5mmH<sub>2</sub>O.

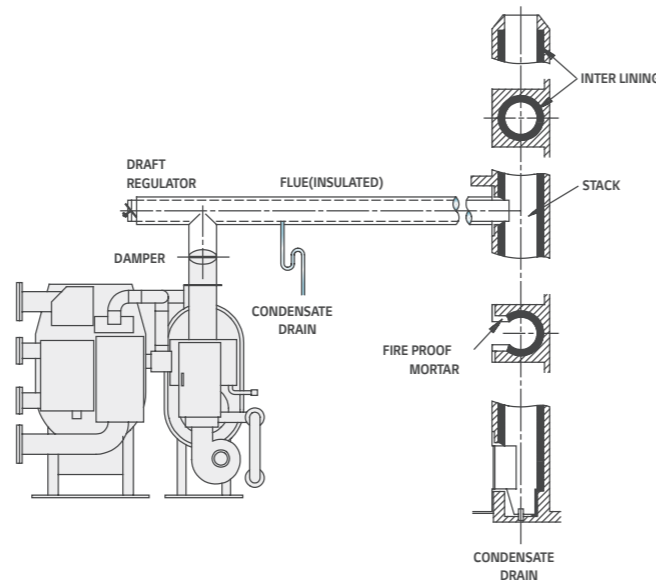

Direct fired absorption chiller(DH Type)

Model	Entrance Dimension of Total Unit				Entrance Dimension of 2-Sectional Shipment							
	Length mm	Width mm	Height mm	Weight ton	Low temperature generator(Upper+Lower)				High Temperature Generator			
					Length mm	Width mm	Height mm	Weight ton	Length mm	Width mm	Height mm	Weight ton
WCDH010	3,095	2,170	2,110	4.2	3,095	1,500	2,100	3.3	1,600	805	1,965	0.9
WCDH012	3,095	2,170	2,110	4.4	3,095	1,500	2,100	3.4	1,900	870	1,965	1.0
WCDH015	3,945	2,160	2,110	5.2	3,945	1,500	2,100	4.0	1,900	870	1,965	1.2
WCDH018	3,945	2,165	2,110	5.5	3,945	1,500	2,100	4.2	2,250	900	2,120	1.3
WCDH021	3,995	2,220	2,455	6.5	3,995	1,550	2,400	5.0	2,250	900	2,120	1.5
WCDH024	3,995	2,240	2,455	6.9	3,995	1,550	2,400	5.3	2,950	900	2,120	1.6
WCDH028	5,015	2,295	2,455	7.9	5,015	1,550	2,400	6.1	2,950	900	2,120	1.8
WCDH032	5,015	2,295	2,455	8.2	5,015	1,550	2,400	6.2	2,900	1,050	2,400	2.0
WCDH036	5,090	2,500	2,630	10.1	5,090	1,750	2,600	7.6	2,900	1,050	2,400	2.5
WCDH040	5,090	2,585	2,630	10.6	5,090	1,750	2,600	7.8	3,300	1,100	2,600	2.8
WCDH045	5,100	2,855	2,965	12.5	5,100	1,850	2,950	9.4	3,300	1,100	2,600	3.1
WCDH050	5,100	2,925	2,965	13.1	5,100	1,850	2,950	9.8	3,100	2,150	3,000	3.3
WCDH056	5,510	3,095	3,335	17.0	5,510	2,100	3,300	12.8	2,100	1,400	3,100	4.2
WCDH063	5,720	3,220	3,335	18.3	5,720	2,100	3,300	13.8	3,550	1,350	3,100	4.5
WCDH070	6,210	3,220	3,335	19.6	6,210	2,100	3,370	14.9	3,400	1,500	3,600	4.7
WCDH080	5,835	3,870	3,590	23.6	5,835	2,610	3,555	18.4	3,400	1,500	3,600	5.2
WCDH090S	6,330	3,990	3,640	26.8	6,330	2,610	3,555	20.6	3,400	1,500	3,600	6.2
WCDH100S	6,790	3,990	3,640	29.1	6,790	2,610	3,555	21.9	3,700	1,500	3,600	7.2
WCDH110S	6,340	4,270	3,820	35.5	6,340	2,700	3,785	27.6	3,950	1,500	3,600	7.9
WCDH120S	6,860	4,370	3,820	39.5	6,860	2,700	3,785	30.6	4,100	1,650	3,600	8.9
WCDH130S	7,360	4,370	3,820	43.4	7,360	2,700	3,785	33.8	4,400	1,650	3,600	9.6
WCDH140S	6,840	4,770	3,880	44.1	6,840	2,700	3,850	33.8	4,650	1,650	3,600	10.3
WCDH150S	7,560	4,920	3,880	48.2	7,560	2,700	3,850	37.1	4,750	1,790	3,800	11.1

Model	Entrance Dimension of 3-Sectional Shipment											
	Upper Shell				Low Shell				High Temperature Generator			
	Length mm	Width mm	Height mm	Weight ton	Length mm	Width mm	Height mm	Weight ton	Length mm	Width mm	Height mm	Weight ton
WCDH010	3,095	1,150	510	0.6	3,095	1,500	1,980	2.7	1,600	805	1,965	0.9
WCDH012	3,095	1,150	510	0.6	3,095	1,500	1,980	2.8	1,900	870	1,965	1.0
WCDH015	3,945	1,150	510	0.8	3,945	1,500	1,980	3.2	1,900	870	1,965	1.2
WCDH018	3,945	1,150	510	0.8	3,945	1,500	1,980	3.4	2,250	900	2,120	1.3
WCDH021	3,995	1,200	510	1.0	3,995	1,550	2,150	4.0	2,250	900	2,120	1.5
WCDH024	3,995	1,200	510	1.0	3,995	1,550	2,150	4.3	2,950	900	2,120	1.6
WCDH028	5,015	1,200	510	1.2	5,015	1,550	2,160	4.9	2,950	900	2,120	1.8
WCDH032	5,015	1,200	510	1.1	5,015	1,550	2,160	5.1	2,900	1,050	2,400	2.0
WCDH036	5,090	1,350	550	1.4	5,090	1,750	2,500	6.2	2,900	1,050	2,400	2.5
WCDH040	5,090	1,350	550	1.4	5,090	1,750	2,500	6.4	3,300	1,100	2,600	2.8
WCDH045	5,100	1,500	650	1.8	5,100	1,850	2,600	7.6	3,300	1,100	2,600	3.1
WCDH050	5,100	1,500	650	1.8	5,100	1,850	2,600	8.0	3,100	2,150	3,000	3.3
WCDH056	5,510	1,550	800	2.5	5,510	2,100	2,950	10.3	2,100	1,400	3,100	4.2
WCDH063	5,720	1,550	800	2.8	5,720	2,100	2,840	11.0	3,550	1,350	3,100	4.5
WCDH070	6,210	1,500	800	3.0	6,210	2,100	2,840	11.9	3,400	1,500	3,600	4.7
WCDH080	5,550	1,580	1,030	3.5	5,550	2,610	3,000	14.9	3,400	1,500	3,600	5.2
WCDH090S	6,150	1,580	1,030	3.8	6,150	2,610	3,000	16.8	3,400	1,500	3,600	6.2
WCDH100S	6,560	1,580	1,030	4.0	6,560	2,610	3,000	17.9	3,700	1,500	3,600	7.2
WCDH110S	6,465	1,700	1,100	4.6	6,465	2,700	2,990	23.0	3,950	1,500	3,600	7.9
WCDH120S	6,865	1,700	1,100	5.0	6,865	2,700	2,990	25.6	4,100	1,650	3,600	8.9
WCDH130S	7,265	1,700	1,100	5.5	7,265	2,700	2,990	28.3	4,400	1,650	3,600	9.6
WCDH140S	7,090	1,960	1,150	5.8	6,860	2,700	3,140	28.0	4,650	1,650	3,600	10.3
WCDH150S	7,590	1,960	1,150	6.3	7,360	2,700	3,140	30.8	4,750	1,790	3,800	11.1

Note:

1. The above DATA corresponds to the standard model listed in the catalog. Equipment size can be changed.
2. Since this is the size of the equipment only, please consider the carrying tool(Such as the ski dai) margin.
3. The weight above is the maximum carrying weight of the equipment(Without absorbent).
4. The size of the special sectional shipment may vary depending on the cut area. If the entrance is narrow, please ask for a question by providing the entrance size.

# Multi-Sectional shipment



## Steam absorption chiller(SH Type)

Model	Entrance Dimension of Total Unit				Entrance Dimension of 3-Sectional Shipment															
	Length	Width	Height	Weight	Upper Shell				Lower Shell				High Temperature Generator							
					Length	Width	Height	Weight	Length	Width	Height	Weight	Length	Width	Height	Weight				
mm	mm	mm	ton	mm	mm	mm	ton	mm	mm	mm	ton	mm	mm	mm	ton	mm	mm	mm	ton	
WCSH010	2,950	2,000	2,105	3.5	2,950	1,180	530	0.5	2,950	1,520	2,010	2.6	2,600	500	700	0.4				
WCSH012	2,950	2,000	2,105	3.8	2,950	1,180	530	0.6	2,950	1,520	2,010	2.8	2,600	500	700	0.4				
WCSH015	3,920	2,000	2,110	4.4	3,920	1,180	530	0.7	3,920	1,520	2,010	3.2	3,620	500	700	0.5				
WCSH018	3,920	2,000	2,150	4.8	3,920	1,180	530	0.8	3,920	1,520	2,010	3.5	3,620	500	700	0.5				
WCSH021	3,920	2,070	2,455	5.7	3,920	1,250	600	1.0	3,920	1,520	2,155	4.1	3,650	530	790	0.6				
WCSH024	3,920	2,070	2,455	6.0	3,920	1,250	600	1.0	3,920	1,520	2,155	4.4	3,650	530	790	0.6				
WCSH028	4,940	2,140	2,455	6.9	4,940	1,250	600	1.2	4,940	1,520	2,155	4.9	4,680	530	790	0.8				
WCSH032	4,940	2,140	2,455	7.1	4,940	1,250	600	1.2	4,940	1,520	2,155	5.1	4,680	530	790	0.8				
WCSH036	5,000	2,270	2,630	8.6	5,000	1,385	670	1.4	5,000	1,730	2,550	6.3	4,730	630	850	0.9				
WCSH040	5,000	2,270	2,630	9.6	5,000	1,385	670	1.5	5,000	1,730	2,550	7.1	4,730	630	850	1.0				
WCSH045	5,030	2,515	2,990	10.4	5,030	1,520	710	1.8	5,030	1,910	2,625	7.5	4,860	720	920	1.1				
WCSH050	5,030	2,515	2,990	12.2	5,030	1,520	710	2.1	5,030	1,910	2,625	8.7	4,860	720	920	1.4				
WCSH056	5,185	2,680	3,340	15.0	5,185	1,600	870	2.7	5,185	2,140	2,980	10.7	4,900	770	1,070	1.6				
WCSH063	5,685	2,680	3,340	15.6	5,685	1,600	870	2.8	5,685	2,140	2,980	11.2	5,450	770	1,070	1.6				
WCSH070	6,185	2,680	3,340	18.2	6,185	1,600	870	3.3	6,185	2,140	2,980	13.0	5,940	770	1,070	1.9				
WCSH080	5,835	3,160	3,590	19.8	5,835	1,770	1,090	3.5	5,835	2,570	2,840	14.4	5,600	1,000	1,230	1.9				
WCSH090	6,330	3,160	3,590	21.5	6,330	1,770	1,090	3.6	6,330	2,570	2,840	15.8	6,000	1,000	1,230	2.1				
WCSH100	6,790	3,160	3,590	23.7	6,790	1,770	1,090	4.0	6,790	2,570	2,840	17.4	6,530	1,000	1,230	2.3				
WCSH110	6,340	3,250	3,860	27.7	6,340	2,200	1,140	4.2	6,340	2,890	3,000	21.0	6,000	930	1,230	2.5				
WCSH120	6,860	3,250	3,860	30.4	6,860	2,200	1,140	4.5	6,860	2,890	3,000	23.2	6,990	930	1,230	2.7				
WCSH130	7,360	3,250	3,860	32.7	7,360	2,200	1,140	4.8	7,360	2,890	3,000	25.1	6,000	930	1,230	2.8				
WCSH140	7,060	3,590	3,880	36.7	7,060	2,300	1,170	5.6	7,060	3,500	3,000	28.1	6,540	950	1,310	3.0				
WCSH150	7,560	3,590	3,880	39.2	7,560	2,300	1,170	5.8	7,560	3,500	3,000	30.4	7,040	950	1,310	3.0				

## Hot water driven absorption chiller(MH Type)

Model	Entrance Dimension of Total Unit				Entrance Dimension of 2-Sectional Shipment											
	Length	Width	Height	Weight	Lower Shell				High Temperature Generator							
					Length	Width	Height	Weight	Length	Width	Height	Weight				
mm	mm	mm	ton	mm	mm	mm	ton	mm	mm	mm	ton	mm	mm	mm	ton	
WCMH008	2,790	1,600	2,370	3.2	2,790	1,280	750	1.1	2,790	1,600	1,980	2.1				
WCMH009	2,790	1,600	2,370	3.3	2,790	1,280	750	1.2	2,790	1,600	1,980	2.1				
WCMH011	3,700	1,500	2,370	3.8	3,700	1,280	750	1.3	3,700	1,500	1,980	2.5				
WCMH014	3,700	1,500	2,370	4.0	3,700	1,280	750	1.4	3,700	1,500	1,980	2.6				
WCMH016	3,850	1,560	2,715	5.0	3,850	1,200	880	1.8	3,850	1,560	2,160	3.3				
WCMH018	3,850	1,560	2,715	5.1	3,850	1,200	880	1.8	3,850	1,560	2,160	3.3				
WCMH021	4,870	1,560	2,715	5.9	4,870	1,200	880	2.1	4,870	1,560	2,160	3.8				
WCMH024	4,870	1,560	2,715	6.1	4,870	1,200	880	2.1	4,870	1,560	2,160	4.0				
WCMH027	4,870	2,000	2,940	8.2	4,870	1,430	880	2.9	4,870	2,000	2,550	5.3				
WCMH030	4,870	2,000	2,940	8.5	4,870	1,430	880	3.0	4,870	2,000	2,550	5.5				
WCMH034	4,940	1,940	3,330	10.4	4,940	1,540	935	3.6	4,940	2,045	2,430	6.8				
WCMH038	4,940	1,940	3,330	10.6	4,940	1,540	935	3.7	4,940	2,045	2,430	6.9				
WCMH042	4,940	2,045	3,540	12.2	4,940	1,870	1,100	4.3	4,940	2,045	2,840	7.9				
WCMH047	5,480	2,045	3,570	13.1	5,480	1,870	1,100	4.6	5,480	2,045	2,840	8.5				
WCMH053	5,980	2,045	3,570	13.9	5,980	1,870	1,100	4.9	5,980	2,045	2,840	9.0				
WCMH060	5,700	2,340	3,900	19.4	5,700	2,170	1,210	6.8	5,700	2,340	3,000	12.6				
WCMH068	6,200	2,340	3,900	20.5	6,200	2,170	1,210	7.2	6,200	2,340	3,000	13.3				
WCMH075	6,730	2,340	3,900	22.5	6,730	2,170	1,210	7.9	6,730	2,340	3,000	14.6				
WCMH083	6,270	4,200	3,000	23.4	6,270	2,310	1,430	8.2	6,270	2,650	2,990	15.2				
WCMH090	6,795	4,200	3,000	25.3	6,795	2,310	1,430	8.9	6,795	2,650	2,990	16.4				
WCMH098	7,295	4,200	3,000	27.5	7,295	2,310	1,430	9.6	7,295	2,650	2,990	17.9				
WCMH105	6,830	4,410	3,000	30.5	6,830	2,530	1,760	10.7	6,830	2,910	3,140	19.8				
WCMH113	7,330	4,410	3,000	31.9	7,330	2,530	1,760	11.2	7,330	2,910	3,140	20.7				
WCMH120	7,850	4,410	3,000	34.3	7,850	2,530	1,760	12.0	7,850	2,910	3,140	22.3				
WCMH135	8,350	4,410	3,000	37.0	8,350	2,530	1,760	13.0	8,350	2,910	3,140	24.1				

- Note:
- The above DATA corresponds to the standard model listed in the catalog. Equipment size can be changed.
  - Since this is the size of the equipment only, please consider the carrying tool(Such as the ski dai) margin.
  - The weight above is the maximum carrying weight of the equipment(Without absorbent).
  - The size of the special sectional shipment may vary depending on the cut area. If the entrance is narrow, please ask for a question by providing the entrance size.

# Multi-Sectional shipment



## Hot water driven absorption chiller(2H/2N Type)

Model	Entrance Dimension of Total Unit				Entrance Dimension of 2-Sectional Shipment											
	Length	Width	Height	Weight	Low Temperature Generator(Upper+Lower)				High Temperature Generator							
					Length	Width	Height	Weight	Length	Width	Height	Weight				
mm	mm	mm	ton	mm	mm	mm	ton	mm	mm	mm	ton	mm	mm	mm	ton	
WC2H/WC2N008	2,790	2,180	2,310	4.5	2,790	1,500	2,310	2.8	2,790	760	2,280	1.8				
WC2H/WC2N009	2,790	2,180	2,310	4.7	2,790	1,500	2,310	2.8	2,790	760	2,280	1.8				
WC2H/WC2N011	3,810	2,090	2,310	5.5	3,810	1,410	2,310	3.3	3,810	760	2,280	2.2				
WC2H/WC2N014	3,810	2,090	2,310	5.7	3,810	1,410	2,310	3.4	3,810	760	2,280	2.3				
WC2H/WC2N016	3,850	2,210	2,675	7.3	3,850	1,460	2,675	4.4	3,850	840	2,490	2.8				
WC2H/WC2N018	3,850	2,210	2,675	7.4	3,850	1,460	2,675	4.5	3,850	840	2,490	2.9				
WC2H/WC2N021	4,840	2,210	2,675	8.6	4,840	1,460	2,675	5.2	4,840	840	2,490	3.4				
WC2H/WC2N024	4,840	2,210	2,675	8.9	4,840	1,460	2,675	5.4	4,840	840	2,490	3.5				
WC2H/WC2N027	4,840	2,500	2,770	11.0	4,840	1,630	2,770	6.5	4,840	980	2,670	4.5				
WC2H/WC2N030	4,840	2,500	2,770	11.3	4,840	1,630	2,770	6.7	4,840	980	2,670	4.6				
WC2H/WC2N034	4,930	2,710	3,120	14.3	4,930	1,680	3,120	8.1	4,930	1,130	3,000	6.2				
WC2H/WC2N038	4,930	2,710	3,120	14.7	4,930	1,680	3,120	8.3	4,930	1,130	3,000	6.3				
WC2H/WC2N042	4,955	2,940	3,370	17.5	4,955	1,880	3,370	10.6	4,955	1,160	3,140	6.9				
WC2H/WC2N047	5,500	2,940	3,370	18.8	5,500	1,880	3,370	11.4	5,500	1,160	3,140	7.4				
WC2H/WC2N053	6,000	2,940	3,370	20.3	6,000	1,880	3,370	12.2	6,000	1,160	3,140	8.1				
WC2H/WC2N060	5,680	3,400	3,725	24.9	5,680	2,180	3,725	15.2	5,680	1,420	3,600	9.7				
WC2H/WC2N068	6,180	3,400	3,725	26.8	6,180	2,180	3,725	16.3	6,180	1,420	3,600	10.5				
WC2H/WC2N075	6,700	3,400	3,725	29.0	6,700	2,180	3,725	17.9	6,700	1,420	3,600	11.1				
WC2H/WC2N083	6,270	4,070	3,890	31.4	6,270	2,650	3,800	17.9	6,270	1,640	3,860	13.5				
WC2H/WC2N090	6,795	4,070	3,890	34.3	6,795	2,650	3,800	19.6	6,795							

# Outline & Foundation

Direct fired absorption chiller & heater



## WCDH

- All external water piping are to be provided with welded ANSI 150PSIG RF flanges by the customer.
- Installation and service clearance as follows :  
 Longitudinal distance - 1,000mm  
 Top - 200mm  
 Control panel side - 1,200mm
- Please refer to the LG Electronics drawings for the piping direction.

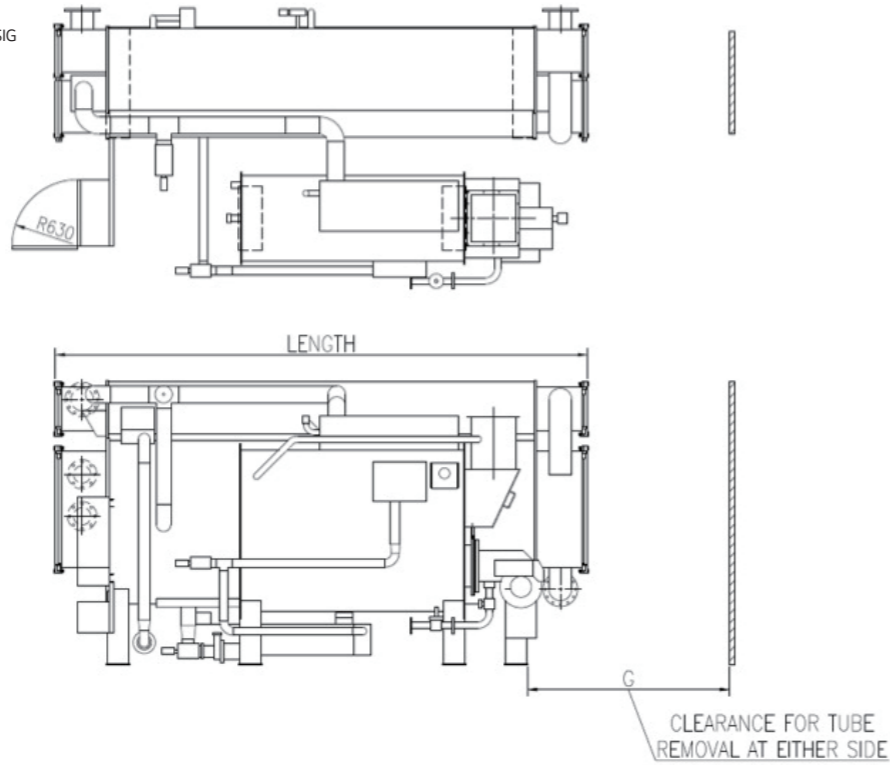

Model	Dimension(mm)			Nozzle Connection(B)				Clearance(mm)
	Length	Width	Height	A	B	C	D	
WCDH010S	2,895	2,100	2,070	5	4	4	5	2,400
WCDH012S	2,895	2,100	2,070	5	4	4	5	2,400
WCDH015S	3,745	2,090	2,070	5	4	4	5	3,400
WCDH018S	3,745	2,095	2,070	5	4	4	5	3,400
WCDH021S	3,795	2,150	2,415	6	5	5	6	3,400
WCDH024S	3,795	2,170	2,415	6	5	5	6	3,400
WCDH028S	4,815	2,225	2,415	8	6	6	8	4,500
WCDH032S	4,815	2,225	2,415	8	6	6	8	4,500
WCDH036S	4,890	2,430	2,590	8	6	6	8	4,500
WCDH040S	4,890	2,515	2,590	8	6	6	8	4,500
WCDH045S	4,900	2,785	2,925	10	8	8	10	4,500
WCDH050S	4,900	2,855	2,925	10	8	8	10	4,500
WCDH056S	5,310	3,025	3,295	12	8	8	12	4,500
WCDH063S	5,520	3,150	3,295	12	8	8	12	5,200
WCDH070S	6,010	3,150	3,295	12	8	8	12	5,700

# Outline & Foundation

Direct fired absorption chiller & heater



## WCDH

- All external water piping are to be provided with welded ANSI 150PSIG RF flanges by the customer.
- Installation and service clearance as follows :  
 Longitudinal distance - 1,000mm  
 Top - 200mm  
 Control panel side - 1,200mm
- Please refer to the LG Electronics drawings for the piping direction.

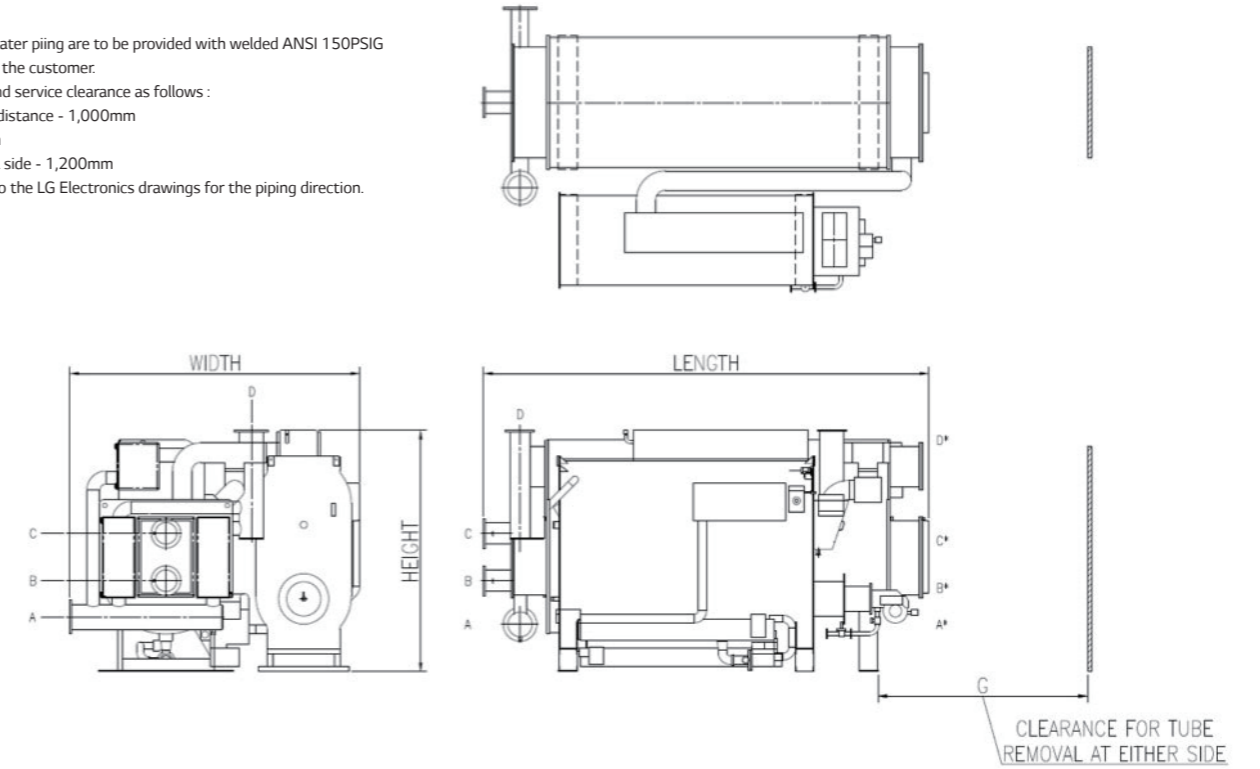

Model	Dimension(mm)			Nozzle Connection(B)				Clearance(mm)
	Length	Width	Height	A	B	C	D	
WCDH080S	5,635	3,800	3,550	14	10	10	14	5,200
WCDH090S	6,130	3,920	3,600	14	10	10	14	5,700
WCDH100S	6,590	3,920	3,600	14	10	10	14	6,200
WCDH110S	6,140	4,200	3,780	16	12	12	16	5,700
WCDH120S	6,660	4,300	3,780	16	12	12	16	6,200
WCDH130S	7,160	4,300	3,780	16	12	12	16	6,700
WCDH140S	6,640	4,700	3,840	16	14	14	16	6,200
WCDH150S	7,360	4,850	3,840	16	14	14	16	6,700

### WCDH

1. The foundation and the floor must be sufficiently strong to support the unit weight.
2. Provide a flow drain near chiller foundation.
3. Only if foundation anchoring is required, anchor bolts, nuts and washers, shall be supplied together with chiller. Anchor bolts must be fixed on the foundation prior to chiller installation.
4. Unit must be leveled before startup.  
(Horizontal level must be below than 2mm/1,000mm)

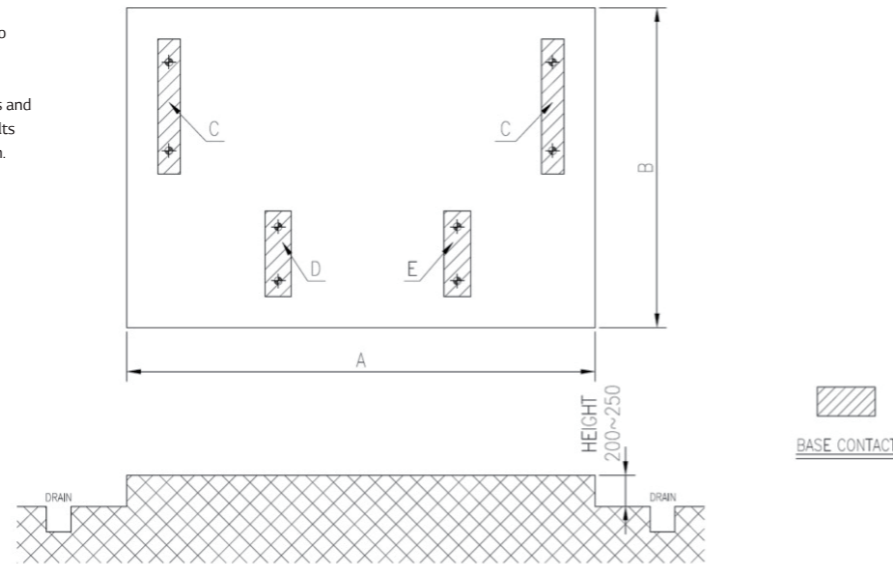

### WCDN

1. All external water piping are to be provided with welded ANSI 150PSIG RF flanges by the customer.
2. Installation and service clearance as follows :  
Longitudinal distance - 1,000mm  
Top - 200mm  
Control panel side - 1,200mm
3. Please refer to the LG Electronics drawings for the piping direction.

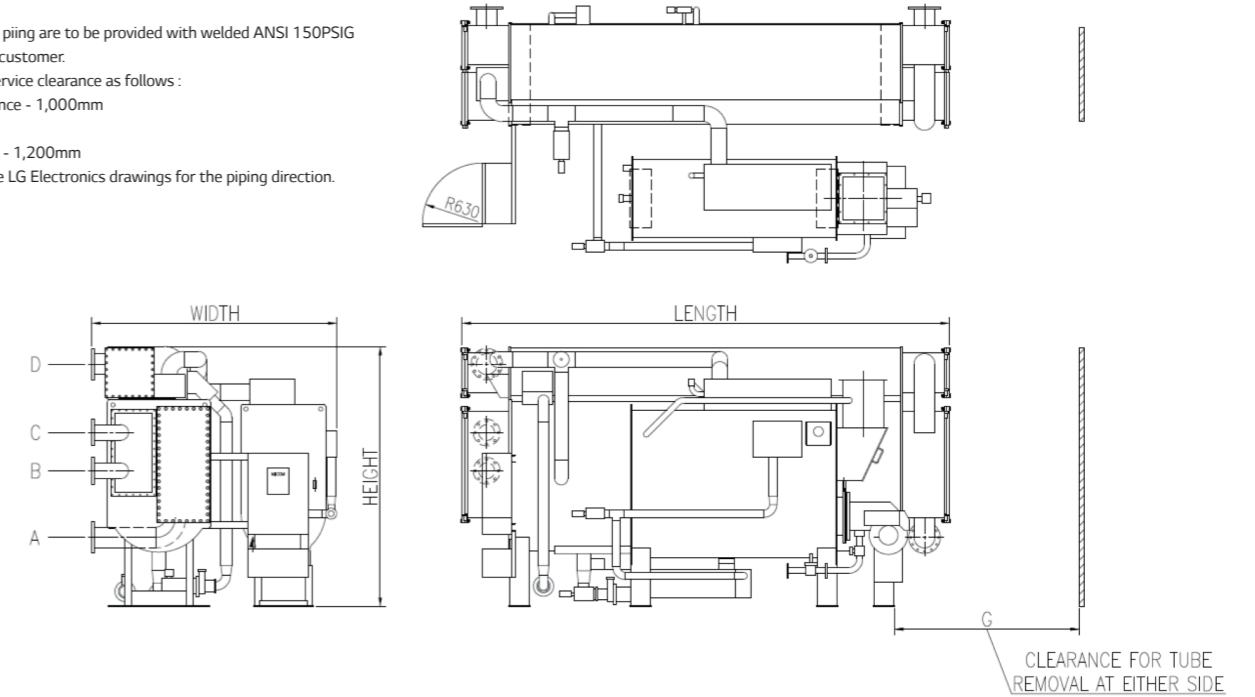

Model	Dimension(mm)		Weight(ton)			
	A	B	C	D	E	Total
WCDH010S	2,500	2,000	2.0	0.6	0.8	5.4
WCDH012S	2,500	2,000	2.1	0.6	0.8	5.6
WCDH015S	3,500	2,000	2.4	0.7	0.9	6.4
WCDH018S	3,500	2,100	2.5	0.9	1.1	7.0
WCDH021S	3,500	2,150	3.2	0.9	1.1	8.4
WCDH024S	3,500	2,150	3.4	0.9	1.2	8.9
WCDH028S	4,500	2,250	4.1	1.0	1.2	10.4
WCDH032S	4,500	2,250	4.1	1.1	1.5	10.8
WCDH036S	4,500	2,500	5.0	1.2	2.0	13.2
WCDH040S	4,500	2,550	5.2	1.3	2.3	14.0
WCDH045S	4,500	2,900	6.1	1.5	2.3	16.0
WCDH050S	4,500	2,900	6.4	1.6	2.8	17.2
WCDH056S	4,500	3,100	8.3	1.9	2.9	21.4
WCDH063S	5,050	3,300	9.1	2.8	3.0	24.0
WCDH070S	5,550	3,300	9.9	3.0	4.4	27.2
WCDH080S	5,050	3,750	12.2	3.2	4.8	32.4
WCDH090S	5,550	4,000	13.7	4.3	6.5	38.2
WCDH100S	6,100	4,000	14.9	5.0	7.5	42.2
WCDH110S	5,150	4,150	18.1	5.5	8.2	49.9
WCDH120S	5,700	4,150	20.2	6.1	9.1	55.6
WCDH130S	6,200	4,150	22.4	6.7	10.0	61.5
WCDH140S	5,700	4,600	23.0	7.3	10.9	64.2
WCDH150S	6,200	4,600	25.1	8.0	11.9	70.1

Model	Dimension(mm)			Nozzle Connection(B)				Clearance(mm)
	Length	Width	Height	A	B	C	D	
WCDN010	3,165	2,000	2,070	5	4	4	5	2,400
WCDN012	3,165	2,045	2,070	5	4	4	5	2,400
WCDN015	3,745	2,095	2,070	5	4	4	5	3,400
WCDN018	3,665	2,095	2,070	5	4	4	5	3,400
WCDN021	3,705	2,150	2,415	6	5	5	6	3,400
WCDN024	3,795	2,170	2,415	6	5	5	6	3,400
WCDN028	4,725	2,320	2,415	8	6	6	8	4,500
WCDN032	4,725	2,260	2,415	8	6	6	8	4,500
WCDN036	4,890	2,425	2,590	8	6	6	8	4,500
WCDN040	4,890	2,545	2,590	8	6	6	8	4,500
WCDN045	4,900	2,840	2,925	10	8	8	10	4,500
WCDN050	5,205	2,840	2,925	10	8	8	10	4,500
WCDN056	5,050	3,350	3,295	12	8	8	12	4,500
WCDN063	5,495	3,275	3,295	12	8	8	12	5,200
WCDN070	6,005	3,255	3,295	12	8	8	12	5,700
WCDN080	5,635	3,945	3,600	14	10	10	14	5,200
WCDN090	6,160	4,140	3,600	14	10	10	14	5,700
WCDN100	6,600	3,920	3,600	14	10	10	14	6,200
WCDN110	6,140	4,530	3,800	16	12	12	16	5,700
WCDN120	6,800	4,500	3,800	16	12	12	16	6,200
WCDN130	7,160	4,500	3,800	16	12	12	16	6,700
WCDN140	6,800	4,700	4,040	16	14	14	16	6,200
WCDN150	7,160	4,850	4,040	16	14	14	16	6,700

### WCDN

1. The foundation and the floor must be sufficiently strong to support the unit weight.
2. Provide a flow drain near chiller foundation.
3. Only if foundation anchoring is required, anchor bolts and washers, shall be supplied together with chiller. Anchor bolts must be fixed on the foundation prior to chiller installation.
4. Unit must be leveled before startup.  
(Horizontal level must be below than 2mm/1,000mm)

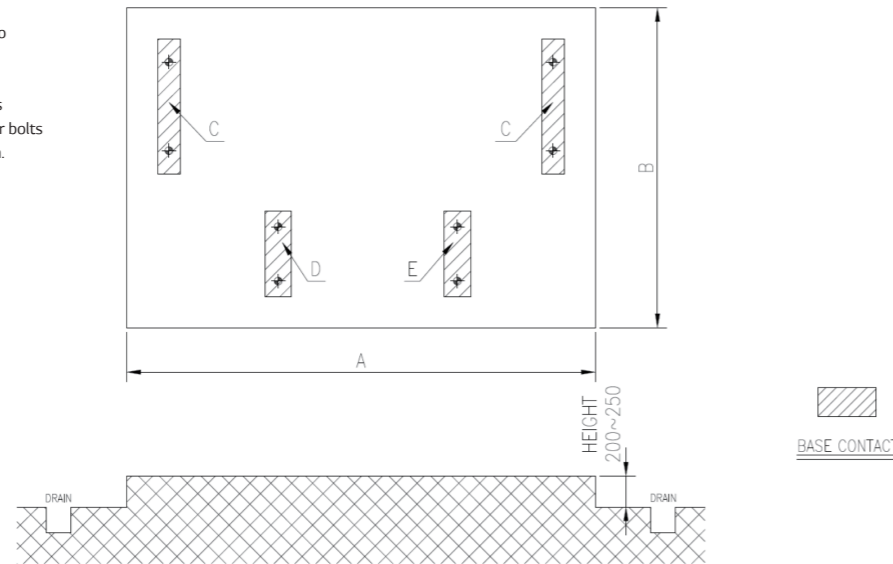

Model	Dimension(mm)		Weight(ton)			
	A	B	C	D	E	Total
WCDN010	2,300	2,000	1.6	0.8	1.0	4.9
WCDN012	2,300	2,100	1.8	0.8	1.0	5.3
WCDN015	3,300	2,100	2.3	0.9	1.1	6.4
WCDN018	3,300	2,100	2.5	1.0	1.2	7.0
WCDN021	3,300	2,150	2.8	1.2	1.4	8.1
WCDN024	3,300	2,150	3.0	1.2	1.4	8.6
WCDN028	4,500	2,250	3.8	1.2	1.4	10.2
WCDN032	4,500	2,250	4.1	1.3	1.5	11.0
WCDN036	4,500	2,650	4.6	1.6	2.0	12.6
WCDN040	4,500	2,650	4.9	1.7	2.1	13.5
WCDN045	4,500	3,000	5.8	2.0	2.4	15.9
WCDN050	4,500	3,000	6.5	2.1	2.5	17.6
WCDN056	4,500	3,300	7.9	2.7	3.1	21.5
WCDN063	5,500	3,300	9.2	3.0	3.4	24.7
WCDN070	5,550	3,300	10.3	3.5	3.9	27.9
WCDN080	5,500	3,300	12.0	4.4	4.9	33.2
WCDN090	5,500	3,300	12.6	5.2	5.7	36.0
WCDN100	6,000	4,000	13.1	6.1	6.7	39.0
WCDN110	6,000	4,000	13.8	7.0	7.6	42.2
WCDN120	6,000	4,000	14.8	8.2	8.6	46.3
WCDN130	6,000	4,000	16.1	9.2	9.7	51.0
WCDN140	6,600	4,500	17.1	10.1	10.5	54.8
WCDN150	6,600	4,500	18.0	11.2	11.8	59.0

### WCMH

1. All external water piping are to be provided with welded ANSI 150PSIG RF flanges by the customer.
2. Installation and service clearance as follows :  
Longitudinal distance - 1,000mm  
Top - 200mm  
Control panel side - 1,200mm
3. Please refer to the LG Electronics drawings for the piping direction.

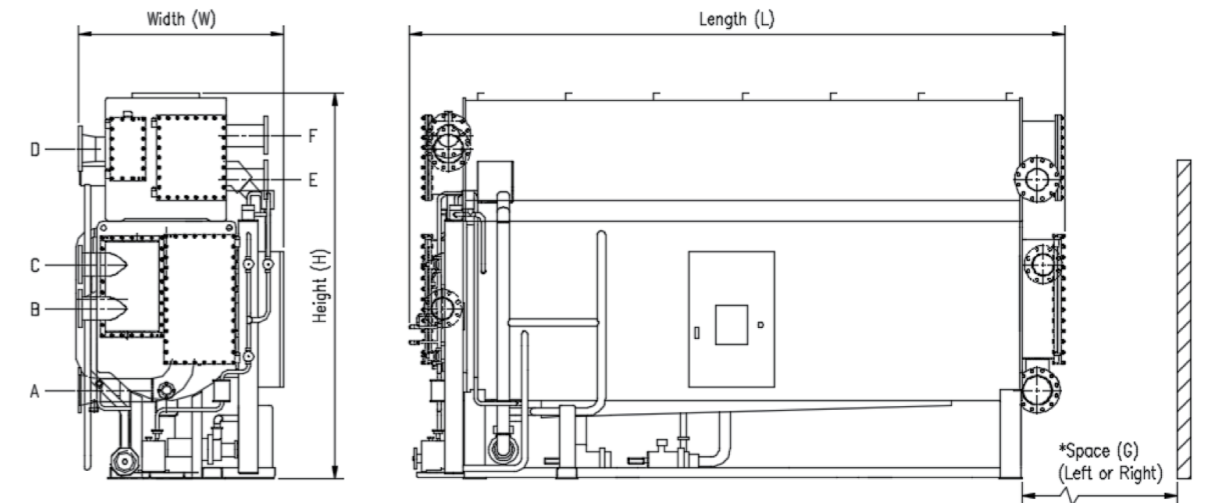
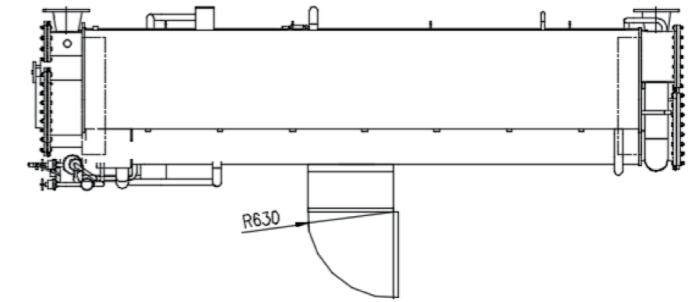

Model	Dimension(mm)			Nozzle Connection(B)						Clearance(mm)
	Length(L)	Width(W)	Height(H)	A	B	C	D	E	F	
WCMH008	2,790	1,600	2,370	4	3	3	4	2	2	2,400
WCMH009	2,790	1,600	2,370	4	3	3	4	2	2	2,400
WCMH011	3,700	1,500	2,370	5	4	4	5	2 1/2	2.5	3,400
WCMH014	3,700	1,500	2,370	5	4	4	5	2 1/2	2.5	3,400
WCMH016	3,850	1,560	2,715	6	5	5	6	3	3	3,400
WCMH018	3,850	1,560	2,715	6	5	5	6	3	3	3,400
WCMH021	4,870	1,560	2,715	8	5	5	8	3	3	4,500
WCMH024	4,870	1,560	2,715	8	5	5	8	3	3	4,500
WCMH027	4,860	1,800	2,970	8	6	6	8	4	4	4,500
WCMH030	4,860	1,800	2,970	8	6	6	8	4	4	4,500
WCMH034	4,940	1,940	3,330	10	6	6	10	4	4	4,500
WCMH038	4,940	1,940	3,330	10	6	6	10	4	4	4,500
WCMH042	4,940	2,045	3,540	10	8	8	10	5	5	4,500
WCMH047	5,480	2,045	3,540	10	8	8	10	5	5	5,200
WCMH053	5,980	2,045	3,540	10	8	8	10	5	5	5,700
WCMH060	5,700	2,340	3,900	12	10	10	12	6	6	5,200
WCMH068	6,200	2,340	3,900	12	10	10	12	6	6	5,700
WCMH075	6,730	2,340	3,900	12	10	10	12	6	6	6,200
WCMH083	6,270	4,200	3,000	14	12	12	14	6	6	5,700
WCMH090	6,795	4,200	3,000	14	12	12	14	6	6	6,200
WCMH098	7,295	4,200	3,000	14	12	12	14	6	6	6,700
WCMH105	6,830	4,410	3,000	16	12	12	16	8	8	6,200
WCMH113	7,330	4,410	3,000	16	12	12	16	8	8	6,700
WCMH120	7,850	4,410	3,000	18	12	12	18	8	8	7,400
WCMH135	8,350	4,410	3,000	18	12	12	18	8	8	8,000



### WCMH

1. The foundation and the floor must be sufficiently strong to support the unit weight.
2. Provide a flow drain near chiller foundation.
3. Only if foundation anchoring is required, anchor bolts, nuts and washers, shall be supplied together with chiller. Anchor bolts must be fixed on the foundation prior to chiller installation.
4. Unit must be leveled before startup.  
(Horizontal level must be below than 2mm/1,000mm)

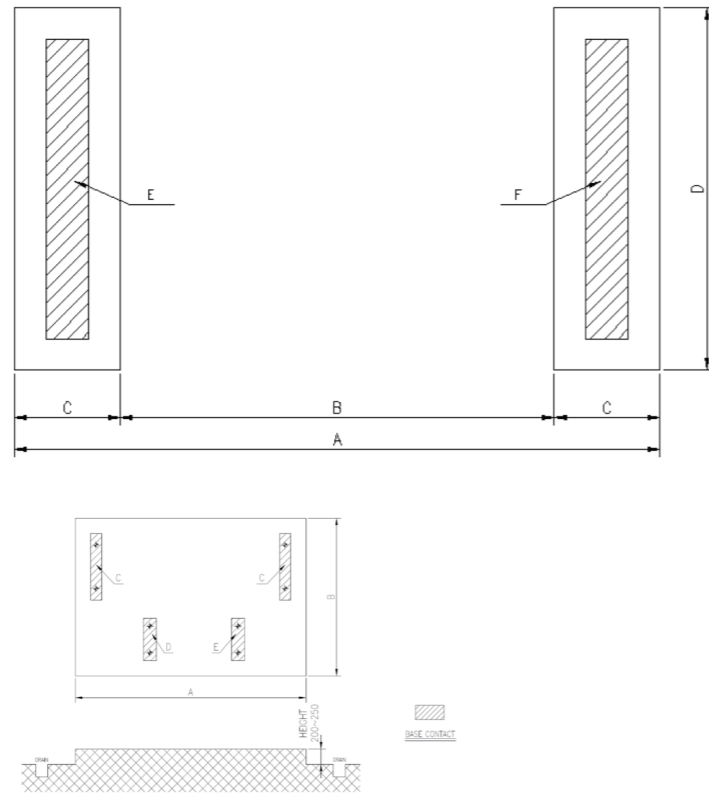

MODEL	Dimension(mm)				Weight(ton)		
	A	B	C	D	E	F	TOTAL
WCMH008	2,465	1,375	545	1,270	2.1	2.1	4.2
WCMH009	2,465	1,375	545	1,270	2.2	2.2	4.4
WCMH011	3,485	2,395	545	1,270	2.6	2.6	5.2
WCMH014	3,485	2,395	545	1,270	2.8	2.8	5.6
WCMH016	3,485	2,345	570	1,520	3.4	3.4	6.8
WCMH018	3,485	2,345	570	1,520	3.6	3.6	7.2
WCMH021	4,505	3,365	570	1,520	4.1	4.1	8.2
WCMH024	4,505	3,365	570	1,520	4.2	4.2	8.4
WCMH027	4,505	3,265	620	1,580	5.5	5.5	11.0
WCMH030	4,505	3,265	620	1,580	5.7	5.7	11.4
WCMH034	4,505	3,265	620	1,680	7.0	7.0	14.0
WCMH038	4,505	3,265	620	1,680	7.2	7.2	14.4
WCMH042	4,505	3,165	670	1,960	8.3	8.3	16.6
WCMH047	5,050	3,710	670	1,960	9.0	9.0	18.0
WCMH053	5,545	4,205	670	1,960	9.6	9.6	19.2
WCMH060	5,050	3,610	720	2,000	13.3	13.3	26.6
WCMH068	5,545	4,105	720	2,000	14.2	14.2	28.4
WCMH075	6,070	4,630	720	2,000	15.5	15.5	31.0
WCMH083	5,145	3,705	720	3,720	16.6	16.6	33.2
WCMH090	5,670	4,230	720	3,720	18.0	18.0	36.0
WCMH098	6,170	4,730	720	3,720	19.5	19.5	39.0
WCMH105	5,670	4,230	720	4,230	21.2	21.2	42.4
WCMH113	6,170	4,730	720	4,230	22.2	22.2	44.4
WCMH120	6,690	5,250	720	4,230	23.9	23.9	47.8
WCMH135	7,170	5,730	720	4,230	25.8	25.8	51.6

### WC2H / WC2N

1. All external water piping are to be provided with welded ANSI 150PSIG RF flanges by the customer.
2. Installation and service clearance as follows :  
Longitudinal distance - 1,000mm  
Top - 200mm  
Control panel side - 1,200mm
3. Please refer to the LG Electronics drawings for the piping direction.

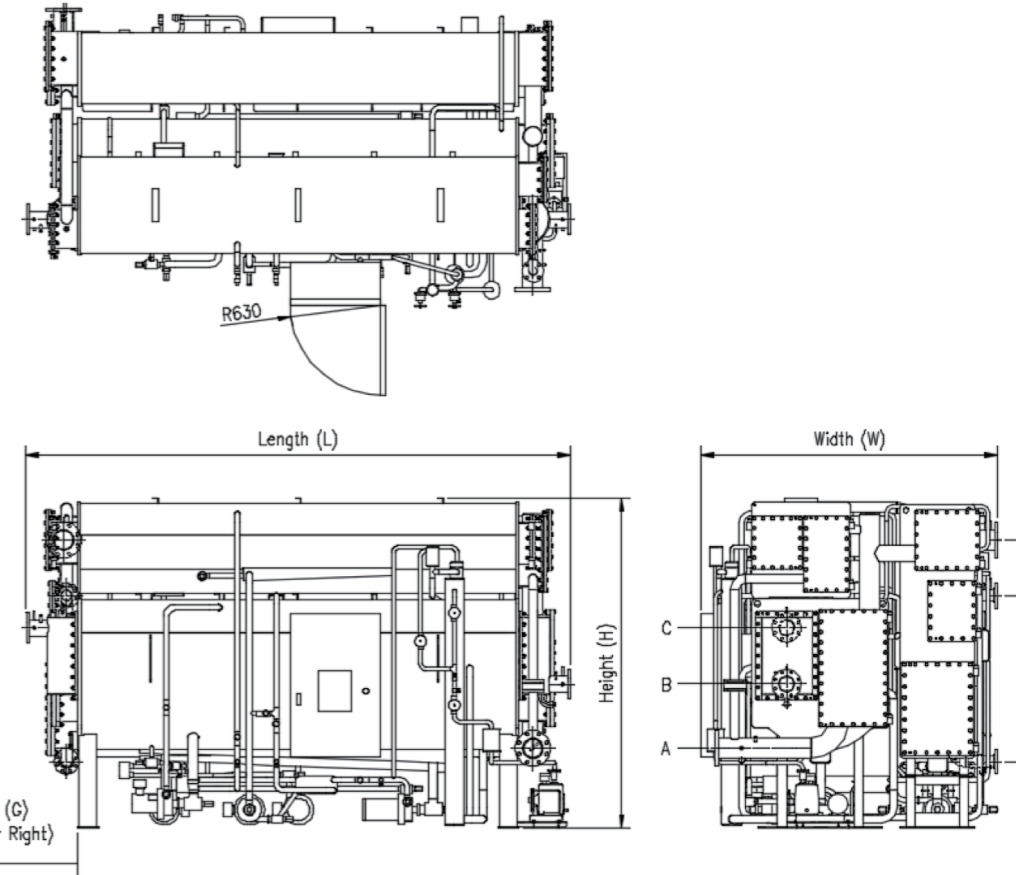

Model	Dimension(mm)			Nozzle Connection(B)						Clearance(mm)
	Length(L)	Width(W)	Height(H)	A	B	C	D	E	F	
WC2H/WC2N008	2,790	2,180	2,310	4	3	3	2	2	4	2,400
WC2H/WC2N009	2,790	2,180	2,310	4	3	3	2	2	4	2,400
WC2H/WC2N011	3,810	2,090	2,310	5	4	4	2 1/2	2 1/2	5	3,400
WC2H/WC2N014	3,810	2,090	2,310	5	4	4	2 1/2	2 1/2	5	3,400
WC2H/WC2N016	3,850	2,210	2,675	6	5	5	3	3	6	3,400
WC2H/WC2N018	3,850	2,210	2,675	6	5	5	3	3	6	3,400
WC2H/WC2N021	4,840	2,210	2,675	8	5	5	3	3	8	4,500
WC2H/WC2N024	4,840	2,210	2,675	8	5	5	3	3	8	4,500
WC2H/WC2N027	4,840	2,500	2,770	8	6	6	4	4	8	4,500
WC2H/WC2N030	4,840	2,500	2,770	8	6	6	4	4	8	4,500
WC2H/WC2N034	4,930	2,710	3,120	10	8	8	4	4	10	4,500
WC2H/WC2N038	4,930	2,710	3,120	10	8	8	4	4	10	4,500
WC2H/WC2N042	4,955	2,940	3,370	10	8	8	4	4	10	4,500
WC2H/WC2N047	5,500	2,940	3,370	10	8	8	4	4	10	5,200
WC2H/WC2N053	6,000	2,940	3,370	10	8	8	4	4	10	5,700
WC2H/WC2N060	5,680	3,400	3,725	12	10	10	5	5	12	5,200
WC2H/WC2N068	6,180	3,400	3,725	12	10	10	5	5	12	5,700
WC2H/WC2N075	6,700	3,400	3,725	12	10	10	5	5	12	6,200
WC2H/WC2N083	6,270	4,070	3,890	14	12	12	5	5	14	5,700
WC2H/WC2N090	6,795	4,070	3,890	14	12	12	5	5	14	6,200
WC2H/WC2N098	7,295	4,070	3,890	14	12	12	5	5	14	6,700
WC2H/WC2N105	6,820	4,500	4,080	16	12	12	6	6	16	6,200
WC2H/WC2N113	7,320	4,500	4,080	16	12	12	6	6	16	6,700
WC2H/WC2N120	7,840	4,500	4,080	16	12	14	6	6	18	7,400
WC2H/WC2N135	8,320	4,500	4,080	16	12	14	6	6	18	8,000

### WC2H / WC2N

1. The foundation and the floor must be sufficiently strong to support the unit weight.
2. Provide a flow drain near chiller foundation.
3. Only if foundation anchoring is required, anchor bolts, nuts and washers, shall be supplied together with chiller. Anchor bolts must be fixed on the foundation prior to chiller installation.
4. Unit must be leveled before startup.  
(Horizontal level must be below than 2mm/1,000mm)

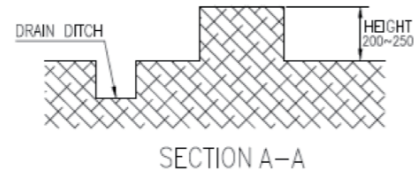
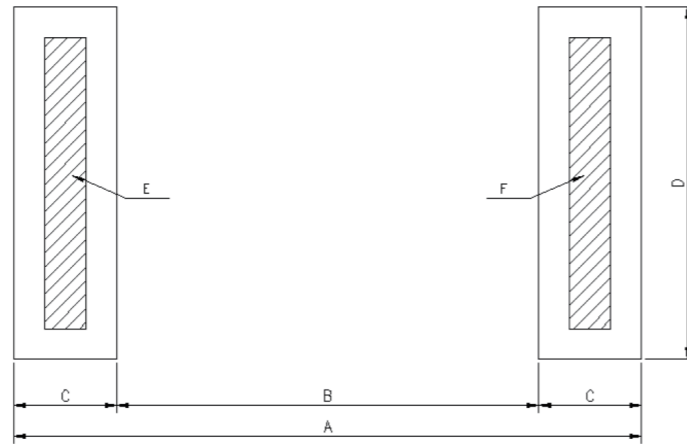

MODEL	Dimension(mm)				Weight(ton)		
	A	B	C	D	E	F	TOTAL
WC2H/WC2N008	2,465	1,375	545	1,960	2.8	2.8	5.6
WC2H/WC2N009	2,465	1,375	545	1,960	2.9	2.9	5.8
WC2H/WC2N011	3,485	2,395	545	1,960	3.5	3.5	7.0
WC2H/WC2N014	3,485	2,395	545	1,960	3.7	3.7	7.4
WC2H/WC2N016	3,485	2,345	570	2,080	4.7	4.7	9.4
WC2H/WC2N018	3,485	2,345	570	2,080	4.9	4.9	9.8
WC2H/WC2N021	4,505	3,365	570	2,080	5.6	5.6	11.2
WC2H/WC2N024	4,505	3,365	570	2,080	5.9	5.9	11.8
WC2H/WC2N027	4,505	3,265	620	2,350	7.1	7.1	14.2
WC2H/WC2N030	4,505	3,265	620	2,350	7.4	7.4	14.8
WC2H/WC2N034	4,505	3,265	620	2,540	9.2	9.2	18.4
WC2H/WC2N038	4,505	3,265	620	2,540	9.6	9.6	19.2
WC2H/WC2N042	4,505	3,165	670	2,790	11.4	11.4	22.8
WC2H/WC2N047	5,050	3,710	670	2,790	12.4	12.4	24.8
WC2H/WC2N053	5,545	4,205	670	2,790	13.5	13.5	27.0
WC2H/WC2N060	5,050	3,610	720	3,200	16.8	16.8	33.6
WC2H/WC2N068	5,545	4,105	720	3,200	18.0	18.0	36.0
WC2H/WC2N075	6,070	4,630	720	3,200	19.6	19.6	39.2
WC2H/WC2N083	5,145	3,705	720	3,720	21.6	21.6	43.2
WC2H/WC2N090	5,670	4,230	720	3,720	23.6	23.6	47.2
WC2H/WC2N098	6,170	4,730	720	3,720	25.6	25.6	51.2
WC2H/WC2N105	5,670	4,230	720	4,230	27.6	27.6	55.2
WC2H/WC2N113	6,170	4,730	720	4,230	29.9	29.9	59.8
WC2H/WC2N120	6,690	5,250	720	4,230	32.4	32.4	64.8
WC2H/WC2N135	7,170	5,730	720	4,230	33.8	33.8	67.6

### WCSH

1. All external water piping are to be provided with welded ANSI 150PSIG RF flanges by the customer.
2. Installation and service clearance as follows :  
Longitudinal distance - 1,000mm  
Top - 200mm  
Control panel side - 1,200mm
3. Please refer to the LG Electronics drawings for the piping direction.

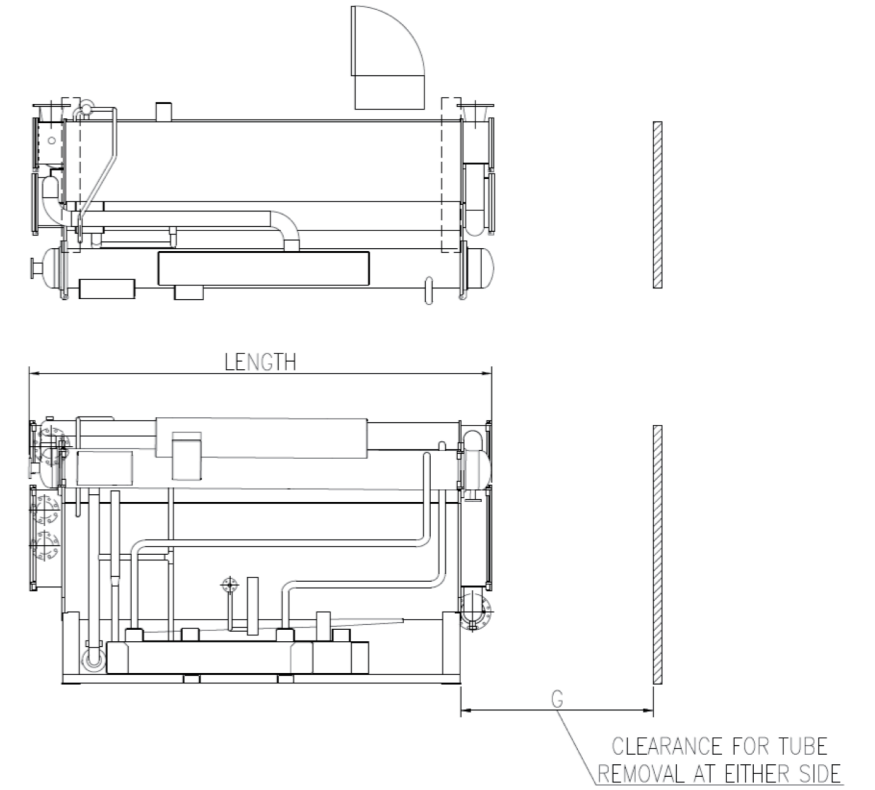
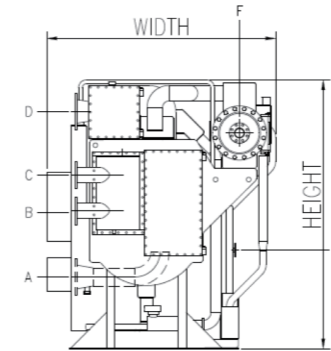

Model	Dimension(mm)			Nozzle Connection(B)						Clearance(mm)
	Length	Width	Height	A	B	C	D	E	F	
WCSH010	2,750	1,930	2,065	5	4	4	5	1	2	2,400
WCSH012	2,750	1,930	2,065	5	4	4	5	1	2	2,400
WCSH015	3,720	1,930	2,070	5	4	4	5	1	2	3,400
WCSH018	3,720	1,930	2,110	5	4	4	5	1	2	3,400
WCSH021	3,720	2,000	2,415	6	5	5	6	1	2	3,400
WCSH024	3,720	2,000	2,415	6	5	5	6	1	2	3,400
WCSH028	4,740	2,070	2,415	8	6	6	8	1	2 1/2	4,500
WCSH032	4,740	2,070	2,415	8	6	6	8	1	2 1/2	4,500
WCSH036	4,800	2,200	2,590	8	6	6	8	1 1/2	2	4,500
WCSH040	4,800	2,200	2,590	8	6	6	8	1 1/2	2	4,500
WCSH045	4,830	2,445	2,950	10	8	8	10	1 1/2	2	4,500
WCSH050	4,830	2,445	2,950	10	8	8	10	1 1/2	2	4,500
WCSH056	4,985	2,610	3,300	12	8	8	12	2	4	4,500
WCSH063	5,485	2,610	3,300	12	8	8	12	2	4	5,200
WCSH070	5,985	2,610	3,300	12	8	8	12	2	4	5,700

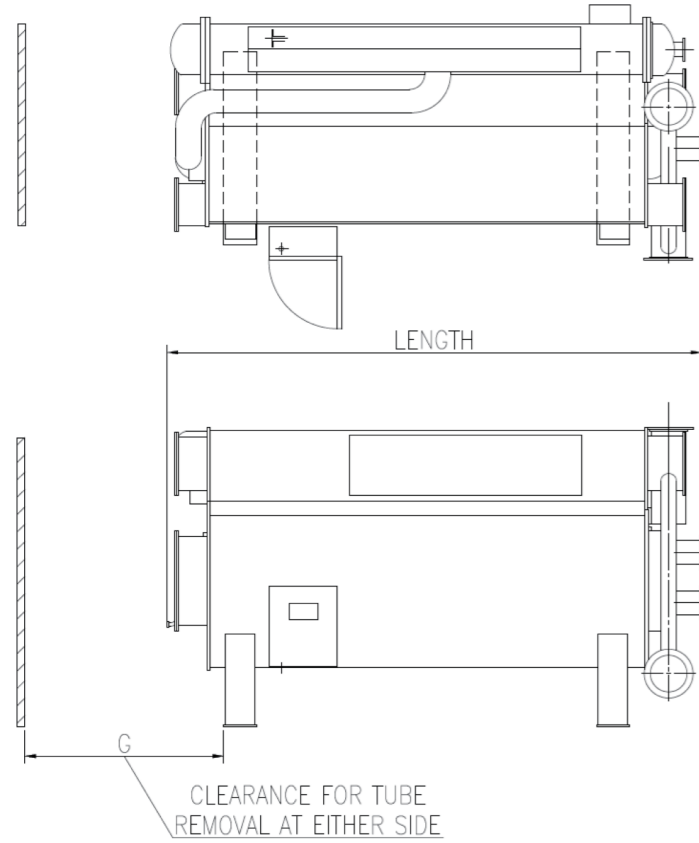

### WCSH

- All external water piping are to be provided with welded ANSI 150PSIG RF flanges by the customer.
- Installation and service clearance as follows :  
 Longitudinal distance - 1,000mm  
 Top - 200mm  
 Control panel side - 1,200mm
- Please refer to the LG Electronics drawings for the piping direction.

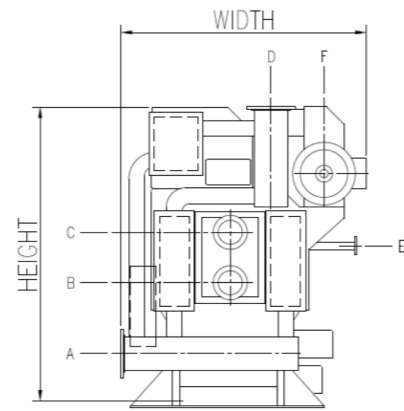

Model	Dimension(mm)			Nozzle Connection(B)						Clearance(mm)
	Length	Width	Height	A	B	C	D	E	F	
WCSH080	5,635	3,090	3,550	14	10	10	14	2 1/2	5	5,200
WCSH090	6,130	3,090	3,550	14	10	10	14	2 1/2	5	5,700
WCSH100	6,590	3,090	3,550	14	10	10	14	2 1/2	5	6,200
WCSH110	6,140	3,180	3,820	16	12	12	16	3	6	5,700
WCSH120	6,660	3,180	3,820	16	12	12	16	3	6	6,200
WCSH130	7,160	3,180	3,820	16	12	12	16	3	6	6,700
WCSH140	6,860	3,520	3,840	16	14	14	16	3	6	6,200
WCSH150	7,360	3,520	3,840	16	14	14	16	3	6	6,700

### WCSH

- The foundation and the floor must be sufficiently strong to support the unit weight.
- Provide a flow drain near chiller foundation.
- Only if foundation anchoring is required, anchor bolts, nuts and washers, shall be supplied together with chiller. Anchor bolts must be fixed on the foundation prior to chiller installation.
- Unit must be leveled before startup.  
(Horizontal level must be below than 2mm/1,000mm)

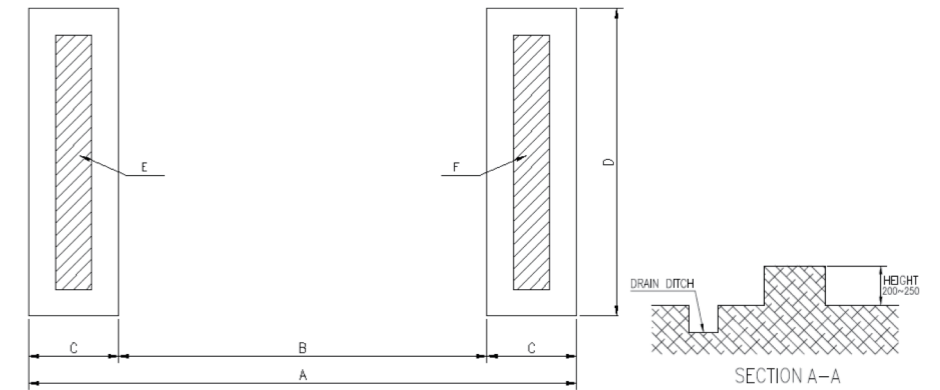

Model	Dimension(mm)				Weight(ton)		
	A	B	C	D	E	F	Total
WCSH010	2,466	1,326	570	1,500	2.3	2.2	4.5
WCSH012	2,466	1,326	570	1,500	2.5	2.4	4.9
WCSH015	3,486	2,346	570	1,500	2.9	2.9	5.8
WCSH018	3,486	2,346	570	1,500	3.2	3.2	6.4
WCSH021	3,486	2,346	570	1,800	3.9	3.8	7.7
WCSH024	3,486	2,346	570	1,800	4.1	4.0	8.1
WCSH028	4,506	3,366	570	1,800	4.7	4.8	9.5
WCSH032	4,506	3,366	570	1,800	4.9	4.9	9.8
WCSH036	4,506	3,166	670	1,900	6.0	5.9	11.9
WCSH040	4,506	3,166	670	1,900	6.5	6.5	13.0
WCSH045	4,506	3,166	670	2,000	7.2	7.1	14.3
WCSH050	4,506	3,166	670	2,000	8.3	8.2	16.5
WCSH056	4,506	3,166	670	2,300	10.2	10.2	20.4
WCSH063	5,048	3,708	670	2,300	10.9	10.8	21.7
WCSH070	5,546	4,206	670	2,300	12.6	12.5	25.1
WCSH080	5,048	3,608	720	2,660	14.7	14.7	29.4
WCSH090	5,546	4,106	720	2,660	15.9	15.8	31.7
WCSH100	6,071	4,631	720	2,660	17.7	17.7	35.4
WCSH110	5,546	4,106	720	2,780	20.3	20.2	40.5
WCSH120	6,071	4,631	720	2,780	22.4	22.4	44.8
WCSH130	6,571	5,131	720	2,780	24.4	24.4	48.8
WCSH140	6,071	4,631	720	3,020	27.3	27.3	54.6
WCSH150	6,571	5,131	720	3,020	29.3	29.3	58.6

### WCPX - Steam

- All external water piping are to be provided with welded ANSI 150PSIG RF flanges by the customer.
- Installation and service clearance as follows :  
 Longitudinal distance - 1,000mm  
 Top - 200mm  
 Control panel side - 1,200mm
- Please refer to the LG Electronics drawings for the piping direction.

- A : Hot Water Inlet
- B : Waste Heat Source Input
- C : Waste Heat Source Output
- D : Hot Water Outlet
- F : Clearance

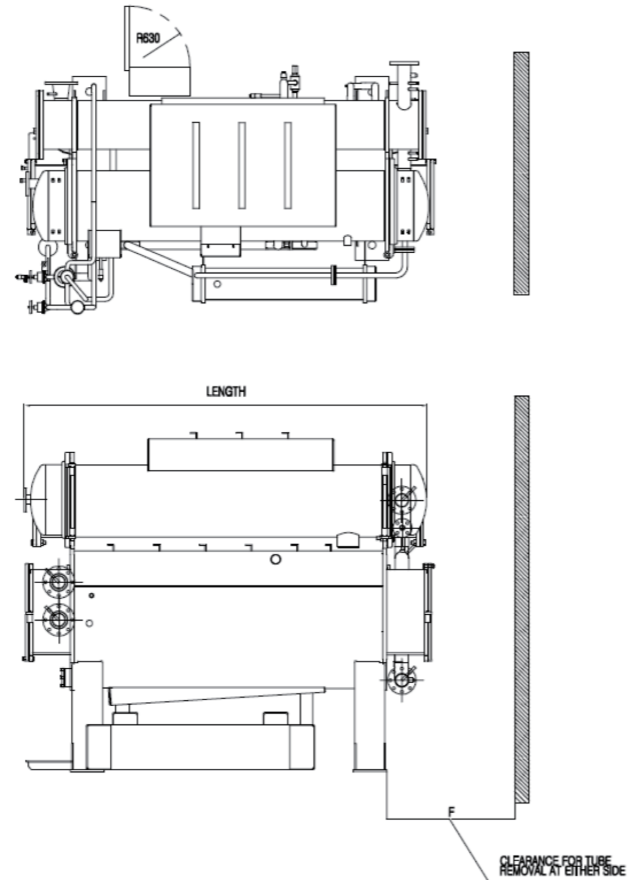
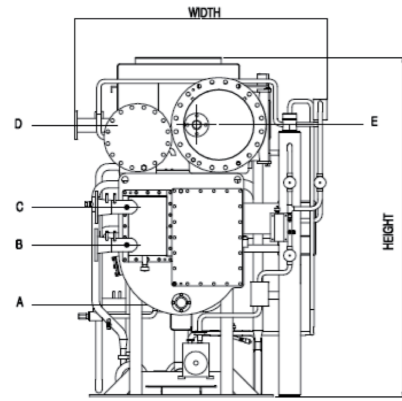

Model	Hot Water Capacity 10 <sup>4</sup> kcal/h	Dimension(mm)			Nozzle Connection(B)					Clearance(mm) F(mm)
		Length	Width	Height	A	B	C	D	E	
WCPX003	30	2,180	1,400	2,090	1.5	2.5	2.5	1.5	1.5	2,000
WCPX007	70	2,680	1,460	2,210	2.5	4	4	2.5	2	2,400
WCPX010	100	2,680	1,460	2,210	2.5	4	4	2.5	2.5	2,400
WCPX015	150	3,700	1,460	2,350	2.5	4	4	2.5	2.5	3,400
WCPX020	200	3,760	1,630	2,600	3	5	5	3	3	3,400
WCPX026	260	4,780	1,630	2,600	4	6	6	4	4	4,500
WCPX033	330	4,880	1,680	2,960	4	6	6	4	4	4,500
WCPX040	400	4,880	1,810	3,270	5	8	8	5	5	4,500
WCPX052	520	5,630	2,120	3,800	5	8	8	5	6	5,200
WCPX066	660	5,740	2,300	4,000	6	10	10	6	8	5,200
WCPX082	820	6,760	2,300	4,000	6	10	10	6	8	6,200

### WCPX - Steam

- All external water piping are to be provided with welded ANSI 150PSIG RF flanges by the customer.
- Installation and service clearance as follows :  
 Longitudinal distance - 1,000mm  
 Top - 200mm  
 Control panel side - 1,200mm
- Please refer to the LG Electronics drawings for the piping direction.

- A : Hot Water Inlet
- B : Waste Heat Source Input
- C : Waste Heat Source Output
- D : Hot Water Outlet
- F : Clearance

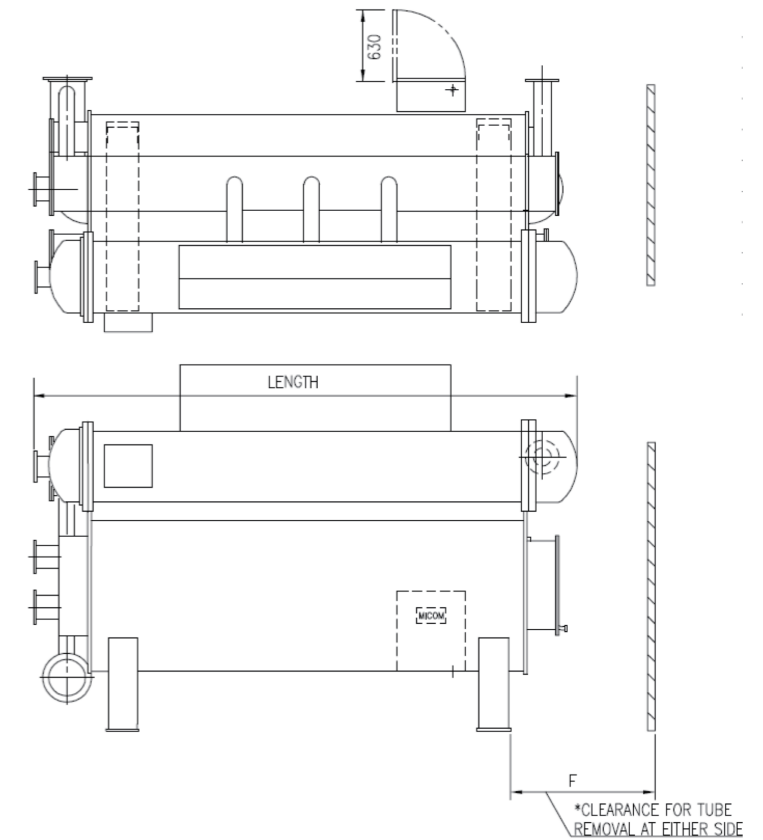
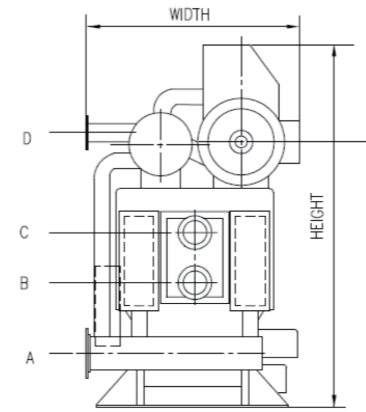

Model	Hot Water Capacity 10 <sup>4</sup> kcal/h	Dimension(mm)			Nozzle Connection(B)					Clearance(mm) F
		Length	Width	Height	A	B	C	D	E	
WCPX098	980	6,720	2,780	4,200	8	12	12	8	8	6,200
WCPX115	1,150	6,860	3,010	4,300	8	14	14	8	10	6,200
WCPX130	1,300	7,370	3,240	4,400	10	16	16	10	10	6,800
WCPX147	1,470	8,170	3,240	4,400	10	16	16	10	10	7,600
WCPX163	1,630	8,970	3,240	4,400	10	16	16	10	10	8,400

### WCPX - Steam

- All external water piping are to be provided with welded ANSI 150PSIG RF flanges by the customer.
- Installation and service clearance as follows :  
 Longitudinal distance - 1,000mm  
 Top - 200mm  
 Control panel side - 1,200mm
- Please refer to the LG Electronics drawings for the piping direction.

- A : Hot Water Inlet
- B : Waste Heat Source Input
- C : Waste Heat Source Output
- D : Hot Water Outlet
- F : Clearance

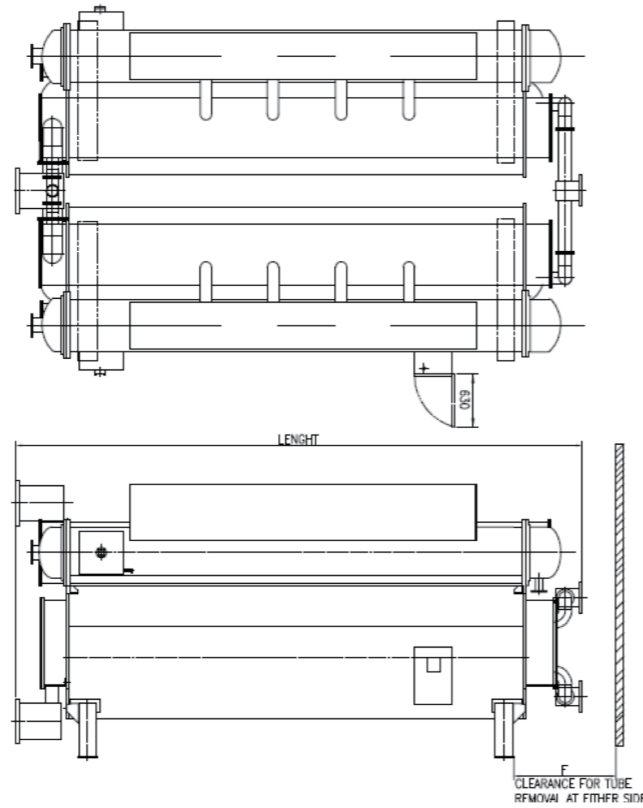
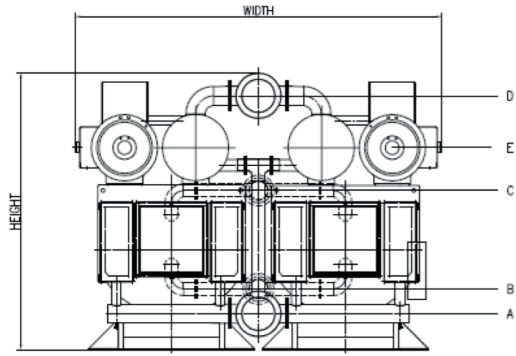

Model	Hot Water Capacity 10 <sup>4</sup> kcal/h	Dimension(mm)			Nozzle connection(B)					Clearance (mm)
		Length	Width	Height	A	B	C	D	E	
WCPX196	1,960	6,720	5,460	4,300	12	16	16	12	8 x 2	6,200
WCPX230	2,300	6,860	5,920	4,400	14	18	18	14	10 x 2	6,200
WCPX260	2,600	7,370	6,380	4,400	14	20	20	14	10 x 2	6,800

### WCPX003-WCPX163

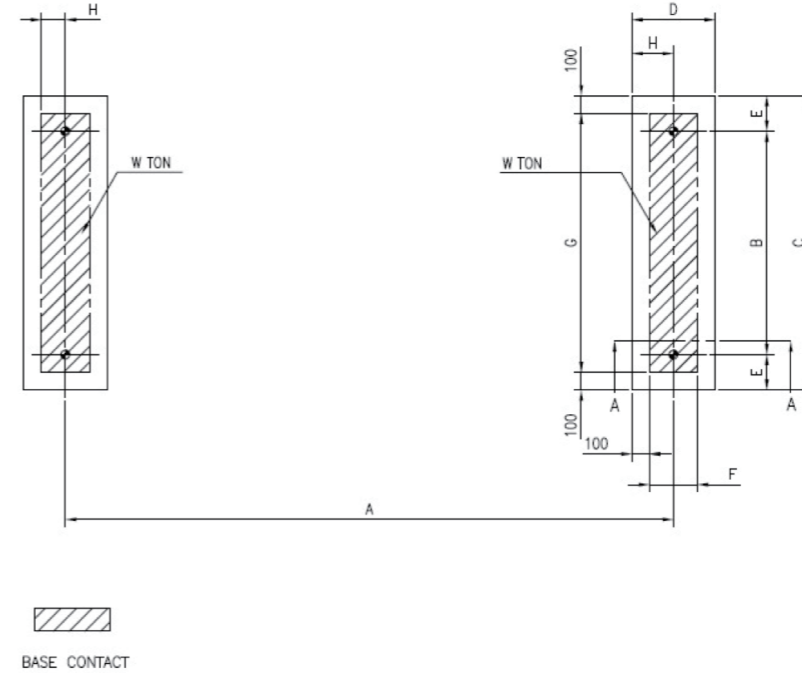

- NOTE.
- ◆ INDICATES THE POSITION OF ANCHOR BOLTS.
  - THE FOUNDATION AND THE FLOOR MUST BE SUFFICIENTLY STRONG TO SUPPORT THE UNIT WEIGHT.
  - PROVIDE A FLOOR DRAIN NEAR CHILLER FOUNDATION.
  - ONLY IF FOUNDATION ANCHORING IS REQUIRED, ANCHOR BOLTS, NUTS AND WASHERS, SHALL BE SUPPLIED TOGETHER WITH CHILLER. ANCHOR BOLTS MUST BE FIXED ON THE FOUNDATION PRIOR TO CHILLER INSTALLATION.
  - UNIT MUST BE LEVELED BEFORE STARTUP.  
(HORIZONTAL LEVEL MUST BE BELOW THAN 2mm/1000mm)

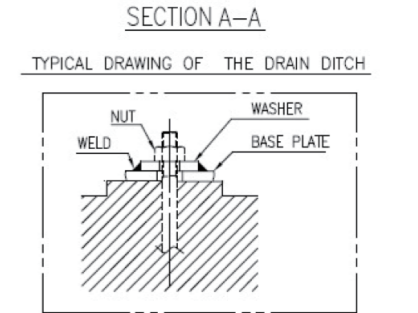
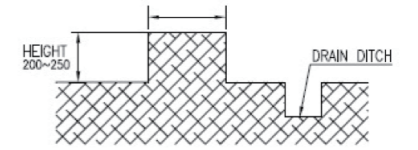

Model	Hot Water Capacity 10 <sup>4</sup> kcal/h	Dimension(mm)								
		A	B	C	D	E	F	G	H	W(ton)
WCPX003	30	1,470	820	1,140	295	160	95	940	147.5	1.5
WCPX007	70	1,926	820	1,220	345	200	145	1,020	172.5	2.3
WCPX010	100	1,926	820	1,220	345	200	145	1,020	172.5	2.5
WCPX015	150	2,946	820	1,220	345	200	145	1,020	172.5	3.2
WCPX020	200	2,816	980	1,380	470	200	270	1,180	235	4.2
WCPX026	260	3,836	980	1,380	470	200	270	1,180	235	5.2
WCPX033	330	3,836	1,040	1,440	470	200	270	1,240	235	6.5
WCPX040	400	3,836	1,160	1,560	470	200	270	1,360	235	8.0
WCPX052	520	4,378	1,600	2,000	470	200	270	1,800	235	11.9
WCPX066	660	4,328	1,800	2,200	520	200	320	2,000	260	15.3
WCPX082	820	5,351	1,800	2,200	520	200	320	2,000	260	17.5
WCPX098	980	4,951	2,100	2,500	520	200	320	2,300	260	20.7
WCPX115	1,150	4,951	2,300	2,700	520	200	320	2,500	260	24.1
WCPX130	1,300	5,461	2,500	2,900	520	200	320	2,700	260	27.9
WCPX147	1,470	6,261	2,500	2,900	520	200	320	2,700	260	29.7
WCPX163	1,630	7,061	2,500	2,900	520	200	320	2,700	260	31.5

### WCPX003 - WCPX163

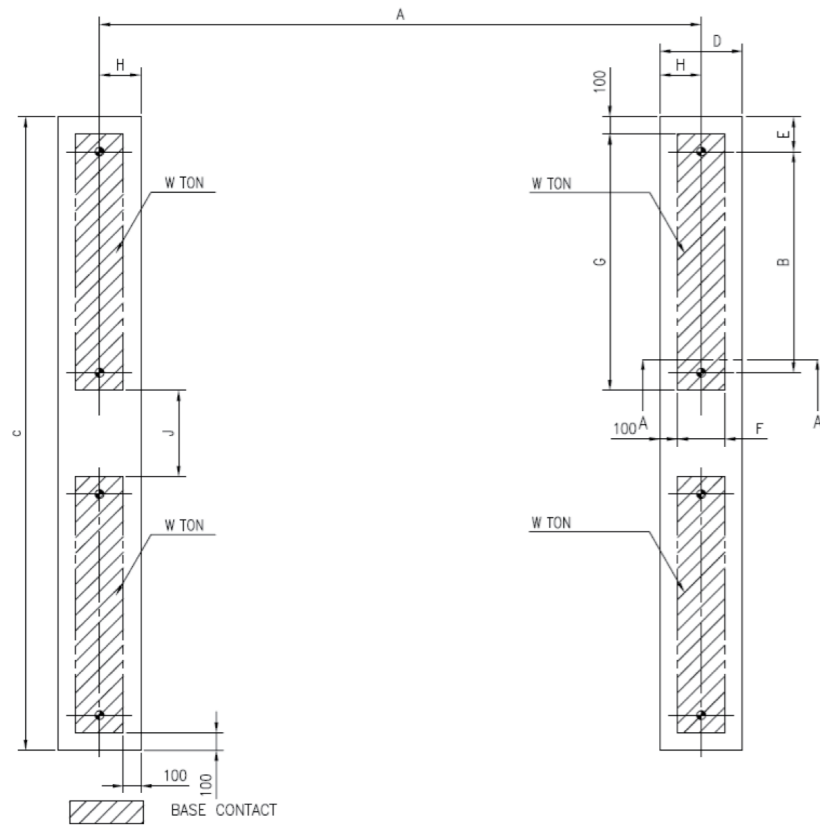

- NOTE:
- ◆ INDICATES THE POSITION OF ANCHOR BOLTS.
  - THE FOUNDATION AND THE FLOOR MUST BE SUFFICIENTLY STRONG TO SUPPORT THE UNIT WEIGHT.
  - PROVIDE A FLOOR DRAIN NEAR CHILLER FOUNDATION.
  - ONLY IF FOUNDATION ANCHORING IS REQUIRED, ANCHOR BOLTS, NUTS AND WASHERS, SHALL BE SUPPLIED TOGETHER WITH CHILLER. ANCHOR BOLTS MUST BE FIXED ON THE FOUNDATION PRIOR TO CHILLER INSTALLATION.
  - UNIT MUST BE LEVELED BEFORE STARTUP. (HORIZONTAL LEVEL MUST BE BELOW THAN 2mm/1000mm)

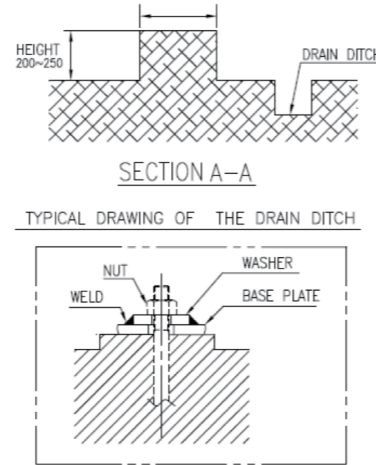

### WCPX - Direct Fired

- All external water piping are to be provided with welded ANSI 150PSIG RF flanges by the customer.
- Installation and service clearance as follows :  
 Longitudinal distance - 1,000mm  
 Top - 200mm  
 Control panel side - 1,200mm
- Please refer to the LG Electronics drawings for the piping direction.

- A : Hot Water Inlet
- B : Waste Heat Source Input
- C : Waste Heat Source Output
- D : Hot Water Outlet
- F : Clearance

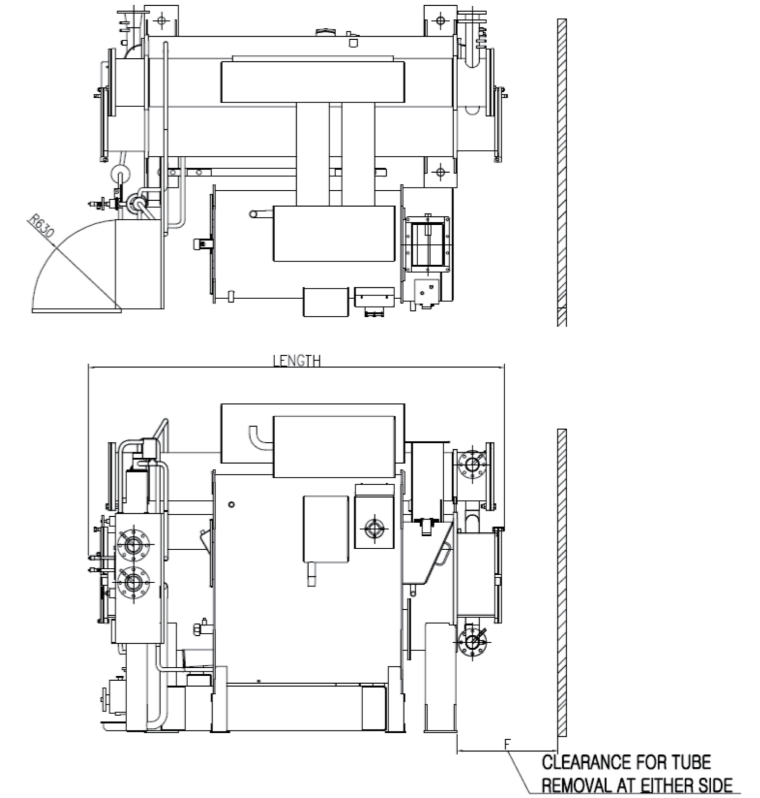
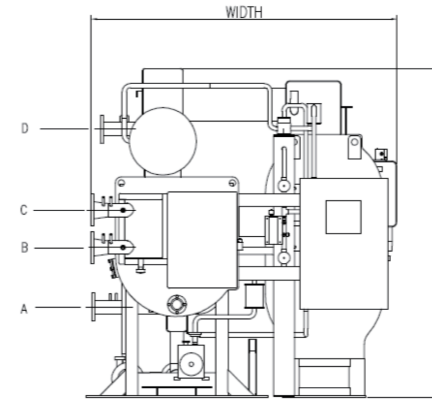

Model	Hot Water Capacity 10 <sup>4</sup> kcal/h	Dimension(mm)									
		A	B	C	D	E	F	G	H	J	W(ton)
WCPX196	1,960	4,951	2,100	5,000	520	200	320	2,300	260	200	41.2
WCPX230	2,300	4,951	2,300	5,400	520	200	320	2,500	260	200	43.3
WCPX260	2,600	5,461	2,500	5,800	520	200	320	2,700	260	200	56.0

Model	Hot Water Capacity 10 <sup>4</sup> kcal/h	Dimension(mm)			Nozzle Connection(B)				Clearance(mm)
		Length	Width	Height	A	B	C	D	
WCPX003	30	2,620	2,140	2,030	1.5	2.5	2.5	1.5	2,000
WCPX007	70	3,120	2,190	2,060	2.5	4	4	2.5	2,400
WCPX010	100	3,120	2,190	2,060	2.5	4	4	2.5	2,400
WCPX015	150	3,990	2,190	2,120	2.5	4	4	2.5	3,400
WCPX020	200	4,020	2,540	2,390	3	5	5	3	3,400
WCPX026	260	4,820	2,560	2,610	4	6	6	4	4,500
WCPX033	330	4,940	2,830	3,030	4	6	6	4	4,500
WCPX040	400	5,080	3,010	3,030	5	8	8	5	4,500
WCPX052	520	6,080	3,500	3,650	5	8	8	5	5,200
WCPX066	660	6,710	4,020	3,650	6	10	10	6	5,200
WCPX082	820	7,810	4,070	3,680	6	10	10	6	6,200

### WCPX003-WCPX082

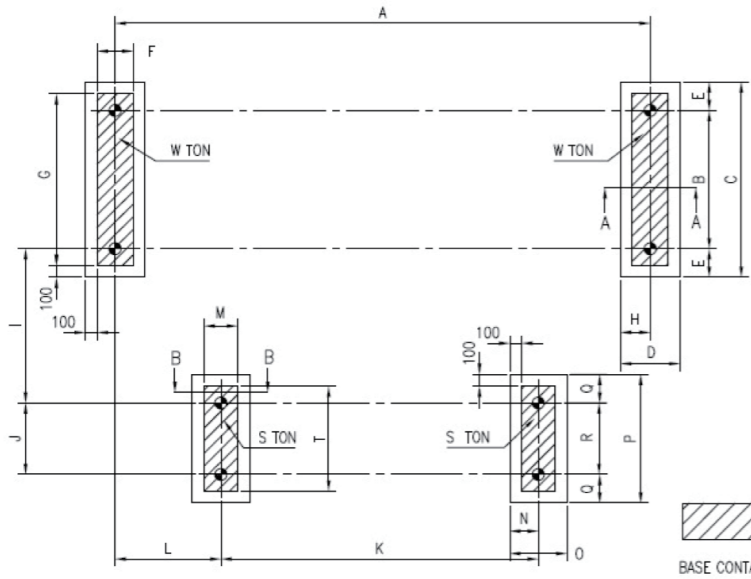

- NOTE.
1. ◆ INDICATES THE POSITION OF ANCHOR BOLTS.
  2. THE FOUNDATION AND THE FLOOR MUST BE SUFFICIENTLY STRONG TO SUPPORT THE UNIT WEIGHT.
  3. PROVIDE A FLOOR DRAIN NEAR CHILLER FOUNDATION.
  4. ONLY IF FOUNDATION ANCHORING IS REQUIRED, ANCHOR BOLTS, NUTS AND WASHERS, SHALL BE SUPPLIED TOGETHER WITH CHILLER. ANCHOR BOLTS MUST BE FIXED ON THE FOUNDATION PRIOR TO CHILLER INSTALLATION.
  5. UNIT MUST BE LEVELED BEFORE STARTUP. (HORIZONTAL LEVEL MUST BE BELOW THAN 2mm/1000mm)

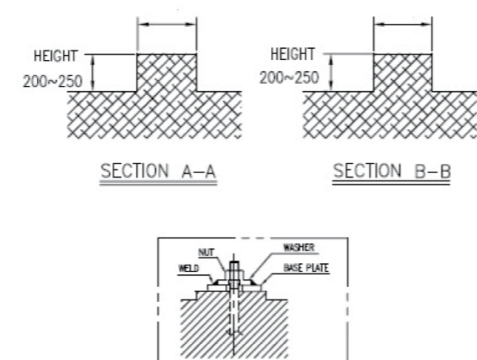

Model	Hot Water Capacity 10 <sup>4</sup> kcal/h	Dimension(mm)																				
		A	B	C	D	E	F	G	H	I	J	K	L	M	N	O	P	Q	R	T	S (Ton)	W (Ton)
WCPX003	30	1,470	820	1,140	295	160	95	940	147.5	258	220	970	698	100	100	200	540	160	220	340	0.8	1.45
WCPX007	70	1,926	820	1,220	345	200	145	1,020	172.5	577	300	1,330	425	130	160	330	750	225	300	440	0.9	1.90
WCPX010	100	1,926	820	1,220	345	200	145	1,020	172.5	547	350	1,350	440	170	185	370	750	200	350	550	0.9	2.10
WCPX015	150	2,946	820	1,220	345	200	145	1,020	172.5	559	350	1,850	672	170	185	370	750	200	350	550	1.3	2.65
WCPX020	200	2,816	980	1,380	470	200	270	1,180	235	549	460	1,954	716	220	210	420	820	185	460	620	1.6	3.45
WCPX026	260	3,836	980	1,380	470	200	270	1,180	235	557	550	2,250	830	220	210	420	920	185	550	720	2.1	4.30
WCPX033	330	3,836	1,040	1,440	470	200	270	1,240	235	480	960	2,250	1,165	200	200	400	1,320	180	960	1,120	2.8	5.35
WCPX040	400	3,836	1,160	1,560	470	200	270	1,360	235	460	1,160	2,400	1,328	300	250	500	1,520	180	1,160	1,320	3.4	6.55
WCPX052	520	4,378	1,600	2,000	470	200	270	1,800	235	460	1,160	3,000	1,328	300	250	500	1,520	180	1,160	1,320	5.0	9.90
WCPX066	660	4,328	1,800	2,200	520	200	320	2,000	260	750	1,260	3,400	0	300	250	500	1,620	180	1,260	1,420	7.0	12.65
WCPX082	820	5,351	1,800	2,200	520	200	320	2,000	260	800	1,340	3,700	0	300	250	500	1,700	180	1,340	1,500	10.5	17.45

### Heating mode(60°C)

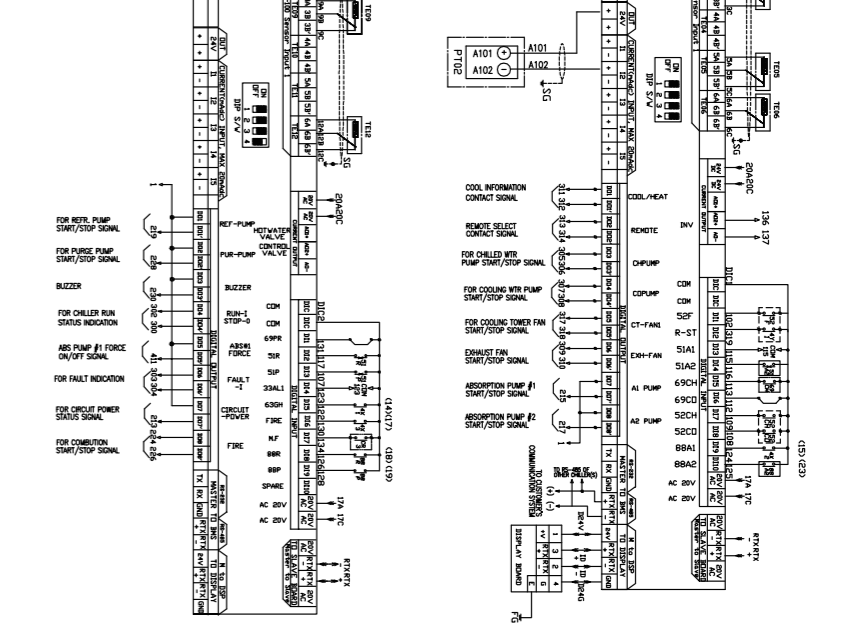
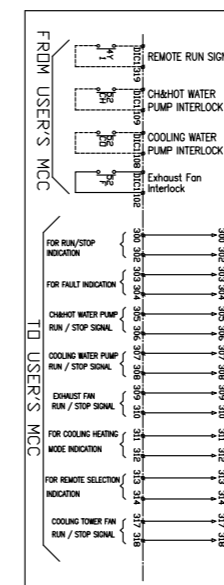
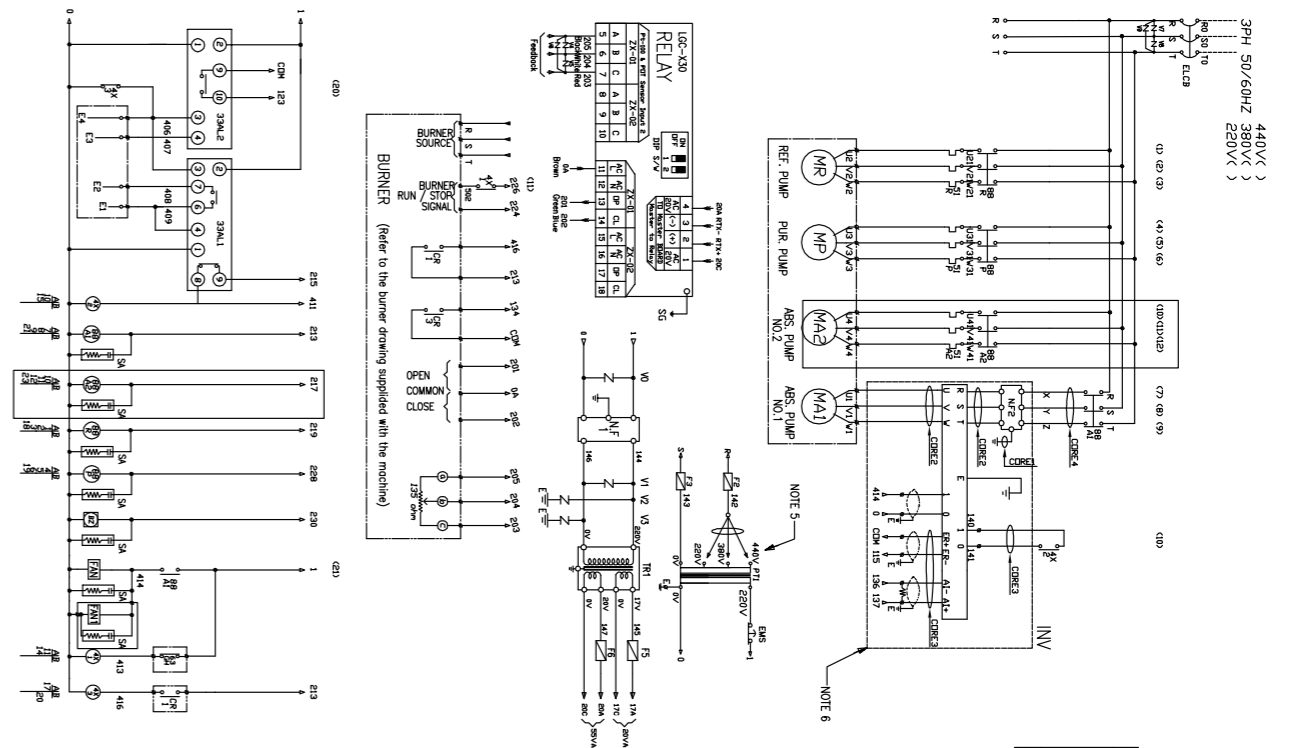

Symbol	DESCRIPTION	Remarks
TE01	On/Off Water Valve Temperature Sensor	PT1000mm
TE02	Hot Water Valve Temperature Sensor	PT1000mm
TE03	Condenser Water Valve Temperature Sensor	PT1000mm
TE04	Condenser Water Temperature Sensor	PT1000mm
TE05	High Condenser Water Temperature Sensor	PT1000mm
TE06	Low Condenser Water Temperature Sensor	PT1000mm
LE12	Exhaust Gas Temperature Sensor	PT1000mm
LE13	Exhaust Gas Temperature Sensor	PT1000mm
LE14	High Generator Level Sensor	PT1000mm
LE15	Low Generator Level Sensor	PT1000mm
LE16	High Generator Level Sensor	PT1000mm
LE17	Low Generator Level Sensor	PT1000mm
LE18	High Generator Level Sensor	PT1000mm
LE19	Low Generator Level Sensor	PT1000mm
LE20	High Generator Level Sensor	PT1000mm
LE21	Low Generator Level Sensor	PT1000mm
LE22	High Generator Level Sensor	PT1000mm
LE23	Low Generator Level Sensor	PT1000mm
LE24	High Generator Level Sensor	PT1000mm
LE25	Low Generator Level Sensor	PT1000mm
LE26	High Generator Level Sensor	PT1000mm
LE27	Low Generator Level Sensor	PT1000mm
LE28	High Generator Level Sensor	PT1000mm
LE29	Low Generator Level Sensor	PT1000mm
LE30	High Generator Level Sensor	PT1000mm
LE31	Low Generator Level Sensor	PT1000mm
LE32	High Generator Level Sensor	PT1000mm
LE33	Low Generator Level Sensor	PT1000mm
LE34	High Generator Level Sensor	PT1000mm
LE35	Low Generator Level Sensor	PT1000mm
LE36	High Generator Level Sensor	PT1000mm
LE37	Low Generator Level Sensor	PT1000mm
LE38	High Generator Level Sensor	PT1000mm
LE39	Low Generator Level Sensor	PT1000mm
LE40	High Generator Level Sensor	PT1000mm
LE41	Low Generator Level Sensor	PT1000mm
LE42	High Generator Level Sensor	PT1000mm
LE43	Low Generator Level Sensor	PT1000mm
LE44	High Generator Level Sensor	PT1000mm
LE45	Low Generator Level Sensor	PT1000mm
LE46	High Generator Level Sensor	PT1000mm
LE47	Low Generator Level Sensor	PT1000mm
LE48	High Generator Level Sensor	PT1000mm
LE49	Low Generator Level Sensor	PT1000mm
LE50	High Generator Level Sensor	PT1000mm
LE51	Low Generator Level Sensor	PT1000mm
LE52	High Generator Level Sensor	PT1000mm
LE53	Low Generator Level Sensor	PT1000mm
LE54	High Generator Level Sensor	PT1000mm
LE55	Low Generator Level Sensor	PT1000mm
LE56	High Generator Level Sensor	PT1000mm
LE57	Low Generator Level Sensor	PT1000mm
LE58	High Generator Level Sensor	PT1000mm
LE59	Low Generator Level Sensor	PT1000mm
LE60	High Generator Level Sensor	PT1000mm
LE61	Low Generator Level Sensor	PT1000mm
LE62	High Generator Level Sensor	PT1000mm
LE63	Low Generator Level Sensor	PT1000mm
LE64	High Generator Level Sensor	PT1000mm
LE65	Low Generator Level Sensor	PT1000mm
LE66	High Generator Level Sensor	PT1000mm
LE67	Low Generator Level Sensor	PT1000mm
LE68	High Generator Level Sensor	PT1000mm
LE69	Low Generator Level Sensor	PT1000mm
LE70	High Generator Level Sensor	PT1000mm
LE71	Low Generator Level Sensor	PT1000mm
LE72	High Generator Level Sensor	PT1000mm
LE73	Low Generator Level Sensor	PT1000mm
LE74	High Generator Level Sensor	PT1000mm
LE75	Low Generator Level Sensor	PT1000mm
LE76	High Generator Level Sensor	PT1000mm
LE77	Low Generator Level Sensor	PT1000mm
LE78	High Generator Level Sensor	PT1000mm
LE79	Low Generator Level Sensor	PT1000mm
LE80	High Generator Level Sensor	PT1000mm
LE81	Low Generator Level Sensor	PT1000mm
LE82	High Generator Level Sensor	PT1000mm
LE83	Low Generator Level Sensor	PT1000mm
LE84	High Generator Level Sensor	PT1000mm
LE85	Low Generator Level Sensor	PT1000mm
LE86	High Generator Level Sensor	PT1000mm
LE87	Low Generator Level Sensor	PT1000mm
LE88	High Generator Level Sensor	PT1000mm
LE89	Low Generator Level Sensor	PT1000mm
LE90	High Generator Level Sensor	PT1000mm
LE91	Low Generator Level Sensor	PT1000mm
LE92	High Generator Level Sensor	PT1000mm
LE93	Low Generator Level Sensor	PT1000mm
LE94	High Generator Level Sensor	PT1000mm
LE95	Low Generator Level Sensor	PT1000mm
LE96	High Generator Level Sensor	PT1000mm
LE97	Low Generator Level Sensor	PT1000mm
LE98	High Generator Level Sensor	PT1000mm
LE99	Low Generator Level Sensor	PT1000mm
LE100	High Generator Level Sensor	PT1000mm





# Interface diagram

Direct fired absorption chiller & heater



# Interface diagram

Steam/Hot water driven absorption chiller

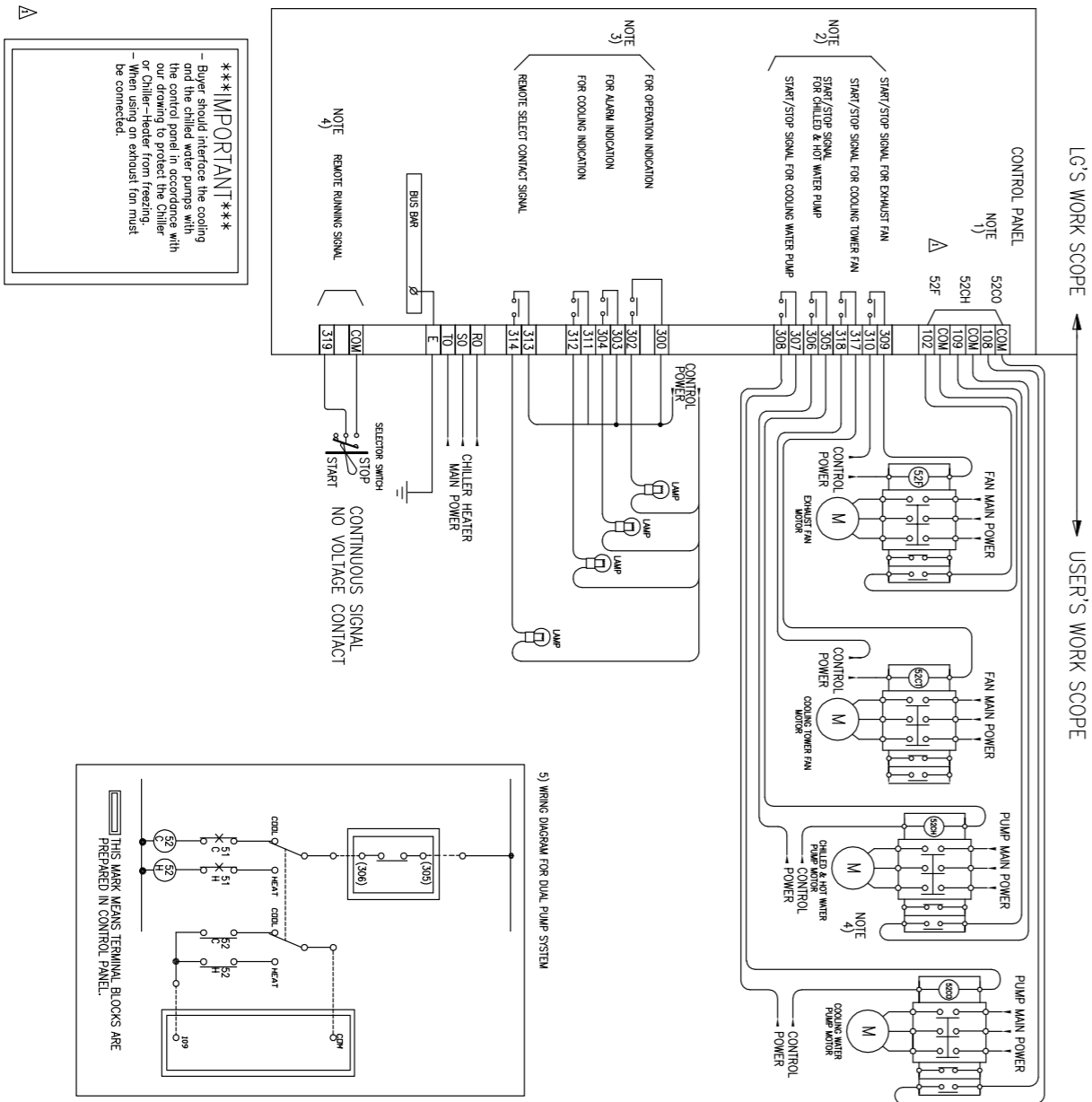

**\*\*\*IMPORTANT\*\*\***  
 - Buyer should interface the cooling and the chilled water pumps with the control panel in accordance with our drawing to protect the Chiller or Chiller-Heater from freezing.  
 - When using an exhaust fan must be connected.

**\*\*\*IMPORTANT\*\*\***  
 Buyer should interface the cooling and the chilled water pumps with the control panel in accordance with our drawing to protect the Chiller or Chiller-Heater from freezing.

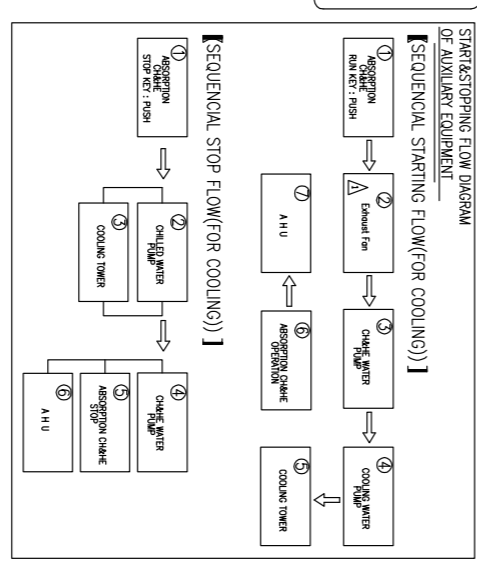
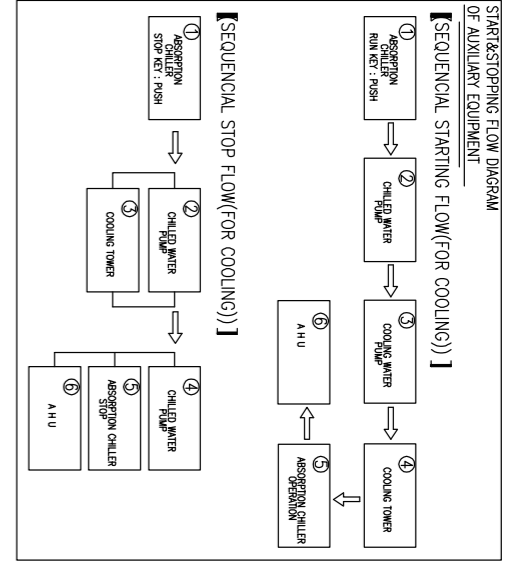
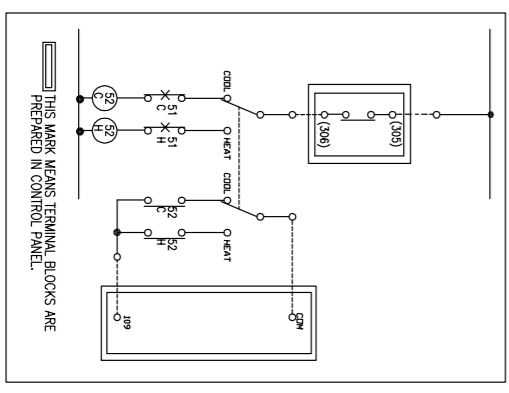
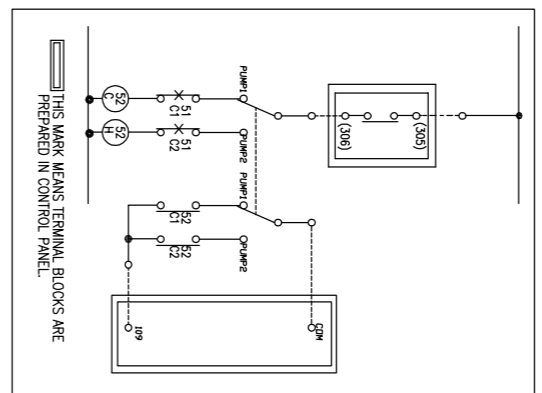
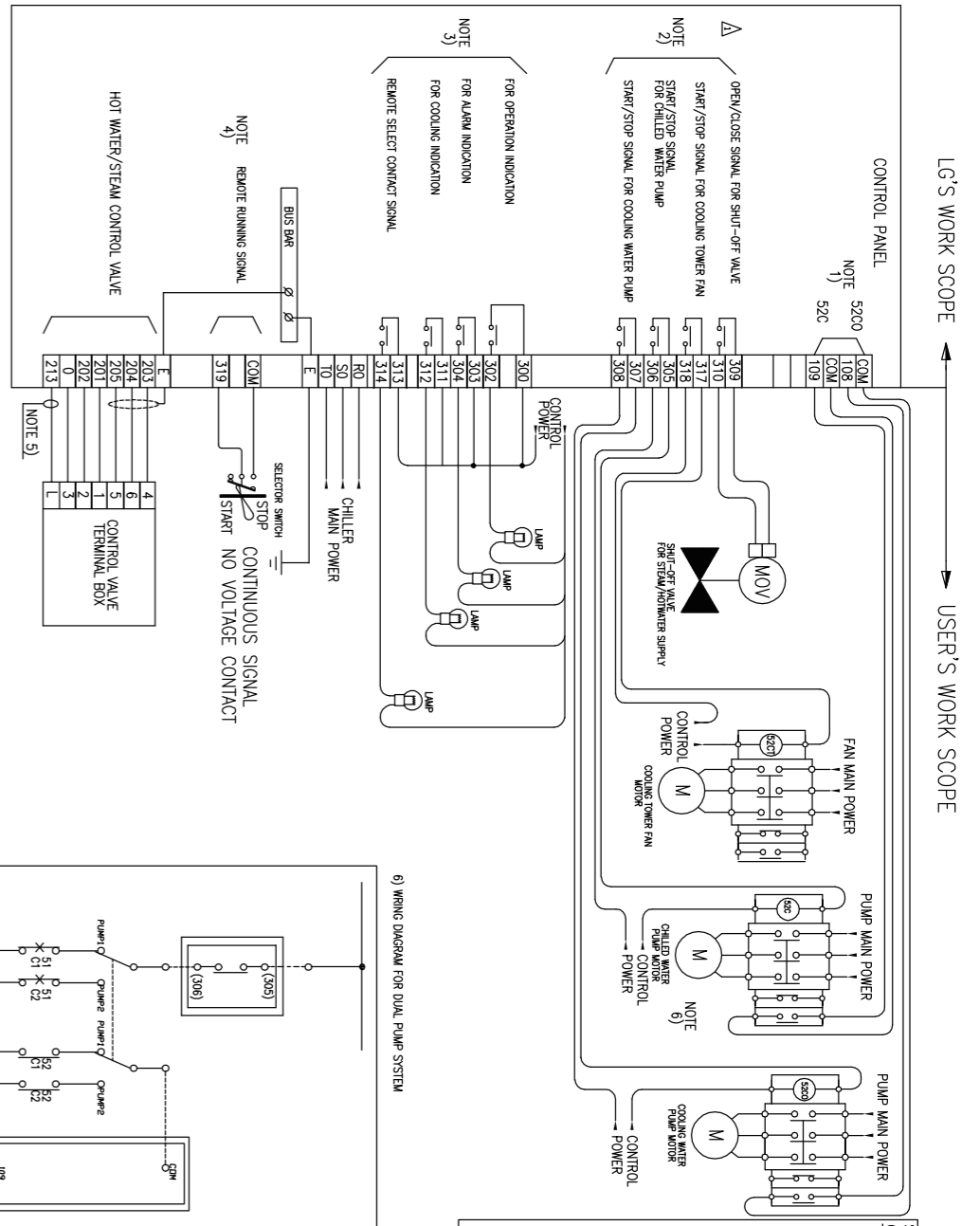

- NOTE**
- 1) THESE INTERLOCK CONTACTS SHALL BE SUPPLIED BY USER.  
 - CONTACT DESCRIPTION : NO-VOLTAGE CONTACT(DRY CONTACT)  
 - ALLOWABLE CONTACT RESISTANCE : MAX. 100ohm  
 - When using an exhaust fan must be connected.
  - 2) THESE CONTACTS ARE FOR STARTING/STOPPING PERIPHERAL EQUIPMENT.  
 - RATED CONTACT : BELOW 250Vdc, 0.1A  
 - RATED CONTACT : BELOW 250Vdc, 0.1A
  - 3) THESE CONTACTS ARE FOR INDICATION OF CHILLER OR CHILLER OPERATION.  
 - RATED CONTACT : BELOW 250Vdc, 0.1A
  - 4) THESE SIGNALS SHALL BE SUPPLIED BY USER.

- NOTE**
- 1) THESE INTERLOCK CONTACTS SHALL BE SUPPLIED BY THE USER.  
 - CONTACT DESCRIPTION : NO-VOLTAGE CONTACT(DRY CONTACT)  
 - ALLOWABLE CONTACT RESISTANCE : MAX. 100ohm
  - 2) THESE CONTACTS ARE FOR STARTING/STOPPING THE PERIPHERAL EQUIPMENT.  
 - RATED CONTACT : BELOW 250Vdc, 0.1A  
 - RATED CONTACT : BELOW 250Vdc, 0.1A
  - 3) THESE CONTACTS ARE FOR INDICATION OF THE CHILLER OPERATION.  
 - RATED CONTACT : BELOW 250Vdc, 0.1A
  - 4) THESE SIGNALS SHALL BE SUPPLIED BY USER.
  - 5) THIS WIRE IS FOR ONLY SPRING RETURN TYPE VALVE.

# Guide specification

## Direct fired absorption Chiller & Heater (WCDH Series)

### Contents

1. Application Scope
2. Equipment Specification
3. Work Scope
4. Supply Scope
5. Warranty and Service
6. Others



# Guide specification



## 1. Application Scope

This manufacturing specification is applied to all models of the absorption chiller-heater H-Series.

## 2. Equipment Specification

### 2.1 General

2.1.1 The absorption chiller-heater H-Series uses the gas fuels such as LNG and city gas or the liquid fuels such as diesel and lamp oil. The microcomputer controls cooling capacity in PID (Proportion, Integration, Differentiation).

2.1.2 Lithium Bromide(LiBr mass concentration 55%) added with anticorrosive agent(Mo type)is used for absorbent, and distilled water(H<sub>2</sub>O)is used for refrigerant.

2.1.3 The steel sheet and pipes are surface treated to prevent corrosion.

2.1.4 To check any leakage of the stored product before transportation and test-run and to prevent air infiltration, nitrogen gas of 0.3 Kg/cm<sup>2</sup>G is filled.

### 2.2 Components

2.2.1 Upper part(Low-temperature Regenerator, Condenser)

2.2.2 Lower part(Evaporator, Absorber)

2.2.3 High-temperature regenerator, exhaust gas heat exchanger

2.2.4 Low-temperature, high-temperature, refrigerant drain heat exchanger

2.2.5 Purge system(Including a purge pump)

2.2.6 Combustion device

2.2.7 Absorbent pump and refrigerant pump

2.2.8 Control device

### 2.3 Manufacturing Specification

2.3.1 Upper part(Low-temperature Regenerator, Condenser)

1) It is a Shell & Tube type heat exchanger and consists of a low-temperature Regenerator and a condenser.

2) High-efficiency heat-transfer tube which is specially processed is used for the heat transfer tubes in the low-temperature regenerator and the condenser.

3) The heat-transfer tube should also be assembled with mechanical extension pipe by a tube plate so that it can be replaced.

4) Install an eliminator between the low-temperature regenerator and the condenser to prevent absorbent from moving over to the condenser with the refrigerant steam generated at the low-temperature regenerator.

5) The maximum use pressure of cooling water is 10kg/cm<sup>2</sup>G.

2.3.2 Lower part(Evaporator, Absorber)

1) It is a Shell & Tube type heat exchanger and consists of a evaporator and an absorber.

2) High-efficiency heat-transfer tube which is specially processed is used for the heat transfer tubes in the evaporator and the absorber.

3) The heat-transfer tube should also be assembled with mechanical extension pipe by a tube plate so that it can be replaced.

4) Install an eliminator between the evaporator and the absorber to prevent absorbent from moving over to the evaporator.

5) Absorbent and refrigerant are sprayed evenly on the surface of the heat-transfer tube by gravity and capillary through installing a tray at the top of the evaporator and absorber and don't use the spray nozzle which needs the power of a pump.

6) Install a bypass pipe between the evaporator and the absorber so that pure refrigerant can be regenerated by bypassing the refrigerant from the evaporator to the absorber in case the refrigerant is contaminated.

7) Install a water cut-off switch at the chilled water to prevent chilled water from being frozen.

8) The maximum use pressure of chilled water and cooling water is 10kg/cm<sup>2</sup>G.

2.3.3 High-temperature regenerator and exhaust gas heat exchanger

1) It has a normal fire tube boiler type structure. Absorbent is charged at the shell and exhaust gas passes through the fire tube for the first heat exchange.

2) The exhaust gas which completed the first heat exchange conducts the second heat exchange at the fin-tube structured exhaust gas heat exchanger.

3) Rolled steel for weldment structure which has superior corrosion resistance is used for the smoke chamber material which contacts high-temperature combustion fire and exhaust gas, and carbon steel pipe for pressure piping is used for the fire tube material.

4) Insert a baffle inside the fire tube so that exhaust gas forms swirling to enhance heat exchange efficiency of the fire tube. The structure of the baffle should allow easy inspection and cleaning.

5) Install an eliminator at the top of the high-temperature regenerator to prevent absorbent from moving over to the low-temperature regenerator with the refrigerant steam generated.

6) Install a level bar for liquid detection to control the absorbent level inside the high-temperature regenerator.

2.3.4 Low-temperature, high-temperature, refrigerant drain heat exchanger

1) The low-temperature and high-temperature heat exchangers are a welded type plate heat exchanger, and the refrigerant drain heat exchanger is composed of a brazing type plate heat exchanger.

2) STS430 which has superior corrosion resistance is used for the interior material of the low-temperature and high-temperature heat exchangers.

2.3.5 Purge system

1) It consists of vacuum pump, separator, low chamber,

vacuum pressure transmitter in the range of 0-750mmHg, and control valve and prints out the pressure in digital.

2) Apply a high-efficiency purge system with the absorbent nozzle spray type and improve the screw contact parts in weldment structure to improve vacuum maintenance capacity so that purge system control number by the vacuum pump is reduced.

3) Digital auto purge system(Optional)

It completely collects and stores non-condensable gas inside the machine during machine operation, and in case the purge tank pressure reaches the setting value, the vacuum sensor detects it, and value control and vacuum pump operation is automatically made to exhaust the non-condensable gas.

2.3.6 Combustion device

1) It consists of burner, air blower, sound absorber, cut-off valve and fuel control valve.

2) It senses the outlet temperatures of chilled water and hot water and controls the fuel and air volumes in PID (Proportion, Integration, Differentiation) by the instruction of the capacity control device.

2.3.7 Absorbent pump and refrigerant pump

1) It doesn't need separate lubricant and cooling devices and uses the Non-Seal Canned Motor Pump which houses all revolving parts such as a pump and a motor in a closed case to maintain the inside of the chiller-heater vacuum.

2.3.8 Control Device

1) Structure of Control Panel

The control panel consists of microcomputer(Master/Slave Board, Display Board, Relay Board), power supply device for stable power supply, circuit breaker for other control or safety, electronic contactor, and relay for control. Major functions of each module are as follows.

2) Master/Slave Board

Main module should be applied with a high performance microprocessor and conducts the control function optimized to the mechanical devices, and the high-precision A/D(Analog/Digital) converter should measure various temperature sensors and display or apply in control. Also, RS-485 communication port is embedded to support customer's remote monitoring and control so that simple control can easily response to customers' automated buildings.

3) Display Board

Display board is composed of setting value required for various operation data and machine operation, display which shows abnormal data in text, key input which inputs various data or selects menu, and LED lamp display which shows major status of the equipment such as machine operation/stop important to machine operation, absorbent pump, refrigerant pump, purge pump, abnormality, etc. Especially, for those control devices the operator uses frequently, they should be controlled by direct key use, and

other controls can be made by selecting menu to enhance operator convenience.

The control keys are composed of six menu control keys, three manual control valve control keys, three manual purge pump control keys, and two operation/stop keys for operation/stop. In preparation of the control key failure, manual control menu can control. Also, the display can display operating status in Korean, Chinese, or English selected by the operator, which enhances operator's convenience.

4) Relay Board

Input/output module should be composed of digital input which checks various switches' operation and digital output which controls machine operation. Also, input/output module should be installed with a photo coupler to cut-off various noises, and by letting all data transmitted/received with the main module by communication, the malfunction caused by electronic wave occurring when the data are transmitted/received with normal cables should be prevented, which secures high reliability.

2.3.9 Characteristics of Control Device

1) Convenient Operating Data Management

A seven-inch color LCD is applied so that much operating information can be checked in one screen, and the customer saves 300 times of analog data(Example: temperature data) by each channel so that he/she can use for daily operation record or maintenance.

Also, the trends of temperature change can be easily understood by graphing chilled and hot water outlet temperature and high-temperature regenerator temperature in real time.

2) Self Diagnosis and Failure History Record

The microcomputer monitors the machine status during stop or operation and notifies the operator by using screen message, alarm lamp, or buzzer and at the same time automatically records the time and failure data which can be easily used during maintenance. Especially, failure type should be classified to warning and abnormality so that if a warning notice should be issued, its content is expressed in text and the operation continues, which minimized unnecessary machine stops.

3) Optimized Artificial Intelligence Control Algorithm

• Soft startup

Slowly control the heat input to prevent any machine impact caused by sudden heat supply in startup.

• Advanced Digital PID Control

The digital PID control linked with soft startup should automatically recognize the optimal PID control point in startup or when the operation mode changes from manual to auto and reflect it to control equations so that unnecessary machine stops is to be minimized, and stable and precise temperature control can be made.

• Preventative Operation against Crystallization

Measure the temperature of each part during operation to calculate density and conduct first and second preventative operation based on that result so that an abnormality is prevented in advance.

• Preventative Operation against High Temperature Occurrence at the High-temperature Regenerator

Monitor the temperature change of the high-temperature regenerator at all times and conduct a preventative operation before the temperature of the high-temperature regenerator becomes too high.

• Responsive Control to Cooling Water Temperature Higher efficient operation is possible by controlling fuel heat input depending on the cooling water inlet temperature.

• Optimal Dilution Operation Cycle Control

When stopping operation, the algorithm of the micro-computer varies the operation hours of the refrigerant pump and absorbent pump No. 1 depending on absorbent the temperature of the high-temperature regenerator so that shortened dilution operation can save the operating cost of auxiliary devices. Also, when restarting, the immediate cooling/heating operation startup is possible without a separate dilution operation.

• Scheduled Operation Function

Apply the schedule operation function which can select operation/stop by day up to 11 times or by dates and holidays and control temperature setting to enhance the convenience of machine operation(Scheduled operation).

• Operating Function against Power Breakdown

This function checks power breakdown schedule at the controller and conducts the functions such as auto restart, auto dilution operation, warning, etc. in accordance with the power breakdown time.

• Absorbent Pump Inverter Control

By the variable control(Stepless control) depending on the rotation number of the absorbent pump and controlling the absorbent volume circulating from the absorber to the high-temperature regenerator, partial load efficiency is improved, and the time to reach regulated status is shortened in the initial startup.

• Soft Start of the Absorbent Pump

Slowly increase the rotation number for 30 seconds when starting the absorbent pump to prevent any machine impact in startup, which protects the absorbent pump and enhance durability of the piping and heat exchanger.

4) Strong Customer Support Function

• Communication Function for Building Automation and Remote Monitoring Control.

This function is equipped with a standard communication function(RS485, Modbus Standard) to connect easily with the monitoring system and provides no-voltage input/output to operate/stop remotely by simple electric wiring or to monitor major operation status of the machine.

Also, as an optional specification, BACnet or Lon can be additionally installed to enhance customers' convenience.

• Help Function

This function remembers the content of the failure when it occurs, and when the operator selects it in the menu following the failure content, the function enhances operator's convenience by showing the actions for failure.

2.3.10 Automatic Safety Device

1) Chilled/hot water and cooling water safety device, high-temperature regenerator protection device, motor protection device, absorbent crystallization protection device, and combustion safety device, etc. are included.

2) Chilled/hot water and cooling water safety device

• Chilled/hot water pump Interlock contact

• Cooling water pump Interlock contact

• Chilled/hot water cut-off switch: chilled/hot water volume less than 50%

• Chilled water temperature(Low): chilled water outlet temperature lower than 2.5°C

• Hot water temperature(High): hot water outlet temperature higher than 70°C

• Cooling water temperature(Low): cooling water inlet temperature lower than 19°C for 30 minutes

• Evaporator refrigerant temperature(Low): refrigerant temperature lower than 2.5°C(Optional)

※ Since operation/stop signal of chilled water and cooling water pumps and the interlock contact are very important safety devices which can prevent chiller-heater freeze and safety accidents, be sure to wire so that the chiller-heater, the chilled water pump, and the cooling water pump are interlocked and operated.

※ Also, in case multiple cooling water pipes are connected in parallel, automatic cut-off valve should be installed to prevent water from flowing to the cooling water pipe of the relevant chiller-heater, and then the automated cut-off valve should be installed to open and close in link with LG Electronics control devices. The automatic cut-off valve should open and close in link and synchronization with the operation/stop signal of the cooling water pump provided by LG Electronics.

• Details should be consulted with LG Electronics.

3) High-temperature regenerator protection device

• High-temperature regenerator temperature(High): above 165°C in cooling, above 130°C in heating

• High-temperature regenerator pressure(High) above 0kg/cm<sup>2</sup>G

• High-temperature regenerator liquid level(Low): emergency alarm

• High-temperature regenerator liquid level(High): automatic return

• Exhaust gas temperature(High): above 300°C for gas type, above 350°C for oil type

4) Motor protection device

- Absorbent pump thermos relay
- Refrigerant pump thermos relay
- Purge pump thermos relay
- Burner air blower thermos relay

## 5) Automatic absorbent crystallization protection device

- In cooling operation, in case the absorbent density calculated by the microcomputer is equal or higher than 65%, limit the fuel heat input to 60% and operate for 10 minutes. Then, recalculate density and if it is not below 65%, abnormal high density is activated to stop the equipment.
- Low-temperature regenerator absorbent temperature sensor
- Absorbent over flow: resolve initial crystallization symptom
- Condenser refrigerant temperature sensor
- Refrigerant over flow: automatic adjustment of the maximum load density
- Display density on the LCD screen

## 6) Combustion safety device

- Various safety devices are installed complying with the safety standard for combustible equipment, and especially a self-leakage detection device is installed to enhance safety.
- Supply/ventilation fan operation/stop contact
- The burner is equipped with protect relay, fire detector, air pressure switch, high combustion limit switch, low combustion limit switch, gas pressure switch(For gas type only), fuel cut-off verification sub-switch(For gas type only), etc.

## 3. Work Scope

Item	Owner	Remark
Body Painting	LG Electronics	Body: Dawn Gray Control Panel: Warm Gray
Insulation	LG Electronics	Warm insulation: NBR 19mm, Glass wool 75, 25mm Cold insulation: NBR 19mm
Delivery and Installation	LG Electronics	Deliver to the base and install
Leakage Test, Absorbent and Refrigerant Charge	LG Electronics	Conducted works before the test-run at the installation place
Exterior Piping Work	Customer	Chilled water(Hot water), cooling water, gas contact piping works
Exterior Wiring Work	Customer	Control panel first power work(Main power, control power) and all electric wiring work mutually contacting between the control panel and customers' facilities
Air supply fan or ventilation fan	Customer	For the ventilation when installing the chiller-heater at indoor
Building and Base	Customer	
Nitrogen Gas Supplement	Customer	Means gas supplement for the chiller-heater storage(When the equipment is not operated for a long time after the test run) after the test run at the site.

Item	Owner	Remark
Test Run and Operation Training	LG Electronics	Conduct two times(One day) for eight hours(The customer supplies required electricity, fuel, chilled water, and cooling water, etc.)

## 4. Supply Scope

No	Item	Remark
1	Absorption Chiller-Heater Body	
2	Absorbent(LiBr)	Bring in separately from the equipment
3	Refrigerant(H <sub>2</sub> O)	Bring in separately from the equipment
4	Burner	Bring in separately from the equipment
5	Micom	Bring in separately from the equipment
6	Chiller-Heater Instruction Manual	1 copy

## 5. Warranty and Service

5.1 The warranty period of the product terminates either "1.5 years after the product delivery" or "one year from the test run," whichever comes first.

5.2 For any product failure within the warranty period due to the components or materials of this machine or works, LG Electronics examine it and repair it free of charge if that failure is acknowledged.

5.3 Free repair is not provided for the following cases.

- 1) The failure occurred after the product is repaired in the other shop other than designated store.
- 2) It is evident that the failure occurred due to the customer's mistake in use and handling.
- 3) The product has been resold or transferred to others during warranty period.
- 4) The failure was caused by fire or natural disaster.

## 6. Others

6.1 Before manufacturing the chiller-heater, submit all facts regarding manufacturing to the customer, and manufacture after receiving customer's approval. For any item not specified in this specification, discuss with the customer and receive an approval before implementing it.

6.2 You should notify LG Electronics if you resell or transfer the product before scrapping it.

## Steam fired Absorption Chiller (WCSH Series)

### Contents

1. Application Scope
2. Equipment Specification
3. Work Scope
4. Supply Scope
5. Warranty and Service
6. Others

## 1. Application Scope

This manufacturing specification is applied to all models of double-effect steam fired absorption chiller SH-Series.

## 2. Equipment Specification

### 2.1 General

2.1.1 The absorption chiller SH-Series uses the saturated steam. The microcomputer controls cooling capacity in PID (Proportion, Integration, Differentiation).

2.1.2 Lithium Bromide(LiBr mass concentration 55%) added with anticorrosive agent(Mo type)is used for absorbent, and distilled water(H<sub>2</sub>O)is used for refrigerant.

2.1.3 The steel sheet and pipes are surface treated to prevent corrosion.

2.1.4 To check any leakage of the stored product before transportation and test-run and to prevent air infiltration, nitrogen gas of 0.3 Kg/cm<sup>2</sup>G is filled.

### 2.2 Components

2.2.1 Upper part(Low-temperature Regenerator, Condenser)

2.2.2 Lower part(Evaporator, Absorber)

2.2.3 High-temperature regenerator

2.2.4 Heat recovery unit

2.2.5 Low-temperature, high-temperature, refrigerant drain heat exchanger

2.2.6 Purge system(Including a purge pump)

2.2.7 Absorbent pump and refrigerant pump

2.2.8 Control device

### 2.3 Manufacturing Specification

2.3.1 Upper part(Low-temperature Regenerator, Condenser)

1) It is a Shell & Tube type heat exchanger and consists of a low-temperature Regenerator and a condenser.

2) High-efficiency heat-transfer tube which is specially processed is used for the heat transfer tubes in the low-temperature regenerator and the condenser.

3) The heat-transfer tube should also be assembled with mechanical extension pipe by a tube plate so that it can be replaced.

4) Install an eliminator between the low-temperature regenerator and the condenser to prevent absorbent from moving over to the condenser with the refrigerant steam generated at the low-temperature regenerator.

5) The maximum use pressure of cooling water is 10kg/cm<sup>2</sup>G.

2.3.2 Lower part(Evaporator, Absorber)

1) It is a Shell & Tube type heat exchanger and consists of a evaporator and an absorber.

2) High-efficiency heat-transfer tube which is specially processed is used for the heat transfer tubes in the evaporator and the absorber.

3) The heat-transfer tube should also be assembled with mechanical extension pipe by a tube plate so that it can be

replaced.

4) Install an eliminator between the evaporator and the absorber to prevent absorbent from moving over to the evaporator.

5) Absorbent and refrigerant are sprayed evenly on the surface of the heat-transfer tube by gravity and capillary through installing a tray at the top of the evaporator and absorber and don't use the spray nozzle which needs the power of a pump.

6) Install a bypass pipe between the evaporator and the absorber so that pure refrigerant can be regenerated by bypassing the refrigerant from the evaporator to the absorber in case the refrigerant is contaminated.

7) Install a water cut-off switch at the chilled water to prevent chilled water from being frozen.

8) The maximum use pressure of chilled water and cooling water is 10kg/cm<sup>2</sup>G.

2.3.3 High-temperature regenerator

1) Use Shell & Tube type heat exchanger and apply LG's high efficiency tube.

2) The heat-transfer tube should also be assembled with mechanical extension pipe by a tube plate so that it can be replaced.

3) Install an eliminator at the top of the high-temperature regenerator to prevent absorbent from moving over to the low-temperature regenerator with the refrigerant steam generated.

4) Install an eliminator at the top of the high-temperature regenerator to prevent absorbent from moving over to the low-temperature regenerator with the refrigerant steam generated.

5) The maximum use pressure of steam is 8kg/cm<sup>2</sup>G.

2.3.4 Heat recovery unit

1) Use brazing type plate heat exchanger.

2.3.5 Low-temperature, high-temperature, refrigerant drain heat exchanger.

1) The low-temperature and high-temperature heat exchangers are a welded type plate heat exchanger, and the refrigerant drain heat exchanger is composed of a brazing type plate heat exchanger.

2) STS430 which has superior corrosion resistance is used for the interior material of the low-temperature and high-temperature heat exchangers.

2.3.6 Purge system

1) It consists of vacuum pump, separator, low chamber, vacuum pressure transmitter in the range of 0-750mmHg, and control valve and prints out the pressure in digital.

2) Apply a high-efficiency purge system with the absorbent nozzle spray type and improve the screw contact parts in weldment structure to improve vacuum maintenance capacity so that purge system control number by the vacuum pump is reduced.

3) Digital auto purge system(Optional)

It completely collects and stores non-condensable gas inside the machine during machine operation, and in case the purge tank pressure reaches the setting value, the vacuum sensor detects it, and value control and vacuum pump operation is automatically made to exhaust the non-condensable gas.

2.3.7 Absorbent pump and refrigerant pump

1) It doesn't need separate lubricant and cooling devices and uses the Non-Seal Canned Motor Pump which houses all revolving parts such as a pump and a motor in a closed case to maintain the inside of the chiller vacuum.

2.3.8 Control Device

1) Structure of Control Panel

The control panel consists of microcomputer(Master/Slave Board, Display Board, Relay Board), power supply device for stable power supply, circuit breaker for other control or safety, electronic contactor, and relay for control. Major functions of each module are as follows.

2) Master/Slave Board

Main module should be applied with a high performance microprocessor and conducts the control function optimized to the mechanical devices, and the high-precision A/D(Analog/Digital) converter should measure various temperature sensors and display or apply in control. Also, RS-485 communication port is embedded to support customer's remote monitoring and control so that simple control can easily response to customers' automated buildings.

3) Display Board

Display board is composed of setting value required for various operation data and machine operation, display which shows abnormal data in text, key input which inputs various data or selects menu, and LED lamp display which shows major status of the equipment such as machine operation/stop important to machine operation, absorbent pump, refrigerant pump, purge pump, abnormality, etc. Especially, for those control devices the operator uses frequently, they should be controlled by direct key use, and other controls can be made by selecting menu to enhance operator convenience.

The control keys are composed of six menu control keys, three manual control valve control keys, three manual purge pump control keys, and two operation/stop keys for operation/stop. In preparation of the control key failure, manual control menu can control. Also, the display can display operating status in Korean, Chinese, or English selected by the operator, which enhances operator's convenience.

4) Relay Board

Input/output module should be composed of digital input which checks various switches' operation and digital output which controls machine operation. Also, input/output module should be installed with a photo coupler to cut-off various noises, and by letting all data transmitted/

received with the main module by communication, the malfunction caused by electronic wave occurring when the data are transmitted/received with normal cables should be prevented, which secures high reliability.

2.3.9 Characteristics of Control Device

1) Convenient Operating Data Management

A seven-inch color LCD is applied so that much operating information can be checked in one screen, and the customer saves 300 times of analog data(Example: temperature data) by each channel so that he/she can use for daily operation record or maintenance.

Also, the trends of temperature change can be easily understood by graphing chilled and hot water outlet temperature and high-temperature regenerator temperature in real time.

2) Self Diagnosis and Failure History Record

The microcomputer monitors the machine status during stop or operation and notifies the operator by using screen message, alarm lamp, or buzzer and at the same time automatically records the time and failure data which can be easily used during maintenance. Especially, failure type should be classified to warning and abnormality so that if a warning notice should be issued, its content is expressed in text and the operation continues, which minimized unnecessary machine stops.

3) Optimized Artificial Intelligence Control Algorithm

• Soft startup

Slowly control the heat input to prevent any machine impact caused by sudden heat supply in startup.

• Advanced Digital PID Control

The digital PID control linked with soft startup should automatically recognize the optimal PID control point in startup or when the operation mode changes from manual to auto and reflect it to control equations so that unnecessary machine stops is to be minimized, and stable and precise temperature control can be made.

• Preventative Operation against Crystallization

Measure the temperature of each part during operation to calculate density and conduct first and second preventative operation based on that result so that an abnormality is prevented in advance.

• Preventative Operation against High Temperature Occurrence at the High-temperature Regenerator

Monitor the temperature change of the high-temperature regenerator at all times and conduct a preventative operation before the temperature of the high-temperature regenerator becomes too high.

• Responsive Control to Cooling Water Temperature

Higher efficient operation is possible by controlling fuel heat input depending on the cooling water inlet temperature.

• Optimal Dilution Operation Cycle Control

When stopping operation, the algorithm of the micro-computer varies the operation hours of the refrigerant

pump and absorbent pump No. 1 depending on absorbent the temperature of the high-temperature regenerator so that shortened dilution operation can save the operating cost of auxiliary devices. Also, when restarting, the immediate cooling/heating operation startup is possible without a separate dilution operation.

- Scheduled Operation Function  
Apply the schedule operation function which can select operation/stop by day up to 11 times or by dates and holidays and control temperature setting to enhance the convenience of machine operation(Scheduled operation).
  - Operating Function against Power Breakdown  
This function checks power breakdown schedule at the controller and conducts the functions such as auto restart, auto dilution operation, warning, etc. in accordance with the power breakdown time.
  - Absorbent Pump Inverter Control  
By the variable control(Stepless control) depending on the rotation number of the absorbent pump and controlling the absorbent volume circulating from the absorber to the high-temperature regenerator, partial load efficiency is improved, and the time to reach regulated status is shortened in the initial startup.
  - Soft Start of the Absorbent Pump  
Slowly increase the rotation number for 30 seconds when starting the absorbent pump to prevent any machine impact in startup, which protects the absorbent pump and enhance durability of the piping and heat exchanger.
- 4) Strong Customer Support Function
- Communication Function for Building Automation and Remote Monitoring Control  
This function is equipped with a standard communication function(RS485, Modbus Standard) to connect easily with the monitoring system and provides no-voltage input/output to operate/stop remotely by simple electric wiring or to monitor major operation status of the machine.  
Also, as an optional specification, BACnet or Lon can be additionally installed to enhance customers' convenience.
  - Help Function  
This function remembers the content of the failure when it occurs, and when the operator selects it in the menu following the failure content, the function enhances operator's convenience by showing the actions for failure.
- 2.3.10 Automatic Safety Device
- 1) Chilled/hot water and cooling water safety device, high-temperature regenerator protection device, motor protection device, absorbent crystallization protection device, and combustion safety device, etc. are included.
  - 2) Chilled/hot water and cooling water safety device
    - Chilled/hot water pump Interlock contact
    - Cooling water pump Interlock contact
    - Chilled/hot water cut-off switch: chilled/hot water volume less than 50%

- Chilled water temperature(Low): chilled water outlet temperature lower than 2.5°C
  - Hot water temperature(High): hot water outlet temperature higher than 70°C
  - Cooling water temperature(Low): cooling water inlet temperature lower than 19°C for 30 minutes
  - Evaporator refrigerant temperature(Low): refrigerant temperature lower than 2.5°C(Optional)
- ※ Since operation/stop signal of chilled water and cooling water pumps and the interlock contact are very important safety devices which can prevent chiller freeze and safety accidents, be sure to wire so that the chiller, the chilled water pump, and the cooling water pump are interlocked and operated
- ※ Also, in case multiple cooling water pipes are connected in parallel, automatic cut-off valve should be installed to prevent water from flowing to the cooling water pipe of the relevant chiller, and then the automated cut-off valve should be installed to open and close in link with LG Electronics control devices. The automatic cut-off valve should open and close in link and synchronization with the operation/stop signal of the cooling water pump provided by LG Electronics.
- Details should be consulted with LG Electronics.
- 3) High-temperature regenerator protection device
- High-temperature regenerator temperature(High): above 165°C in cooling, above 130°C in heating
  - High-temperature regenerator pressure(High) above 0kg/cm<sup>2</sup>G
  - High-temperature regenerator liquid level(Low): emergency alarm
  - High-temperature regenerator liquid level(High): automatic return
- 4) Motor protection device
- Absorbent pump thermos relay
  - Refrigerant pump thermos relay
  - Purge pump thermos relay
  - Burner air blower thermos relay
- 5) Automatic absorbent crystallization protection device
- In cooling operation, in case the absorbent density calculated by the microcomputer is equal or higher than 65%, limit the fuel heat input to 60% and operate for 10 minutes. Then, recalculate density and if it is not below 65%, abnormal high density is activated to stop the equipment.
  - Low-temperature regenerator absorbent temperature sensor
  - Absorbent over flow: resolve initial crystallization symptom
  - Condenser refrigerant temperature sensor
  - Refrigerant over flow: automatic adjustment of the maximum load density
  - Display density on the LCD screen

## 3. Work Scope

Item	Owner	Remark
Body Painting	LG Electronics	Body: Dawn Gray Control Panel: Warm Gray
Insulation	LG Electronics	Warm insulation: NBR 19mm, Glass wool 75, 25mm Cold insulation: NBR 19mm
Delivery and Installation	LG Electronics	Deliver to the base and install
Leakage Test, Absorbent and Refrigerant Charge	LG Electronics	Conducted works before the test-run at the installation place
Exterior Piping Work	Customer	Chilled water(Hot water), cooling water, gas contact piping works
Exterior Wiring Work	Customer	Control panel first power work(Main power, control power) and all electric wiring work mutually contacting between the control panel and customers' facilities
Air supply fan or ventilation fan	Customer	For the ventilation when installing the chiller at indoor
Building and Base	Customer	
Nitrogen Gas Supplement	Customer	Means gas supplement for the chiller storage(When the equipment is not operated for a long time after the test run) after the test run at the site.
Test Run and Operation Training	LG Electronics	Conduct two times(One day) for eight hours(The customer supplies required electricity, fuel, chilled water, and cooling water, etc.)

## 4. Supply Scope

No	Item	Remark
1	Absorption Chiller-Heater Body	
2	Absorbent(LiBr)	Bring in separately from the equipment
3	Refrigerant(H <sub>2</sub> O)	Bring in separately from the equipment
4	Burner	Bring in separately from the equipment
5	Micom	Bring in separately from the equipment
6	Chiller-Heater Instruction Manual	1 copy

## 5. Warranty and Service

- 5.1 The warranty period of the product terminates either "1.5 years after the product delivery" or "one year from the test run," whichever comes first.
- 5.2 For any product failure within the warranty period due to the components or materials of this machine or works, LG Electronics examine it and repair it free of charge if that failure is acknowledged.
- 5.3 Free repair is not provided for the following cases.
- 1) The failure occurred after the product is repaired in the other shop other than designated store.
  - 2) It is evident that the failure occurred due to the customer's mistake in use and handling.
  - 3) The product has been resold or transferred to others during

warranty period.  
4) The failure was caused by fire or natural disaster.

## 6. Others

- 6.1 Before manufacturing the chiller, submit all facts regarding manufacturing to the customer, and manufacture after receiving customer's approval.  
For any item not specified in this specification, discuss with the customer and receive an approval before implementing it.
- 6.2 You should notify LG Electronics if you resell or transfer the product before scrapping it.

# Guide specification

## Hot-water driven Absorption Chiller (WCMH Series)

### Contents

1. Application Scope
2. Equipment Specification
3. Work Scope
4. Supply Scope
5. Warranty and Service
6. Others

# Guide specification

## 1. Application Scope

This manufacturing specification is applied to all models of the absorption chiller MH-Series.

## 2. Equipment Specification

### 2.1 General

2.1.1 The absorption chiller MH-Series uses the hot water. The microcomputer controls cooling capacity in PID(Proportion, Integration, Differentiation).

2.1.2 Lithium Bromide(LiBr mass concentration 55%) added with anticorrosive agent(Mo type)is used for absorbent, and distilled water(H<sub>2</sub>O)is used for refrigerant.

2.1.3 The steel sheet and pipes are surface treated to prevent corrosion.

2.1.4 To check any leakage of the stored product before transportation and test-run and to prevent air infiltration, nitrogen gas of 0.3 Kg/cm<sup>2</sup>G is filled.

### 2.2 Components

2.2.1 Upper part(Generator, Condenser)

2.2.2 Lower part(Evaporator, Absorber)

2.2.3 Heat exchanger

2.2.4 Purge system(Including a purge pump)

2.2.5 Absorbent pump and refrigerant pump

2.2.6 Control device

### 2.3 Manufacturing Specification

2.3.1 Upper part(Generator, Condenser)

1) It is a Shell & Tube type heat exchanger and consists of a low-temperature Regenerator and a condenser.

2) High-efficiency heat-transfer tube which is specially processed is used for the heat transfer tubes in the low-temperature regenerator and the condenser.

3) The heat-transfer tube should also be assembled with mechanical extension pipe by a tube plate so that it can be replaced.

4) Install an eliminator between the low-temperature regenerator and the condenser to prevent absorbent from moving over to the condenser with the refrigerant steam generated at the low-temperature regenerator.

5) The maximum use pressure of cooling water is 16kg/cm<sup>2</sup>G.

2.3.2 Lower part(Evaporator, Absorber)

1) It is a Shell & Tube type heat exchanger and consists of a evaporator and an absorber.

2) High-efficiency heat-transfer tube which is specially processed is used for the heat transfer tubes in the evaporator and the absorber.

3) The heat-transfer tube should also be assembled with mechanical extension pipe by a tube plate so that it can be replaced.

4) Install an eliminator between the evaporator and the absorber to prevent absorbent from moving over to the

evaporator.

5) Absorbent and refrigerant are sprayed evenly on the surface of the heat-transfer tube by gravity and capillary through installing a tray at the top of the evaporator and absorber and don't use the spray nozzle which needs the power of a pump.

6) Install a bypass pipe between the evaporator and the absorber so that pure refrigerant can be regenerated by bypassing the refrigerant from the evaporator to the absorber in case the refrigerant is contaminated.

7) Install a water cut-off switch at the chilled water to prevent chilled water from being frozen.

8) The maximum use pressure of chilled water and cooling water is 10kg/cm<sup>2</sup>G.

2.3.3 Heat exchanger

1) Use high efficiency compact type plate heat exchanger. STS430 which has superior corrosion resistance is used for the interior material of the heat exchangers.

2.3.4 Purge system

1) It consists of vacuum pump, separator, low chamber, vacuum pressure transmitter in the range of 0-700mmHg, and control valve and prints out the pressure in digital.

2) Apply a high-efficiency purge system with the absorbent nozzle spray type and improve the screw contact parts in weldment structure to improve vacuum maintenance capacity so that purge system control number by the vacuum pump is reduced.

3) Digital auto purge system(Optional)

It completely collects and stores non-condensable gas inside the machine during machine operation, and in case the purge tank pressure reaches the setting value, the vacuum sensor detects it, and value control and vacuum pump operation is automatically made to exhaust the non-condensable gas.

2.3.5 Absorbent pump and refrigerant pump

1) It doesn't need separate lubricant and cooling devices and uses the Non-Seal Canned Motor Pump which houses all revolving parts such as a pump and a motor in a closed case to maintain the inside of the chiller vacuum.

2.3.6 Control Device

1) Structure of Control Panel

The control panel consists of microcomputer(Master/Slave Board, Display Board, Relay Board), power supply device for stable power supply, circuit breaker for other control or safety, electronic contactor, and relay for control. Major functions of each module are as follows.

2) Master/Slave Board

Main module should be applied with a high performance microprocessor and conducts the control function optimized to the mechanical devices, and the high-precision A/D(Analog/Digital) converter should measure various temperature sensors and display or apply in control. Also, RS-485 communication port is embedded to support

customer's remote monitoring and control so that simple control can easily response to customers' automated buildings.

### 3) Display Board

Display board is composed of setting value required for various operation data and machine operation, display which shows abnormal data in text, key input which inputs various data or selects menu, and LED lamp display which shows major status of the equipment such as machine operation/stop important to machine operation, absorbent pump, refrigerant pump, purge pump, abnormality, etc. Especially, for those control devices the operator uses frequently, they should be controlled by direct key use, and other controls can be made by selecting menu to enhance operator convenience.

The control keys are composed of six menu control keys, three manual control valve control keys, three manual purge pump control keys, and two operation/stop keys for operation/stop. In preparation of the control key failure, manual control menu can control. Also, the display can display operating status in Korean, Chinese, or English selected by the operator, which enhances operator's convenience.

### 4) Relay Board

Input/output module should be composed of digital input which checks various switches' operation and digital output which controls machine operation. Also, input/output module should be installed with a photo coupler to cut-off various noises, and by letting all data transmitted/received with the main module by communication, the malfunction caused by electronic wave occurring when the data are transmitted/received with normal cables should be prevented, which secures high reliability.

#### 2.3.7 Characteristics of Control Device

##### 1) Convenient Operating Data Management

A seven-inch color LCD is applied so that much operating information can be checked in one screen, and the customer saves 300 times of analog data(Example: temperature data) by each channel so that he/she can use for daily operation record or maintenance.

Also, the trends of temperature change can be easily understood by graphing chilled and hot water outlet temperature and high-temperature regenerator temperature in real time.

##### 2) Self Diagnosis and Failure History Record

The microcomputer monitors the machine status during stop or operation and notifies the operator by using screen message, alarm lamp, or buzzer and at the same time automatically records the time and failure data which can be easily used during maintenance. Especially, failure type should be classified to warning and abnormality so that if a warning notice should be issued, its content is expressed in text and the operation continues, which minimized

unnecessary machine stops.

### 3) Optimized Artificial Intelligence Control Algorithm

#### • Soft startup

Slowly control the heat input to prevent any machine impact caused by sudden heat supply in startup.

#### • Advanced Digital PID Control

The digital PID control linked with soft startup should automatically recognize the optimal PID control point in startup or when the operation mode changes from manual to auto and reflect it to control equations so that unnecessary machine stops is to be minimized, and stable and precise temperature control can be made.

#### • Preventative Operation against Crystallization

Measure the temperature of each part during operation to calculate density and conduct first and second preventative operation based on that result so that an abnormality is prevented in advance.

#### • Preventative Operation against High Temperature Occurrence at the High-temperature Regenerator

Monitor the temperature change of the high-temperature regenerator at all times and conduct a preventative operation before the temperature of the high-temperature regenerator becomes too high.

#### • Responsive Control to Cooling Water Temperature

Higher efficient operation is possible by controlling fuel heat input depending on the cooling water inlet temperature.

#### • Optimal Dilution Operation Cycle Control

When stopping operation, the algorithm of the micro-computer varies the operation hours of the refrigerant pump and absorbent pump No. 1 depending on absorbent the temperature of the high-temperature regenerator so that shortened dilution operation can save the operating cost of auxiliary devices. Also, when restarting, the immediate cooling/heating operation startup is possible without a separate dilution operation.

#### • Scheduled Operation Function

Apply the schedule operation function which can select operation/stop by day up to 11 times or by dates and holidays and control temperature setting to enhance the convenience of machine operation(Scheduled operation).

#### • Operating Function against Power Breakdown

This function checks power breakdown schedule at the controller and conducts the functions such as auto restart, auto dilution operation, warning, etc. in accordance with the power breakdown time.

#### • Absorbent Pump Inverter Control

By the variable control(Stepless control) depending on the rotation number of the absorbent pump and controlling the absorbent volume circulating from the absorber to the high-temperature regenerator, partial load efficiency is improved, and the time to reach regulated status is shortened in the initial startup.

#### • Soft Start of the Absorbent Pump

Slowly increase the rotation number for 30 seconds when starting the absorbent pump to prevent any machine impact in startup, which protects the absorbent pump and enhance durability of the piping and heat exchanger.

### 4) Strong Customer Support Function

#### • Communication Function for Building Automation and Remote Monitoring Control

This function is equipped with a standard communication function(RS485, Modbus Standard) to connect easily with the monitoring system and provides no-voltage input/output to operate/stop remotely by simple electric wiring or to monitor major operation status of the machine.

Also, as an optional specification, BACnet or Lon can be additionally installed to enhance customers' convenience.

#### • Help Function

This function remembers the content of the failure when it occurs, and when the operator selects it in the menu following the failure content, the function enhances operator's convenience by showing the actions for failure.

#### 2.3.8 Automatic Safety Device

1) Chilled/hot water and cooling water safety device, high-temperature regenerator protection device, motor protection device, absorbent crystallization protection device, and combustion safety device, etc. are included.

2) Chilled/hot water and cooling water safety device

#### • Chilled/hot water pump Interlock contact

#### • Cooling water pump Interlock contact

#### • Chilled/hot water cut-off switch: Chilled/hot water volume less than 50%

#### • Chilled water temperature(Low): Chilled water outlet temperature lower than 2.5°C

#### • Cooling water temperature(Low): Cooling water inlet temperature lower than 19°C for 30 minutes

※ Since operation/stop signal of chilled water and cooling water pumps and the interlock contact are very important safety devices which can prevent chiller freeze and safety accidents, be sure to wire so that the chiller, the chilled water pump, and the cooling water pump are interlocked and operated.

※ Also, in case multiple cooling water pipes are connected in parallel, automatic cut-off valve should be installed to prevent water from flowing to the cooling water pipe of the relevant chiller, and then the automated cut-off valve should be installed to open and close in link with LG Electronics control devices. The automatic cut-off valve should open and close in link and synchronization with the operation/stop signal of the cooling water pump provided by LG Electronics.

#### • Details should be consulted with LG Electronics.

3) Generator protection device

#### • Generator temperature(High): above 105°C

4) Motor protection device

#### • Absorbent pump thermos relay

#### • Refrigerant pump thermos relay

#### • Purge pump thermos relay

5) Automatic absorbent crystallization protection device

#### • Absorbent over flow: resolve initial crystallization symptom

#### • Refrigerant over flow: automatic adjustment of the maximum load density

## 3. Work Scope

Item	Owner	Remark
Body Painting	LG Electronics	Body: Dawn Gray Control Panel: Warm Gray
Insulation	LG Electronics	Warm insulation: NBR 19mm, Glass wool 75, 25mm Cold insulation: NBR 19mm
Delivery and Installation	LG Electronics	Deliver to the base and install
Leakage Test, Absorbent and Refrigerant Charge	LG Electronics	Conducted works before the test-run at the installation place
Exterior Piping Work	Customer	Chilled water(Hot water), cooling water, gas contact piping works
Exterior Wiring Work	Customer	Control panel first power work(Main power, control power) and all electric wiring work mutually contacting between the control panel and customers' facilities
Air supply fan or ventilation fan	Customer	For the ventilation when installing the chiller at indoor
Building and Base	Customer	
Nitrogen Gas Supplement	Customer	Means gas supplement for the chiller storage(When the equipment is not operated for a long time after the test run) after the test run at the site.
Test Run and Operation Training	LG Electronics	Conduct two times(One day) for eight hours(The customer supplies required electricity, fuel, chilled water, and cooling water, etc.)

## 4. Supply Scope

No	Item	Remark
1	Absorption Chiller-Heater Body	
2	Absorbent(LiBr)	Bring in separately from the equipment
3	Refrigerant(H <sub>2</sub> O)	Bring in separately from the equipment
4	Burner	Bring in separately from the equipment
5	Micom	Bring in separately from the equipment
6	Chiller-Heater Instruction Manual	1 copy

## 5. Warranty and Service

5.1 The warranty period of the product terminates either "1.5 years after the product delivery" or "one year from the test run," whichever comes first.

5.2 For any product failure within the warranty period due to the components or materials of this machine or works, LG Electronics examine it and repair it free of charge if that failure is acknowledged.





