

**LG Electronics, Home appliance & Air solution company**

56, Digital-ro 10-gil, Geumcheon-gu, Seoul, Republic of Korea (153-801)

[www.lg.com](http://www.lg.com)

[www.lgeaircon.com](http://www.lgeaircon.com)

**LG HVAC SOLUTION**

# AIR COOLED INVERTER SCROLL CHILLER

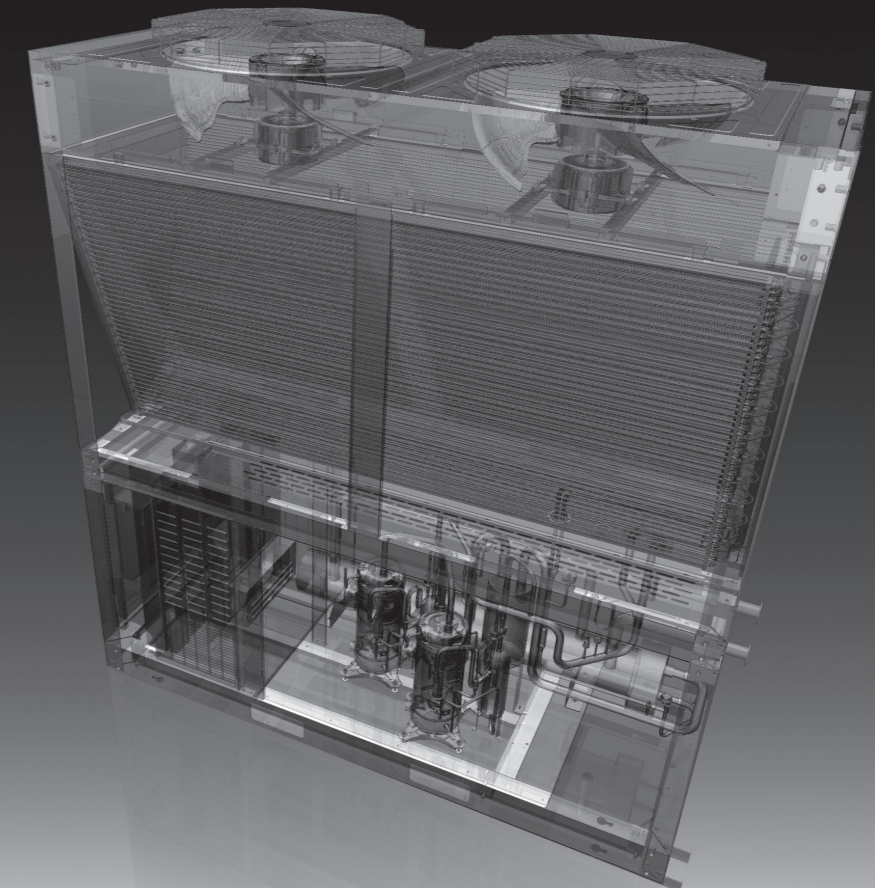

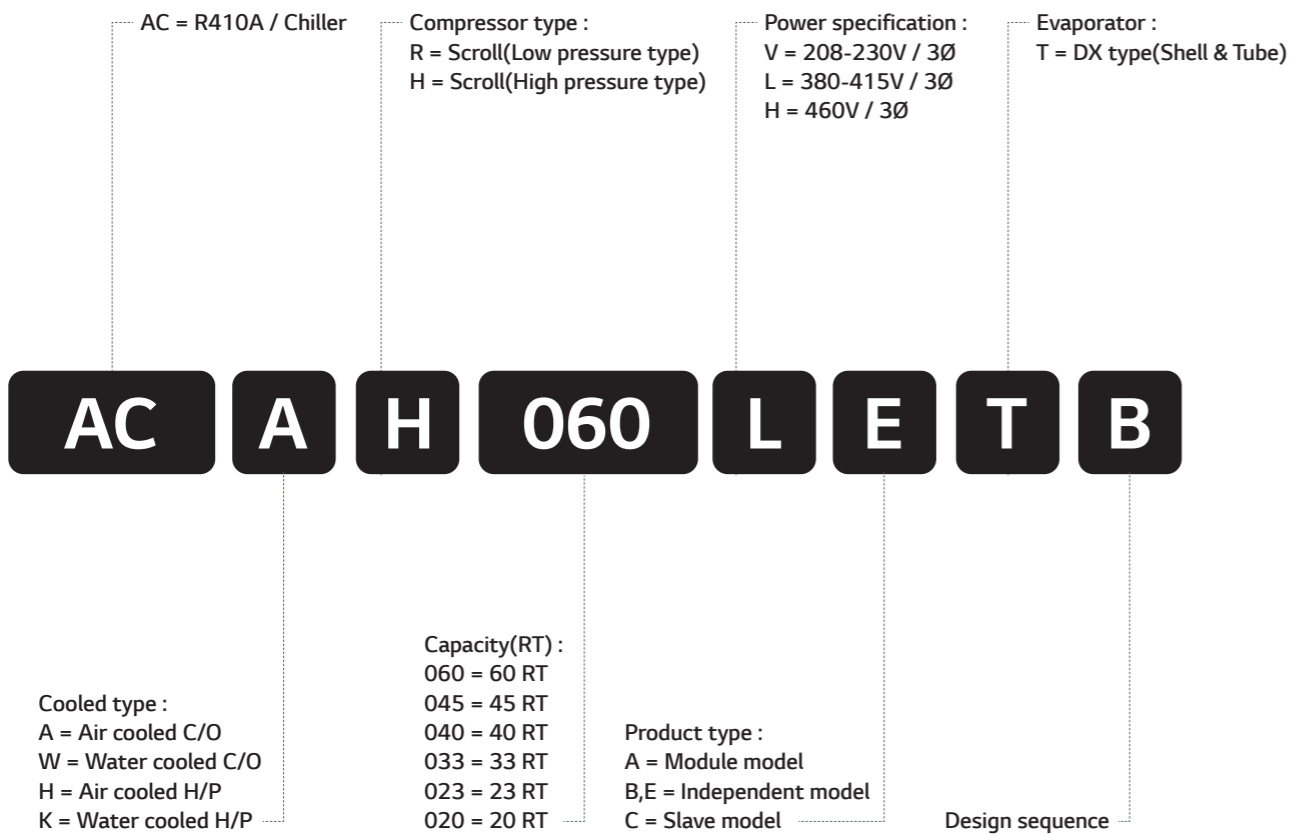

## Contents

- 02 Nomenclature
- 03 Line up & Introduction
- 04 Features
- 06 Specification
- 12 Electric characteristics
- 13 Outline dimension
- 18 Foundation
- 20 Piping diagram
- 25 Wiring diagram
- 35 Installation of chiller
- 41 Guide specification

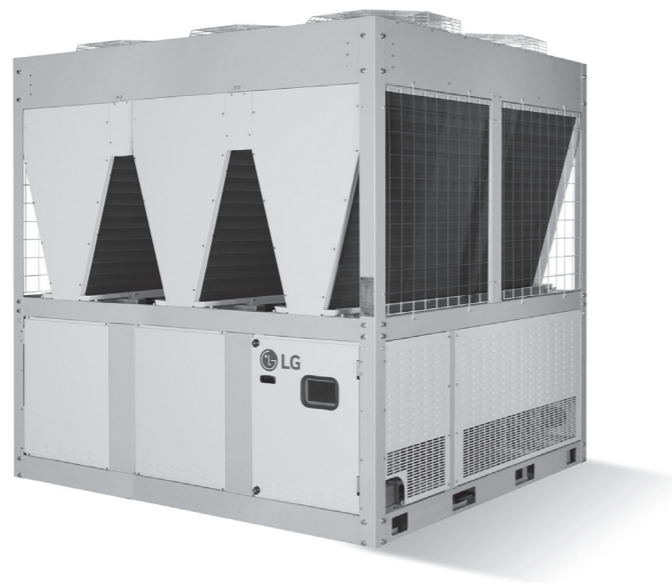

## Line up

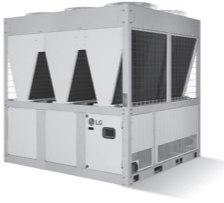
Model		10	20	30	40	50	60	70
 Cooling Only	220V		18RT			55RT		
	380V		18RT				63RT	
	460V		18RT				63RT	
Heat Pump	380-415V		18RT	Cooling Capacity	42RT			
			20RT	Heating Capacity	46RT			

\* @T1 Condition

\* Up to 5 units per 1 HMI can be controlled.

LG Air cooled water chillers are complete, self-contained automatic refrigerating units that include the latest in engineering components arranged to provide a compact and efficient unit. Each unit is completely assembled; factory wired, evacuated, charged, tested and comes complete and ready for installation. Each unit consists of multiple air-cooled condensers with integral sub-cooler sections, two or more accessible hermetically scroll compressors, high efficiency evaporator, and electronic expansion valves.

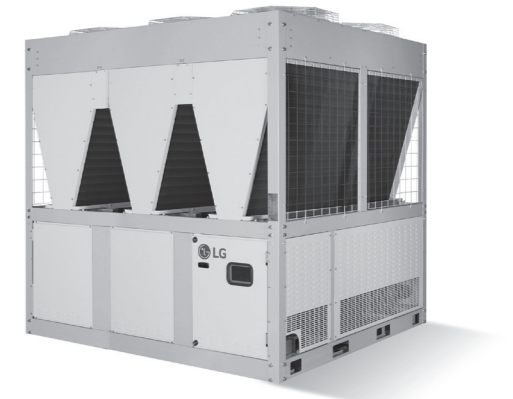

- High-performance compressor manufactured by LG to ensure that the chiller is economical and durable with low vibration and low noise.
- Highly integrated motherboard is adopted and hence the function is strong and reliable.
- Advanced control algorithm is adopted to control chiller in advance and hence avoid frequent stoppage protection of chiller.
- We have set complete safety protection function in order to make chiller safely and reliably run.
- The linkage control and remote monitoring function of peripheral equipment ensure that the chiller can run safely and the operation and monitoring are convenient.
- The selection of excellent raw materials and fittings is the key to guaranteeing chiller quality.

### Excellent reliability and Powerful operation

The cutting-edge design of Air-cooled scroll chiller accomplishes high performance and reliability for industrial and commercial

market.

LG Air-cooled scroll compressors are precisely machined from solid compound metal bar using profound cutting process. Tolerance is maintained within a few microns just like one-tenth hair thickness. Robust components with highly skilled assembling process help the compressor last for a long time. LG condenser production technology is already well-known to worldwide air conditioning manufacturing industries because of its leading technologies.

### World class high efficiency

The evaporator uses internally grooved tubes having helical angle which enhanced the refrigerant side heat transfer performance. The V-shape of condenser allows the largest heat transfer surface area for the same footprint, resulting in largest heat transfer performance when the configuration is optimally designed.

The LG V-shape condenser coil was designed using numerical and experimental analysis, having optimum air flow path to



optimize heat rejection performance.

Also, the enhanced condenser fin geometry allows the optimum heat transfer performance at small air side pressure drop, and this reduces the fan-motor power consumption. The fin is pre-coated to prevent corrosion at normal conditions and epoxy coated fin condenser which is sustainable in harsh conditions, is also available as option.

### Low noise and Low vibration

The unit was designed with a compact structure and robust assembly. The condenser fan is completed with high-efficiency wing style axial fan and direct driven motor for low sound level. The unit configures compressor sound insulation box(Optional), which makes LG chillers silent and stable.

### Installation, start-up

- Small operating footprint fit most retrofit applications.
- Factory testing for high reliability.
- Factory-installed and tested controls help to reduce start up time and minimized extra cost.
- Display temperatures and pressure for each component spot.

### Compressor specification

- Hermetically sealed DC Scroll compressor.
- Variable Speed Drive(VSD)
- The VSD optimized for part-load conditions.
- A refrigerant dispersing device is set internally to the compressor for motor cooling.

### Factory testing/Unit performance testing

LG air-cooled scroll chillers are given a complete functional test at the factory. LG computer-based testing programs completely check the components including sensors, wiring, electronics and microprocessor control functions.

LG promotes factory performance tests for air-cooled chillers to show that we stand behind the products which are designed and build up.

The benefits of a performance test include verification of performance, prevention of operational problems, and assurance of a smooth start-up. Each compressor is run and tested to verify capacity and efficiency.

### Structural strength analysis

Structure is designed to ensure stiffness for various disturbances by steps of structure modeling, meshing, excitation and evaluation.

#### Structural strength evaluation simulation

### Aerodynamic analysis

Condenser part is appropriately designed by aerodynamic analysis like inlet and outlet uniform airflow design and dead zone reduction design.

#### Heat circulation evaluation simulation

### Refrigerant R410A

System designed with Eco-friendly refrigerant R410A which does not harm the ozone layer & protects the environment. The HCFC(R22, R123) series cannot produce any more from 2020 according to the Montreal Protocol for protection of ozone layer.

### Black fin(Heat exchanger)

Heat Exchanger of outdoor unit is the core part that contributes to consistent cooling performance, yet is most vulnerable to corrosion. LG's exclusive black fin is highly corrosion resistant, designed to perform in corrosive environments such as coastal area.

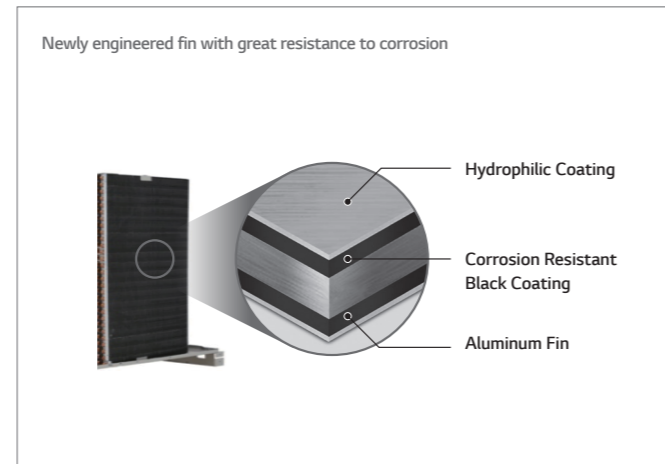

Black fin(Heat exchanger)

#### Black coating

The black coating is heavy anti-corrosion treatment applied to industrial equipment in the ocean. This special coating protects heat exchanger from high salinity, humidity and pollution

#### Salt water spray test

Heat exchanger with black fin passed 3,000 hour salt water spray test, while conventional heat exchanger started to corrode after 1,000 hours.

### Selection guide

The product information required in various requirements is written in detail from performance data.

If you need a product for special system application or product with the condition outside this catalogue, please get

consultation from nearby sales office or specialty store.

### Selection procedure

#### 1. Check usage condition

Before selecting the model, the following usage conditions must be decided.

- Chilled water in/out temperature and outdoor temperature
- Chilled water flow amount(Flow amount can be calculated if you know the freezing load and chilled water in/out temperature.)

#### 2. Selecting candidate model

Required rated capability is selected through load calculation, and you can select the corresponding model by looking at specification & performance data table.

When you select the candidate model, do not select a model with less volume than the required rated capability, but select a model with the same or bigger volume.

#### 3. Performance adjustment for fouling

The data in this technical data manual is based on chilled water fouling coefficient of 0.000018 m<sup>2</sup>°C/W at sea level. If altitude or fouling coefficient is different, you have to apply appropriate adjustment coefficient from the following table to calculate data for the operation condition.

Altitude	Water in/out temperature difference(°C)	Fouling coefficient			
		0.000018 m <sup>2</sup> °C/W		0.000054 m <sup>2</sup> °C/W	
		Cooling capability	Power consumption	Cooling capability	Power consumption
Sea level (0m)	4	0.991	0.998	0.979	0.996
	5	1.000	1.000	0.990	0.998
	6	1.010	1.002	1.001	1.000
	7	1.020	1.005	1.010	1.003
500 m	8	1.028	1.006	1.019	1.004
	4	0.988	1.004	0.979	1.002
	5	0.998	1.006	0.988	1.004
	6	1.008	1.008	0.998	1.006
1,000 m	7	1.017	1.010	1.008	1.008
	8	1.026	1.012	1.017	1.010
	4	0.985	1.011	0.977	1.008
	5	0.995	1.013	0.985	1.010
1,500 m	6	1.005	1.015	0.995	1.012
	7	1.014	1.017	1.005	1.014
	8	1.023	1.019	1.014	1.016
	4	0.982	1.018	0.974	1.016
	5	0.992	1.020	0.983	1.018
	6	1.002	1.022	0.993	1.020
	7	1.011	1.025	1.003	1.023
	8	1.020	1.027	1.011	1.025

#### 4. Performance adjustment after adding freeze and burst prevention solution.

If cooling operation is performed in Winter, or if water inside

the cycle is not removed in the resting phase, you have to add freeze and burst prevention solution to protect from freeze and burst.

Freezer characteristics change by adding freeze and burst prevention solution, so it should be adjusted.

Refer to the following table for the adjustment coefficient after adding freeze and burst prevention solution.

Antifreeze Type	Item	Antifreeze % by wt				
		10 %	20 %	30 %	40 %	50 %
Methanol	Cooling	0.998	0.997	0.995	0.993	0.992
	Heating	0.995	0.990	0.985	0.979	0.974
	Pressure Drop	1.023	1.057	1.091	1.122	1.160
Ethylene glycol	Cooling	0.996	0.991	0.987	0.983	0.979
	Heating	0.993	0.985	0.977	0.969	0.961
	Pressure Drop	1.024	1.068	1.124	1.188	1.263
Propylene glycol	Cooling	0.993	0.987	0.980	0.974	0.968
	Heating	0.966	0.973	0.960	0.948	0.935
	Pressure Drop	1.040	1.098	1.174	1.273	1.405

#### 5. Finalizing the model

As a result of verifying product performance and power consumption considering various adjustment coefficients for the candidate models, if there is no problem, you can finalize it as the final model.

If there is a problem, review again from the candidate model selection stage.

208-230V

Inverter Scroll Chiller		Model	ACAH020VETB	ACAH033VETB	ACAH040VETB	ACAH050VETB	ACAH060VETB
			C/O	C/O	C/O	C/O	C/O
Power		Phase, Lines, V	3, 3, 208-230				
Capacity	kW		65	114	130	171	195
	RT		18.5	32.4	37	48.6	55.4
Input Power	kW		21.7	36.8	43.3	55.2	65.0
Efficiency	W/W		3.00	3.10	3.00	3.10	3.00
IPLV	W/W		5.0	5.1	5.0	5.1	5.0
Sound Pressure	dB(A)		64	66	67	68	69
Compressor	Type	-	Inverter Scroll				
	No. of Compressor	EA	2	4	4	6	6
	Oil Type	-	PVE				
	Oil charge	cc	1,400 x 2	1,400 x 4	1,400 x 4	1,400 x 6	1,400 x 6
Refrigerant	Type	-	R410A				
	Amount of Charged	kg	6.5 x 2	6.5 x 4	6.5 x 4	6.5 x 6	6.5 x 6
Evaporator	Type	-	Shell & Tube				
	Pressure drop	kPa	38.8	29.6	38.8	29.6	38.8
	Operating maximum pressure(Refrigerant / Water)	kg/cm <sup>2</sup>	42/10				
	Water Flow Rate(Standard)	LPM	186	327	372	491	558
	Inlet/Outlet diameter(Water pipe)	mm	50A/50A	65A/65A	65A/65A	65A/65A	65A/65A
Fan motor	Type	-	BLDC				
	No. of Fan	EA	2	4	4	6	6
	No. of Vanes(per fan)	EA	6				
	Air Flow Rate	CMM	246 x 2 @1,000rpm	246 x 4 @1,000rpm	246 x 4 @1,000rpm	246 x 6 @1,000rpm	246 x 6 @1,000rpm
	Motor power	W	900 x 2	900 x 4	900 x 4	900 x 6	900 x 6
Expansion unit		-	EEV				
Weight		kg	560	1,034	1,034	1,522	1,522
Dimension	W	mm	765	1,528	1,528	2,291	2,291
	H	mm	2,200				
	D	mm	2,154				
Footprint		m <sup>2</sup> /RT	0.089	0.102	0.089	0.101	0.089
Protection Devices	High/Low Pressure	-	0				
	Anti Frost	-	0				
Remote Control		-	Modbus				
Outlet Temperature		°C	4-20				
Ambient Temperature		°C	-15-48				
Guaranteed Load Capacity Range		-	20 % - 100 %				

Note:  
 1. Due to our policy of innovation some specifications may be changed without prior notification.  
 2. Capacities and Inputs are based on the following conditions.  
 Cooling : Outdoor air temp. 35°C, Water inlet temp. 12°C, Water Outlet temp. 7°C  
 3. The AHRI Certified® mark indicates LG Electronics participation in the AHRI Certification program. For verification of individual certified products, go to [www.ahridirectory.org](http://www.ahridirectory.org).  
 4. The ACAH\*\*\*VETB / ACAH\*\*\*HETB models are certified by AHRI to AHRI Standard 550/590.

380V

Inverter Scroll Chiller		Model	ACAH020LETB	ACAH023LETB	ACAH033LETB	ACAH040VETB
			C/O	C/O	C/O	C/O
Power		Phase, Lines, V	3, 4, 380-415			
Capacity	kW		65	74	114	130
	RT		18.5	21.0	32.4	37.0
Input Power	kW		21.5	28.5	36.2	43.0
Efficiency	W/W		3.02	2.60	3.15	3.02
IPLV	W/W		5.3	5.1	5.4	5.3
Sound Pressure	dB(A)		64	66	66	67
Compressor	Type	-	Inverter Scroll			
	No. of Compressor	EA	2	2	4	4
	Oil Type	-	PVE			
	Oil charge	cc	1,400 x 2	1,400 x 2	1,400 x 4	1,400 x 4
Refrigerant	Type	-	R410A			
	Amount of Charged	kg	6.5 x 2	6.5 x 2	6.5 x 4	6.5 x 4
Evaporator	Type	-	Shell & Tube			
	Pressure drop	kPa	38.8	49.2	29.6	38.8
	Operating maximum pressure(Refrigerant / Water)	kg/cm <sup>2</sup>	42/10			
	Water Flow Rate(Standard)	LPM	186	211	327	372
	Inlet/Outlet diameter(Water pipe)	mm	50A/50A	50A/50A	65A/65A	65A/65A
Fan motor	Type	-	BLDC			
	No. of Fan	EA	2	2	4	4
	No. of Vanes(per fan)	EA	6			
	Air Flow Rate	CMM	246 x 2 @1,000rpm	246 x 2 @1,000rpm	246 x 4 @1,000rpm	246 x 4 @1,000rpm
	Motor power	W	900 x 2	900 x 2	900 x 4	900 x 4
Expansion unit		-	EEV			
Weight		kg	560	560	1,034	1,034
Dimension	W	mm	765	765	1,528	1,528
	H	mm	2,200			
	D	mm	2,154			
Footprint		m <sup>2</sup> /RT	0.089	0.078	0.102	0.089
Protection Devices	High/Low Pressure	-	0			
	Anti Frost	-	0			
Remote Control		-	Modbus			
Outlet Temperature		°C	4-20			
Ambient Temperature		°C	-15-48			
Guaranteed Load Capacity Range		-	20 % - 100 %			

Note:  
 1. Due to our policy of innovation some specifications may be changed without prior notification.  
 2. Capacities and Inputs are based on the following conditions.  
 Cooling : Outdoor air temp. 35°C, Water inlet temp. 12°C, Water Outlet temp. 7°C  
 3. The AHRI Certified® mark indicates LG Electronics participation in the AHRI Certification program. For verification of individual certified products, go to [www.ahridirectory.org](http://www.ahridirectory.org).  
 4. The ACAH\*\*\*VETB / ACAH\*\*\*HETB models are certified by AHRI to AHRI Standard 550/590.



380V

Inverter Scroll Chiller		Model	ACAH045LETB	ACAH050LETB	ACAH060LETB	ACAH067LETB
			C/O	C/O	C/O	C/O
Power		Phase, Lines, V	3, 4, 380-415			
Capacity	kW		148	171	195	222
	RT		42.1	48.6	55.4	63.1
Input Power	kW		56.9	54.3	64.6	85.4
Efficiency	W/W		2.60	3.15	3.02	2.60
IPLV	W/W		5.1	5.4	5.3	5.1
Sound Pressure	dB(A)		69	68	69	71
Compressor	Type	-	Inverter Scroll			
	No. of Compressor	EA	4	6	6	6
	Oil Type	-	PVE			
	Oil charge	cc	1,400 x 4	1,400 x 6	1,400 x 6	1,400 x 6
Refrigerant	Type	-	R410A			
	Amount of Charged	kg	6.5 x 4	6.5 x 6	6.5 x 6	6.5 x 6
Evaporator	Type	-	Shell & Tube			
	Pressure drop	kPa	49.2	29.6	38.8	49.2
	Operating maximum pressure(Refrigerant / Water)	kg/cm <sup>2</sup>	42/10			
	Water Flow Rate(Standard)	LPM	422	491	558	633
	Inlet/Outlet diameter(Water pipe)	mm	65A/65A			
Fan motor	Type	-	BLDC			
	No. of Fan	EA	4	6	6	6
	No. of Vanes(per fan)	EA	6			
	Air Flow Rate	CMM	246 x 4 @1,000rpm	246 x 6 @1,000rpm	246 x 6 @1,000rpm	246 x 6 @1,000rpm
	Motor power	W	900 x 4	900 x 6	900 x 6	900 x 6
Expansion unit		-	EEV			
Weight		kg	1,034	1,522	1,522	1,522
Dimension	W	mm	1,528	2,291	2,291	2,291
	H	mm	2,200			
	D	mm	2,154			
Footprint		m <sup>2</sup> /RT	0.078	0.101	0.089	0.078
Protection Devices	High/Low Pressure	-	0			
	Anti Frost	-	0			
Remote Control		-	Modbus			
Outlet Temperature		°C	4~20			
Ambient Temperature		°C	-15~48			
Guaranteed Load Capacity Range		-	20 % ~ 100 %			

Note:  
 1. Due to our policy of innovation some specifications may be changed without prior notification.  
 2. Capacities and Inputs are based on the following conditions.  
 Cooling : Outdoor air temp. 35°C, Water inlet temp. 12°C, Water Outlet temp. 7°C  
 3. The AHRI Certified® mark indicates LG Electronics participation in the AHRI Certification program. For verification of individual certified products, go to [www.ahridirectory.org](http://www.ahridirectory.org).  
 4. The ACAH\*\*\*VETB / ACAH\*\*\*HETB models are certified by AHRI to AHRI Standard 550/590.

460V

Inverter Scroll Chiller		Model	ACAH020HETB	ACAH023HETB	ACAH033HETB	ACAH040HETB
			C/O	C/O	C/O	C/O
Power		Phase, Lines, V	3, 3, 460			
Capacity	kW		65	74	114	130
	RT		18.5	21.0	32.4	37.0
Input Power	kW		21.5	28.5	36.2	43.0
Efficiency	W/W		3.02	2.60	3.15	3.02
IPLV	W/W		5.3	5.1	5.4	5.3
Sound Pressure	dB(A)		64	66	66	67
Compressor	Type	-	Inverter Scroll			
	No. of Compressor	EA	2	2	4	4
	Oil Type	-	PVE			
	Oil charge	cc	1,400 x 2	1,400 x 2	1,400 x 4	1,400 x 4
Refrigerant	Type	-	R410A			
	Amount of Charged	kg	6.5 x 2	6.5 x 2	6.5 x 4	6.5 x 4
Evaporator	Type	-	Shell & Tube			
	Pressure drop	kPa	38.8	49.2	29.6	38.8
	Operating maximum pressure(Refrigerant / Water)	kg/cm <sup>2</sup>	42/10			
	Water Flow Rate(Standard)	LPM	186	211	327	372
	Inlet/Outlet diameter(Water pipe)	mm	50A/50A	50A/50A	65A/65A	65A/65A
Fan motor	Type	-	BLDC			
	No. of Fan	EA	2	2	4	4
	No. of Vanes(per fan)	EA	6			
	Air Flow Rate	CMM	246 x 2 @1,000rpm	246 x 2 @1,000rpm	246 x 4 @1,000rpm	246 x 4 @1,000rpm
	Motor power	W	900 x 2	900 x 2	900 x 4	900 x 4
Expansion unit		-	EEV			
Weight		kg	560	560	1,034	1,034
Dimension	W	mm	765	765	1,528	1,528
	H	mm	2,200			
	D	mm	2,154			
Footprint		m <sup>2</sup> /RT	0.089	0.078	0.102	0.089
Protection Devices	High/Low Pressure	-	0			
	Anti Frost	-	0			
Remote Control		-	Modbus			
Outlet Temperature		°C	4~20			
Ambient Temperature		°C	-15~48			
Guaranteed Load Capacity Range		-	20 % ~ 100 %			

Note:  
 1. Due to our policy of innovation some specifications may be changed without prior notification.  
 2. Capacities and Inputs are based on the following conditions.  
 Cooling : Outdoor air temp. 35°C, Water inlet temp. 12°C, Water Outlet temp. 7°C  
 3. The AHRI Certified® mark indicates LG Electronics participation in the AHRI Certification program. For verification of individual certified products, go to [www.ahridirectory.org](http://www.ahridirectory.org).  
 4. The ACAH\*\*\*VETB / ACAH\*\*\*HETB models are certified by AHRI to AHRI Standard 550/590.

460V

Inverter Scroll Chiller		Model	ACAH045HETB	ACAH050HETB	ACAH060HETB	ACAH067HETB
			C/O	C/O	C/O	C/O
Power		Phase, Lines, V	3, 3, 460			
Capacity	kW		148	171	195	222
	RT		42.1	48.6	55.4	63.1
Input Power	kW		56.9	54.3	64.6	85.4
Efficiency	W/W		2.60	3.15	3.02	2.60
IPLV	W/W		5.1	5.4	5.3	5.1
Sound Pressure	dB(A)		69	68	69	71
Compressor	Type	-	Inverter Scroll			
	No. of Compressor	EA	4	6	6	6
	Oil Type	-	PVE			
	Oil charge	cc	1,400 x 4	1,400 x 6	1,400 x 6	1,400 x 6
Refrigerant	Type	-	R410A			
	Amount of Charged	kg	6.5 x 4	6.5 x 6	6.5 x 6	6.5 x 6
Evaporator	Type	-	Shell & Tube			
	Pressure drop	kPa	49.2	29.6	38.8	49.2
	Operating maximum pressure(Refrigerant / Water)	kg/cm <sup>2</sup>	42/10			
	Water Flow Rate(Standard)	LPM	422	491	558	633
	Inlet/Outlet diameter(Water pipe)	mm	65A/65A			
Fan motor	Type	-	BLDC			
	No. of Fan	EA	4	6	6	6
	No. of Vanes(per fan)	EA	6			
	Air Flow Rate	CMM	246 x 4 @1,000rpm	246 x 6 @1,000rpm	246 x 6 @1,000rpm	246 x 6 @1,000rpm
	Motor power	W	900 x 4	900 x 6	900 x 6	900 x 6
Expansion unit	-	EEV				
Weight	kg	1,034	1,522	1,522	1,522	
Dimension	W	mm	1,528	2,291	2,291	2,291
	H	mm	2,200			
	D	mm	2,154			
Footprint	m <sup>2</sup> /RT	0.078	0.101	0.089	0.078	
Protection Devices	High/Low Pressure	-	0			
	Anti Frost	-	0			
Remote Control	-	Modbus				
Outlet Temperature	°C	4~20				
Ambient Temperature	°C	-15~48				
Guaranteed Load Capacity Range	-	20 % ~ 100 %				

Note:  
 1. Due to our policy of innovation some specifications may be changed without prior notification.  
 2. Capacities and Inputs are based on the following conditions.  
 Cooling : Outdoor air temp. 35°C, Water inlet temp. 12°C, Water Outlet temp. 7°C  
 3. The AHRI Certified® mark indicates LG Electronics participation in the AHRI Certification program. For verification of individual certified products, go to www.ahridirectory.org.  
 4. The ACAH\*\*\*VETB / ACAH\*\*\*HETB models are certified by AHRI to AHRI Standard 550/590.

380-415V

Inverter Scroll Chiller		Model	ACHH020LETB	ACHH023LETB	ACHH033LETB	ACHH040LETB	ACHH045LETB
			1 Unit		2 Unit		
Power		Ph, Lines, V	3, 4, 380-415				
Capacity	Cooling	kW	65	74	114	130	148
		RT	18.5	21.0	32.4	37.0	42.1
	Heating	kW	70	80	120	140	160
		RT	19.9	22.7	34.1	39.8	45.5
Input Power	Cooling	kW	21.50	28.50	36.2	43.0	56.9
	Heating	kW	23.00	28.10	38.1	45.9	56.1
Efficiency	Cooling	W/W	3.02	2.60	3.15	3.02	2.60
	Heating	W/W	3.05	2.85	3.15	3.05	2.85
IPLV	W/W		5.3	5.1	5.4	5.3	5.1
Sound Pressure	dB(A)		63	65	65	66	68
Compressor	Type	-	Scroll				
	No. of Compressor	EA	2	2	4	4	4
	Oil Type	-	PVE				
	Oil charge	cc	1,400 x 2		1,400 x 4		
Refrigerant	Type	-	R410A				
	Amount of Charged	kg	6.7 X 2		6.7 X 4		
Evaporator	Type	-	Shell & Tube				
	Operating maximum pressure	kg/cm <sup>2</sup>	42 / 10				
	Standard Flow(Cooling/Heating)	LPM	186 / 200	211 / 229	327 / 345	372 / 400	422 / 458
	Inlet/Outlet diameter(Water pipe)	mm	50A / 50A		65A / 65A		
Expansion unit	-	EEV					
Weight	kg	580		1,080			
Dimension	W	mm	765		1,528		
	H	mm	2,293				
	D	mm	2,154				
Remote Control	-	Modbus					
Outlet Temperature	Cooling	°C	4~20				
	Heating	°C	30~55				
Ambient Temperature	Cooling	°C	-15~48				
	Heating	°C	-30~35				
Earth Leakage Breaker	A	60	60	100	100	125	

Note:  
 1. Due to our policy of innovation some specifications may be changed without prior notification.  
 2. Capacities and Inputs are based on the following conditions.  
 Cooling : Outdoor air temp. 35°C, Water inlet temp. 12°C, Water Outlet temp. 7°C Heating : Outdoor air temp. 7°C, Water inlet temp. 40°C, Water Outlet temp. 45°C  
 3. Sound pressure level is measured on the rated condition in the anechoic rooms by ISO 3745 standard.

## Cooling only

ACAH	Unit		Power Supply		COMP		OFM	
	Voltage	Voltage range	MCA	MFA	MSC	RLA	kW	FLA
020VETB	208 - 230	Min: 187, Max: 253	72.9	100	20.4	57.5	1.8	8
033VETB	208 - 230	Min: 187, Max: 253	117.4	125	40.8	95.2	3.6	16
040VETB	208 - 230	Min: 187, Max: 253	138.4	150	40.8	115.0	3.6	16
050VETB	208 - 230	Min: 187, Max: 253	117.4+61.8	125+80	40.7+20.4	95.2+47.6	3.6+1.8	16+8
060VETB	208 - 230	Min: 187, Max: 253	138.4+72.9	150+100	40.7+20.4	115.0+57.5	3.6+1.8	16+8
020LETB	380 - 415	Min: 342, Max: 456	39	60	11.8	30.2	1.8	5
023LETB	380 - 415	Min: 342, Max: 456	48	60	11.8	38.2	1.8	5
033LETB	380 - 415	Min: 342, Max: 456	72	100	23.6	55.2	3.6	10
040LETB	380 - 415	Min: 342, Max: 456	78	100	23.6	60.4	3.6	10
045LETB	380 - 415	Min: 342, Max: 456	96	125	23.6	76.4	3.6	10
050LETB	380 - 415	Min: 342, Max: 456	108	125	35.4	82.8	5.4	15
060LETB	380 - 415	Min: 342, Max: 456	117	125	35.4	90.6	5.4	15
067LETB	380 - 415	Min: 342, Max: 456	144	200	35.4	114.6	5.4	15
020HETB	460	Min: 414, Max: 506	31.0	50	9.7	24.9	1.8	5
023HETB	460	Min: 414, Max: 506	41.2	50	9.7	31.6	1.8	5
033HETB	460	Min: 414, Max: 506	48.4	60	19.5	45.6	3.6	10
040HETB	460	Min: 414, Max: 506	59.0	80	19.5	49.9	3.6	10
045HETB	460	Min: 414, Max: 506	78.2	100	19.5	63.1	3.6	10
050HETB	460	Min: 414, Max: 506	71.4	100	29.2	68.4	5.4	15
060HETB	460	Min: 414, Max: 506	87.0	125	29.2	74.8	5.4	15
067HETB	460	Min: 414, Max: 506	115.2	150	29.2	94.7	5.4	15

## Heat pump

ACHH	Unit			Power Supply		COMP		OFM	
	Hz	Volt	Voltage Range	MCA	MFA	MSC	RLA	kW	FLA
020LETB	60	380-415	Min:342, Max:456	39	60	11.8	30.3	1.8	5
023LETB	60	380-415	Min:342, Max:456	48	60	11.8	39.0	1.8	5
033LETB	60	380-415	Min:342, Max:456	72	100	23.6	56.6	3.6	10
040LETB	60	380-415	Min:342, Max:456	78	100	23.6	60.6	3.6	10
045LETB	60	380-415	Min:342, Max:456	96	125	23.6	78.0	3.6	10

MCA: Minimum Circuit Ampere, A  
MFA: Maximum Fuse Ampere, A  
RLA: Rated Load Ampere, A  
MSC: Maximum Start Current, A

**Note:**

1. RLA is the current required when operated in the following condition. Cooling : Outdoor air temp. 27°C DB / 19.0°C WB, Water inlet / Outlet temp. 12°C / 7°C Heating : Outdoor air temp. 7°C DB / 6.0°C WB, Water inlet / Outlet temp. 40.0°C / 45.0°C
  2. Voltage range  
The chiller must be operated at the voltage within the upper and lower limit supplied from the power terminal to operate normally.
  3. Maximum voltage variance permitted between phases is 2%.
  4. MCA is the criteria of selecting the wiring standard.
  5. MFA is used when selecting circuit breaker and grounding error circuit breaker(Electricity leakage circuit breaker).
- \* For Russia only, MCA of ACAH033LETB is 76.

## ACAH Series 1 Unit

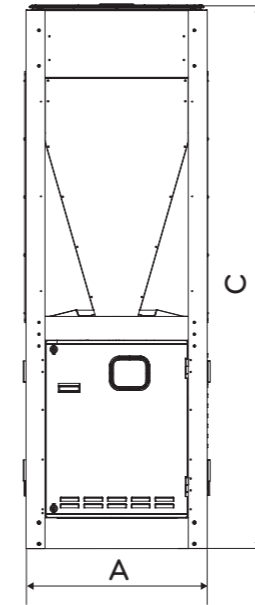

Front view

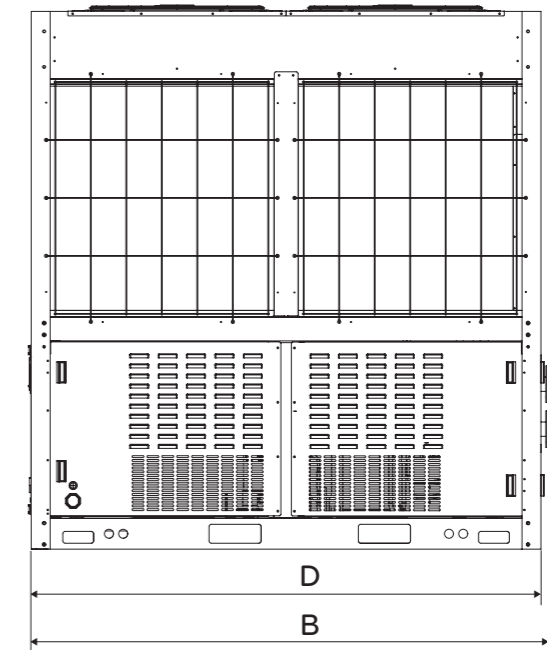

Side view

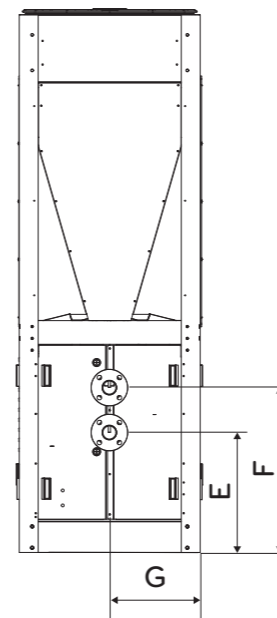

Rear view

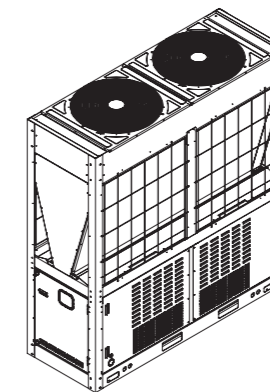

(Unit : mm)

Classification	Dimension
A	765
B	2,198
C	2,200
D	2,154
E	507
F	700
G	384



# Outline dimension



## ACAH Series 2 Unit

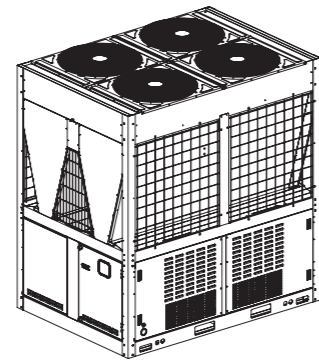
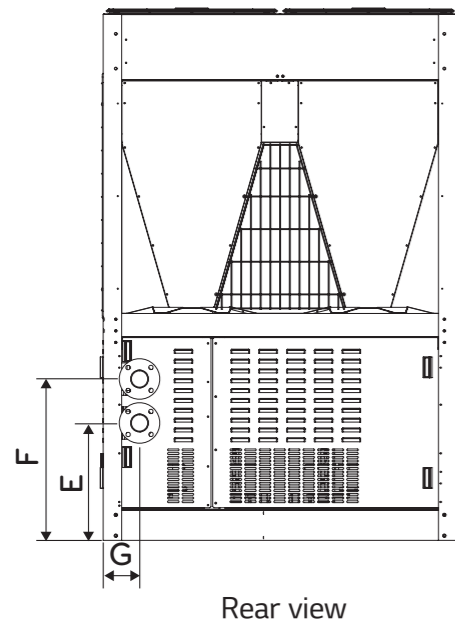
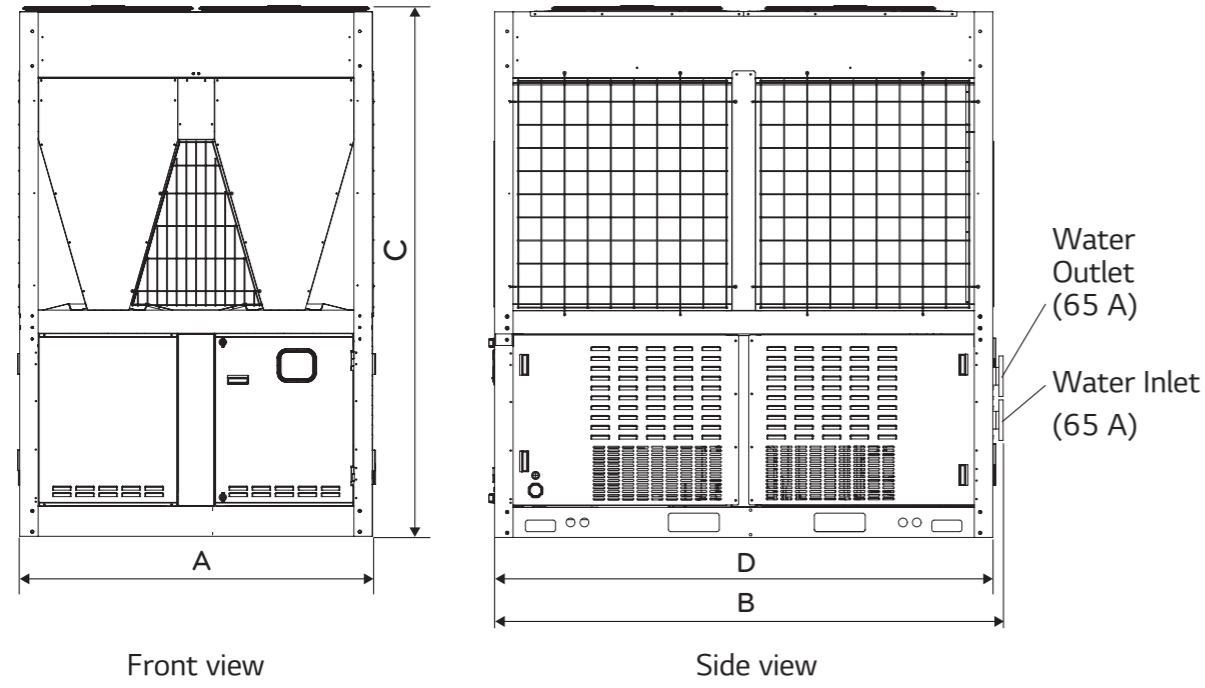

(Unit : mm)

Classification	Dimension
A	1,528
B	2,199
C	2,200
D	2,154
E	434
F	700
G	157

# Outline dimension



## ACAH Series 3 Unit

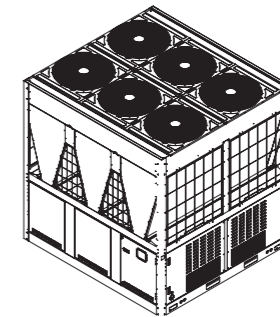
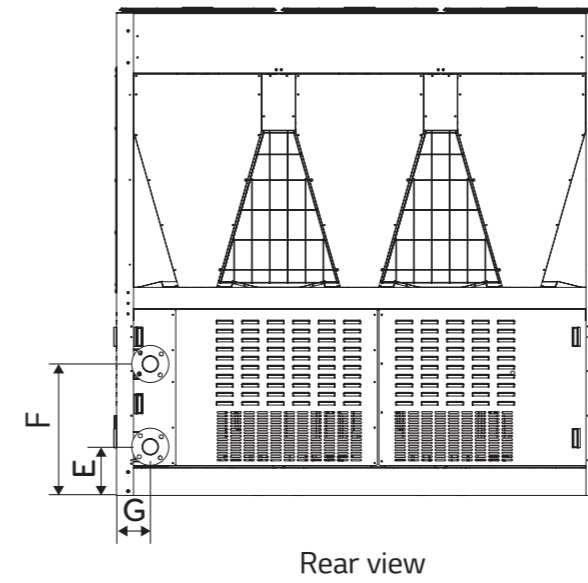
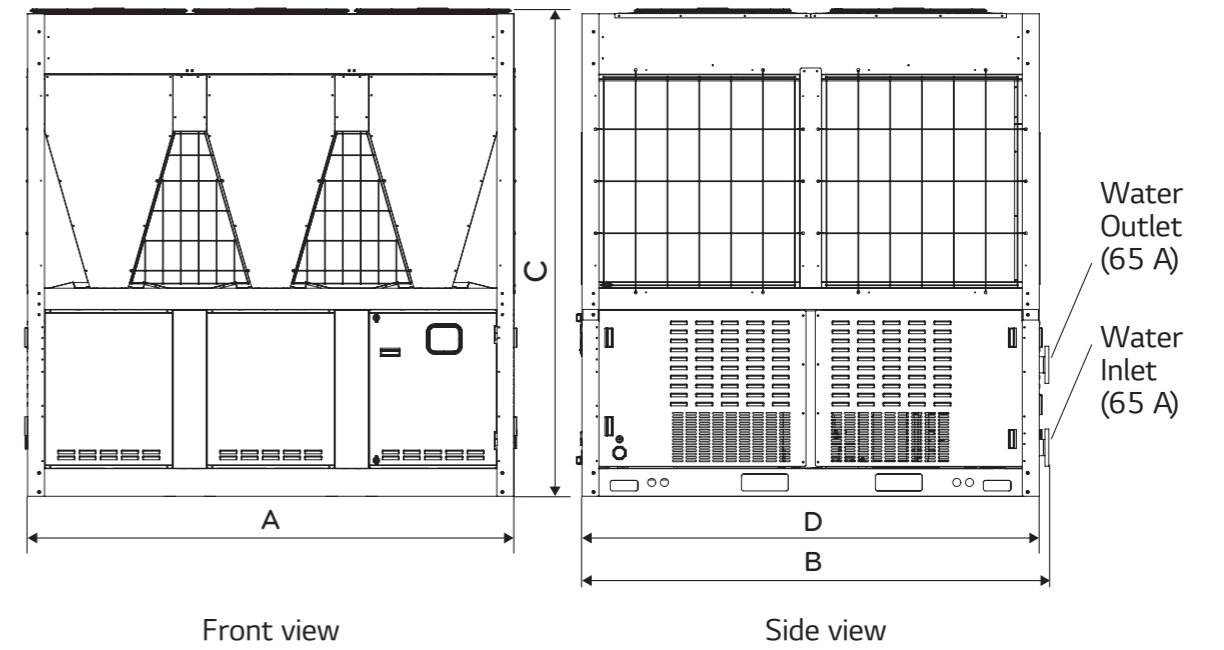

(Unit : mm)

Classification	Dimension
A	2,291
B	2,199
C	2,200
D	2,154
E	434
F	700
G	157

# Outline dimension



## ACHH Series 1 Unit

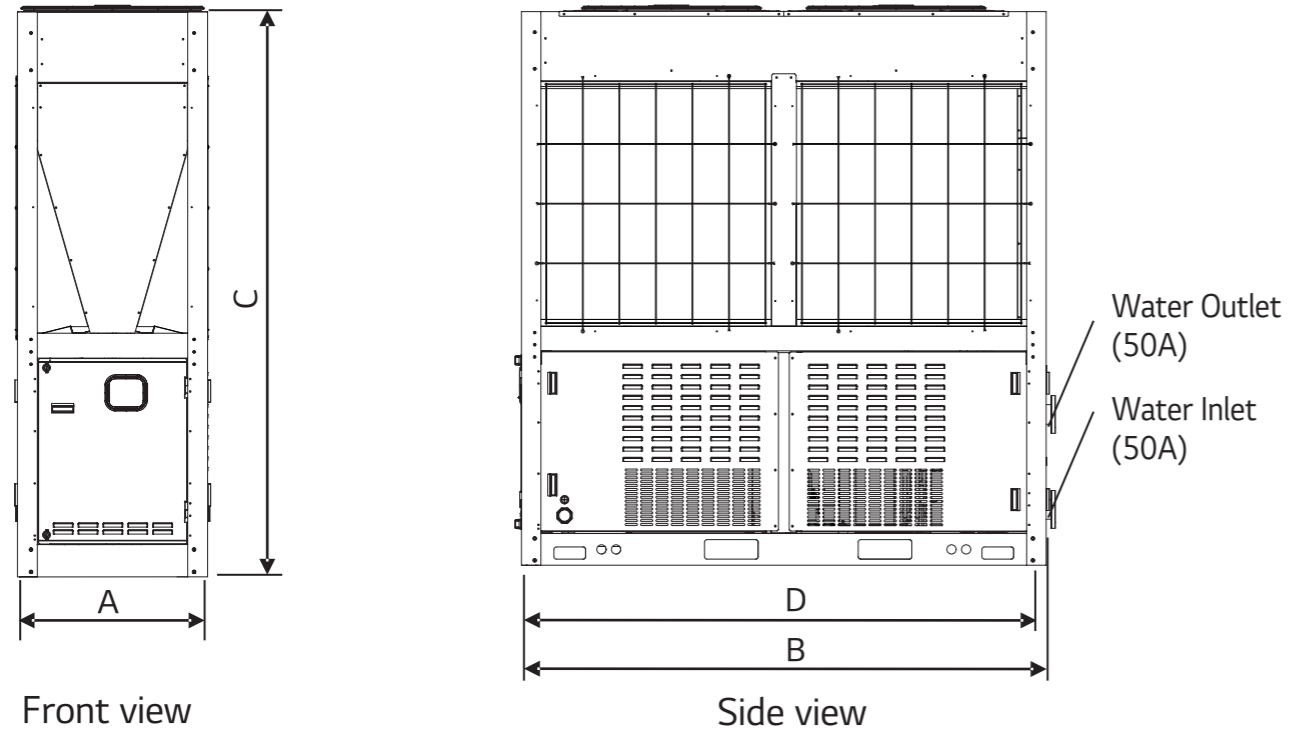

# Outline dimension



## ACHH Series 2 Unit

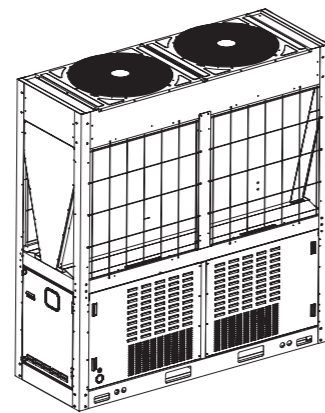
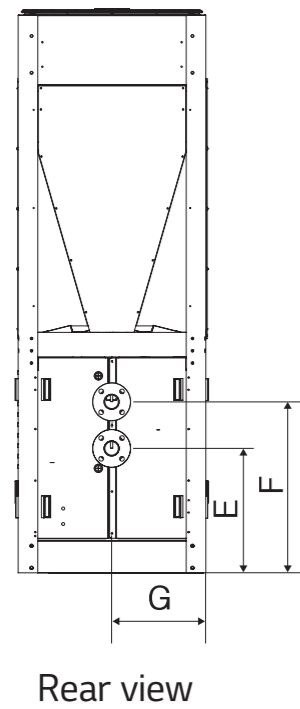
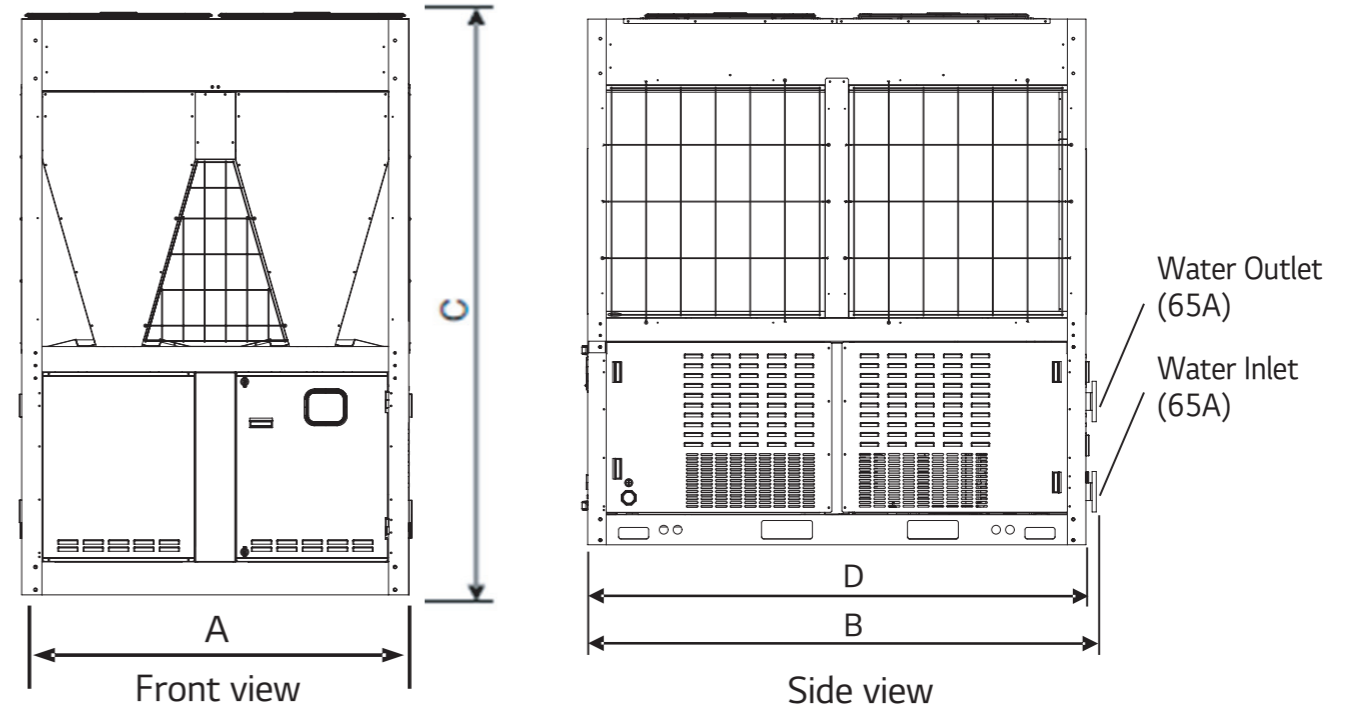

(Unit : mm)

Classification	Dimension
A	765
B	2,198
C	2,293
D	2,154
E	507
F	700
G	384

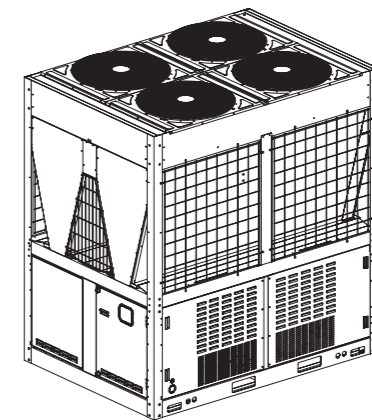
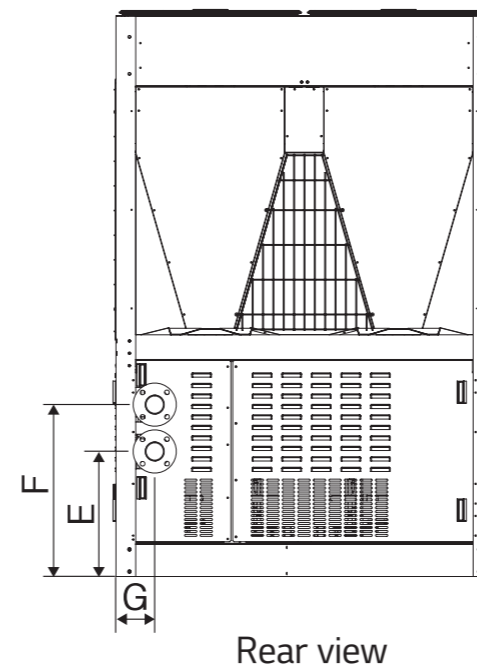

(Unit : mm)

Classification	Dimension
A	1,528
B	2,198
C	2,293
D	2,154
E	434
F	700
G	157

## Details to consider when installing the base

- The base must be able to withstand concentrated load.
- The base must be installed with maximum gradient of 1/300.
- The height of the base must be higher than the surface of the water and drain holes must be installed around.
- Set the height of the base according to the installation environment so that the product is not submersed in water.  
The default height of the base is 200mm and it must be at least doubled in areas with double the snowfall of 100mm or above.
- Install the drain pipe in the drain hole.
- The drainage must be finished so that particles around the drainage do not clog the pipes.
- LG is not responsible for product failure or damage from incorrectly designed or manufactured base.

## Shape of anchor bolt

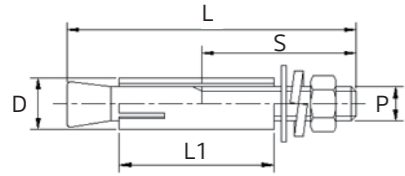

## Specification of anchor bolt

Screw size(d)	L	S	D	L1	Used drill	Depth of drill(min.)	Pullout load(N)
15.88mm(M16)	125	70	22	65	22	65	42,140

## Dimension

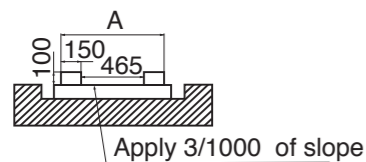
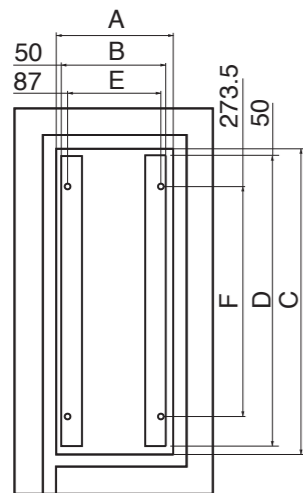

1 Unit Drawing of base

## Shape of anchor bolt

(Unit: mm)

	1 Unit	2 Unit	3 Unit
A	865	1,630	2,391
B	765	1,528	2,291
C	2,254	2,254	2,254
D	2,154	2,154	2,154
E	691	1,456	2,217
F	1,707	1,707	1,707

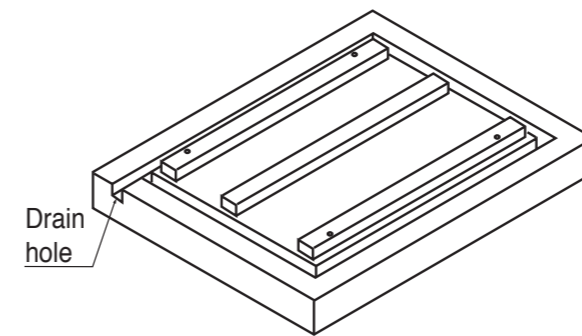
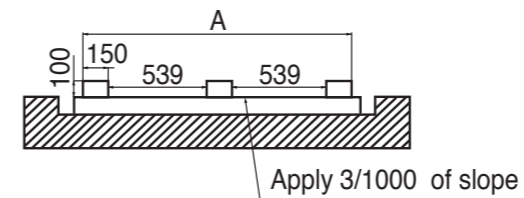
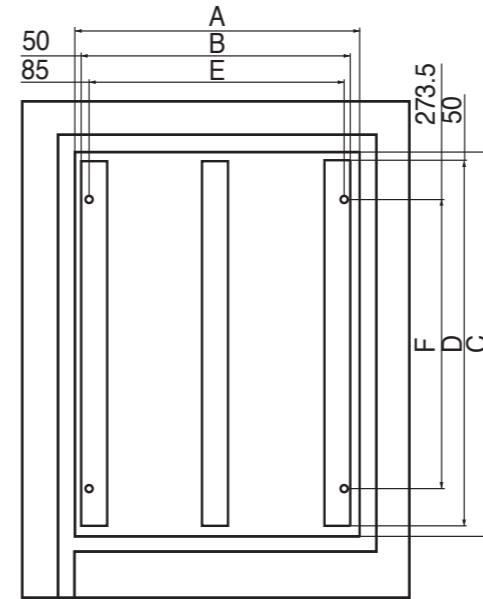
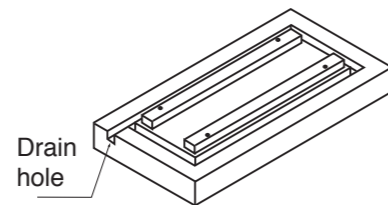

2 Unit Drawing of base

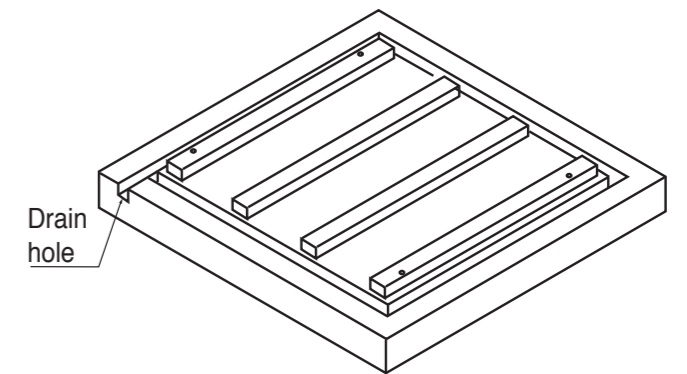
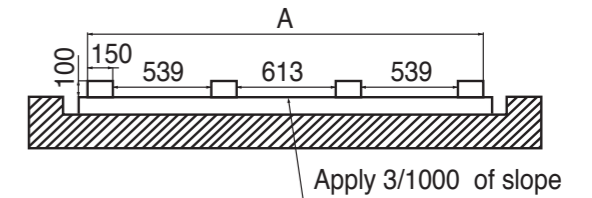
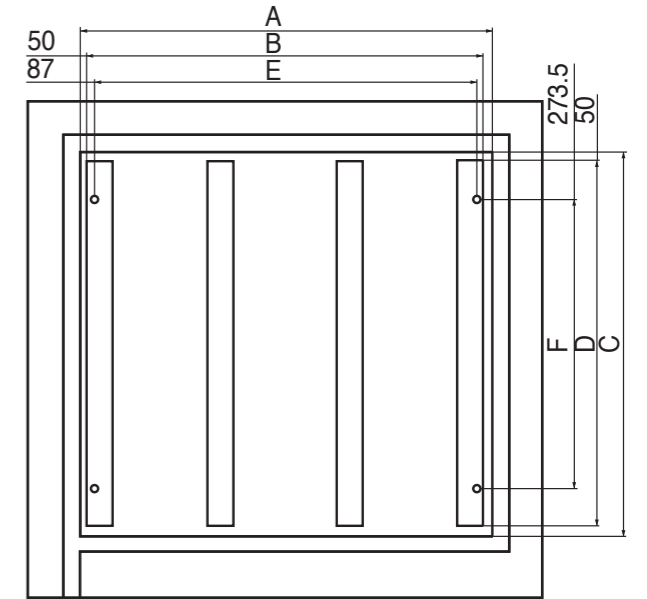

3 Unit Drawing of base



# Piping diagram

ACAH Series 1 Unit

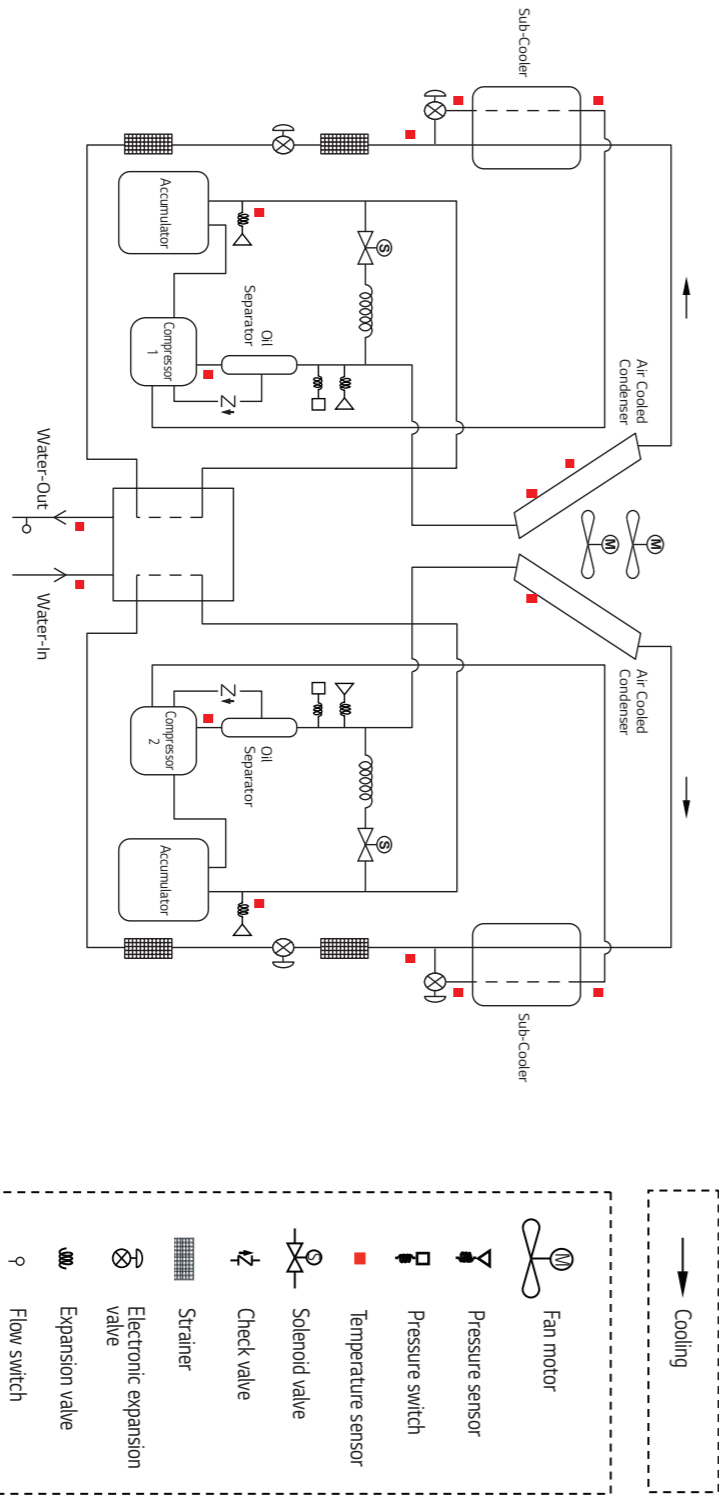

# Piping diagram

ACAH Series 2 Unit

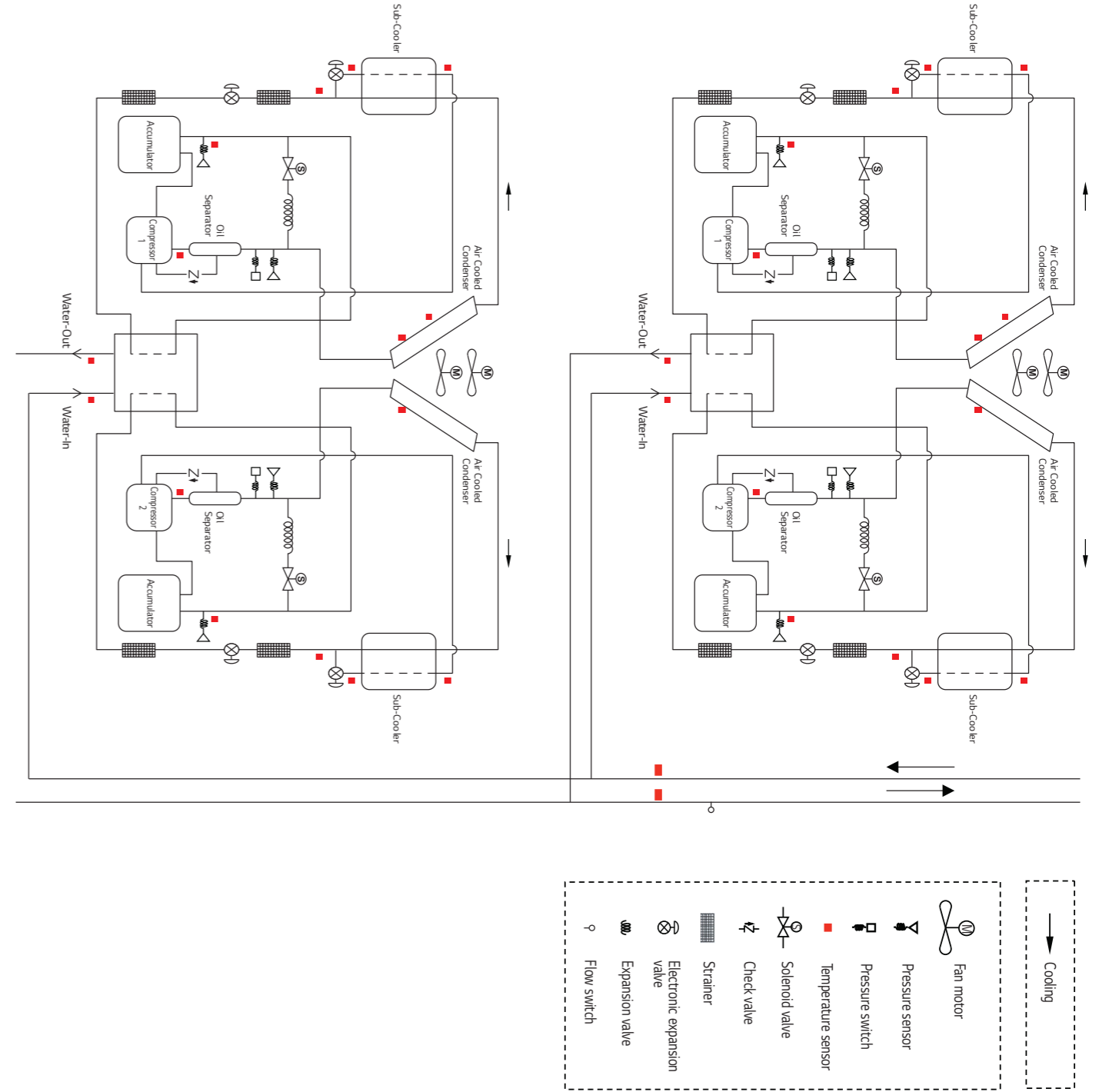

## ACAH Series 3 Unit

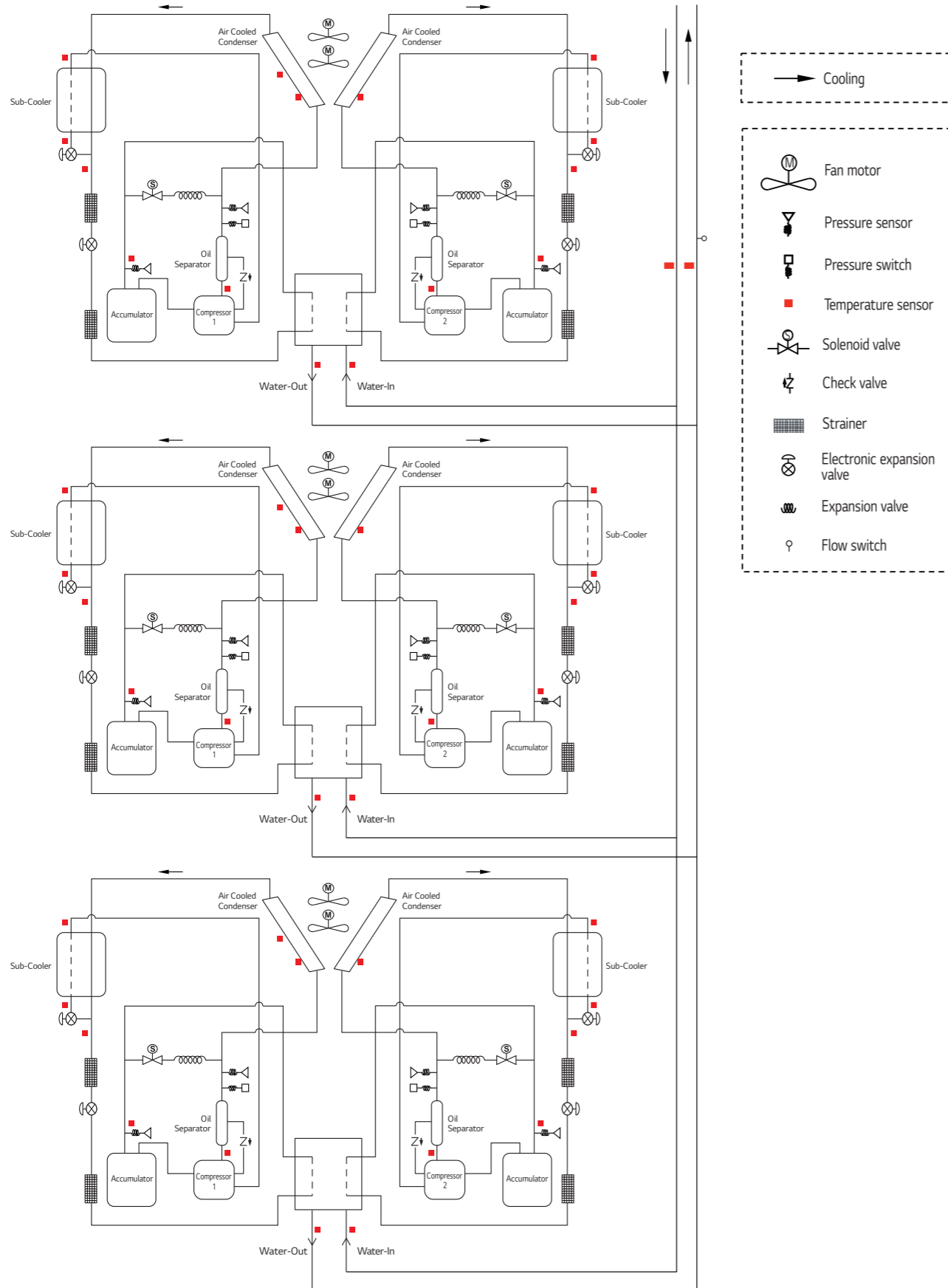

## ACHH Series 1 Unit

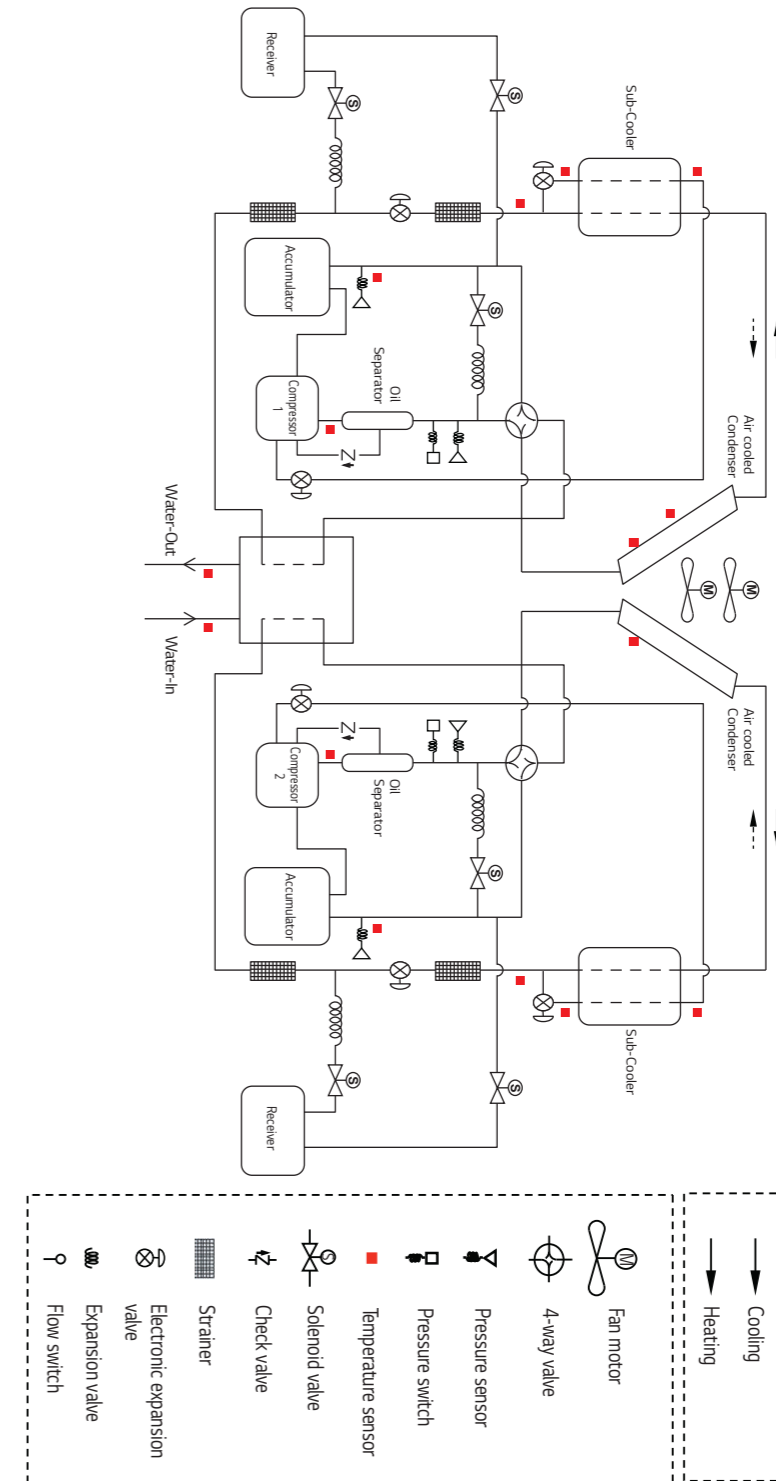

## ACHH Series 2 Unit

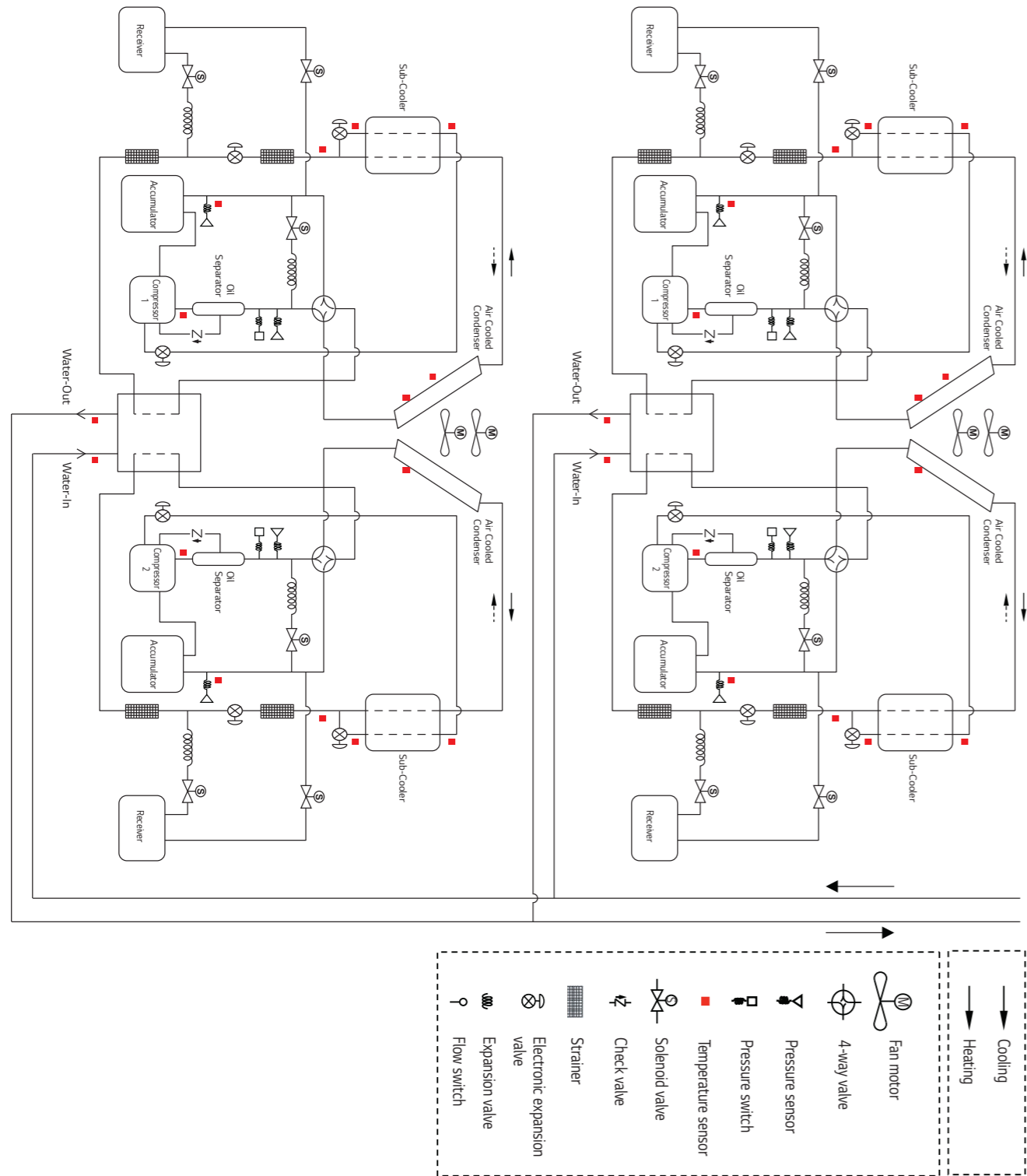

## 1 Unit, 2 Unit(Main), 3 Unit(Main)

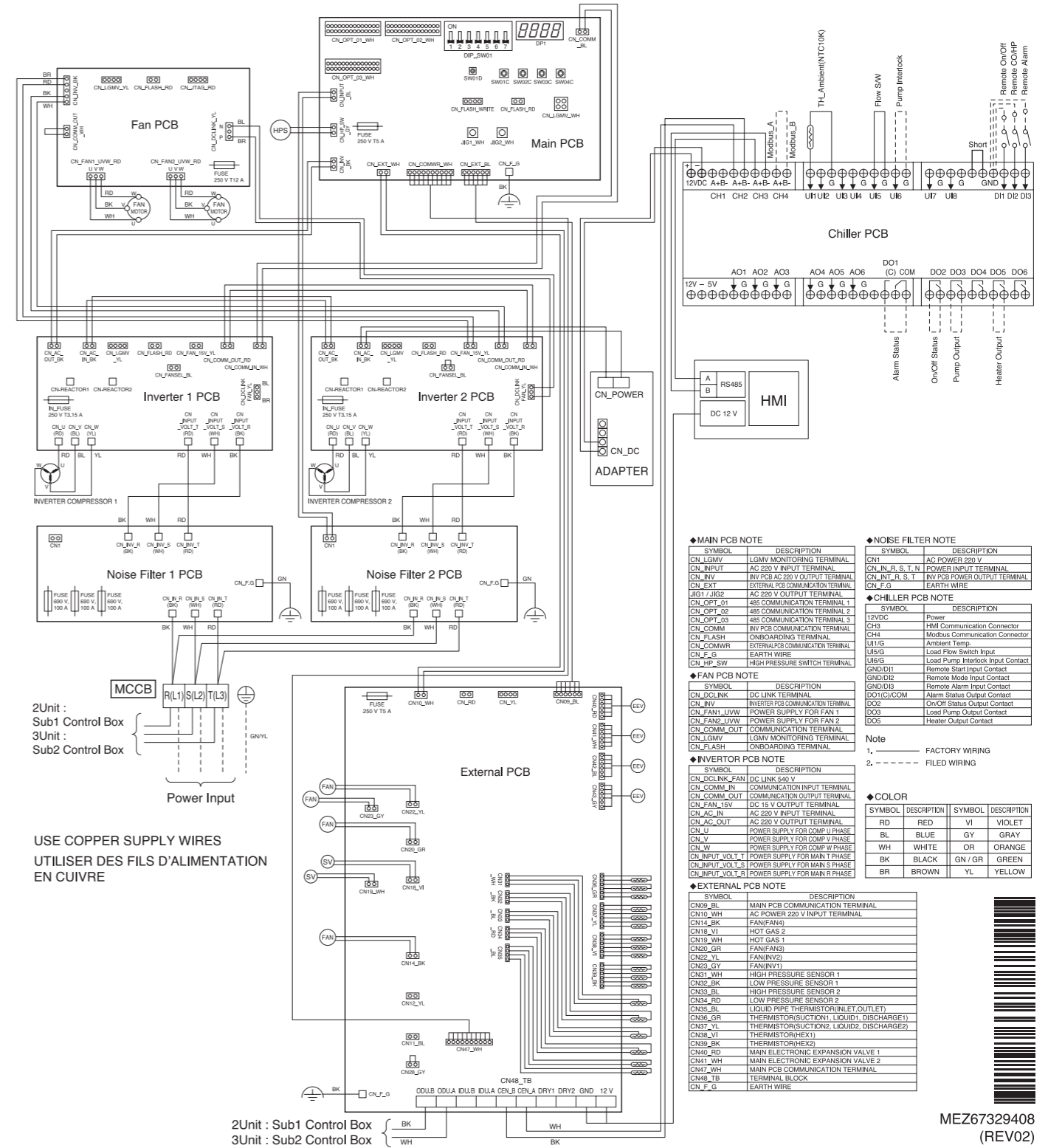



## 1 Unit, 2 Unit(Main), 3 Unit(Main)

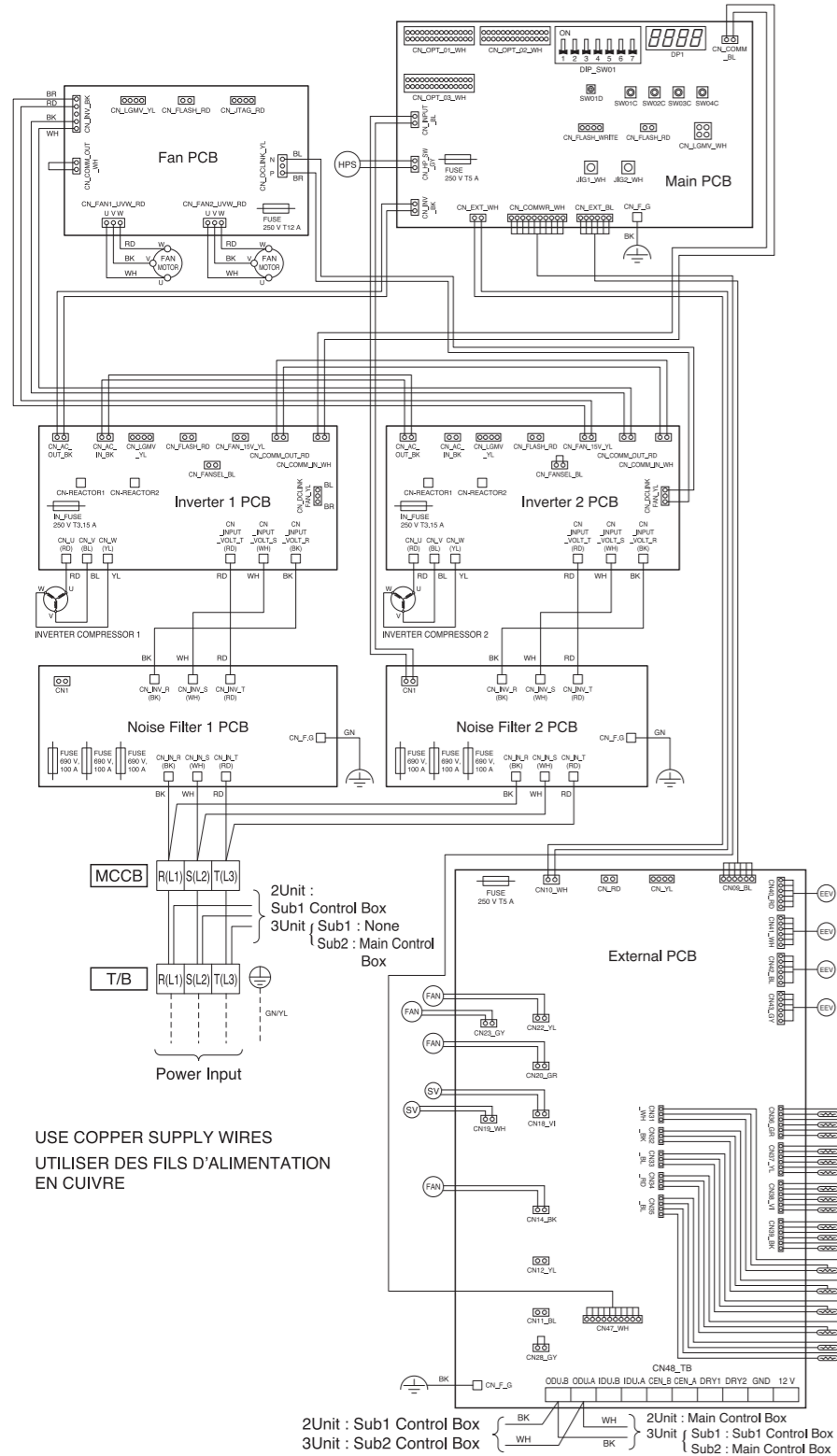

SYMBOL	DESCRIPTION	SYMBOL	DESCRIPTION
CN_LGMV	LGMV MONITORING TERMINAL	CN1	AC POWER 220 V
CN_INV	AC 220 V INPUT TERMINAL	CN_IN_R, S, T, N	AC POWER INPUT TERMINAL
CN_INVV	INV PCB AC 220 V OUTPUT TERMINAL	CN_INT_R, S, T, N	INV PCB POWER OUTPUT TERMINAL
CN_EXT	EXTERNAL PCB COMMUNICATION TERMINAL	CN_F_G	EARTH WIRE
JIG1 / JIG2	AC 220 V OUTPUT TERMINAL		
CN_OPT_01	485 COMMUNICATION TERMINAL 1		
CN_OPT_02	485 COMMUNICATION TERMINAL 2		
CN_OPT_03	485 COMMUNICATION TERMINAL 3		
CN_COMM	INV PCB COMMUNICATION TERMINAL		
CN_FLASH	ONBOARDING TERMINAL		
CN_COMMR	EXTERNAL PCB COMMUNICATION TERMINAL		
CN_F_G	EARTH WIRE		
CN_HP_SW	HIGH PRESSURE SWITCH TERMINAL		

SYMBOL	DESCRIPTION	SYMBOL	DESCRIPTION
CN_DCLINK	DC LINK TERMINAL	RD	RED VI VIOLET
CN_INV	INVERTER PCB COMMUNICATION TERMINAL	BL	BLUE GY GRAY
CN_FAN1_UVW	POWER SUPPLY FOR FAN 1	WH	WHITE OR ORANGE
CN_FAN2_UVW	POWER SUPPLY FOR FAN 2	BK	BLACK GN / GR GREEN
CN_COMM_OUT	COMMUNICATION TERMINAL	BR	BROWN YL YELLOW
CN_FLASH	ONBOARDING TERMINAL		

SYMBOL	DESCRIPTION	SYMBOL	DESCRIPTION
CN_DCLINK_FAN	DC LINK 540 V		
CN_COMM_IN	COMMUNICATION INPUT TERMINAL		
CN_COMM_OUT	COMMUNICATION OUTPUT TERMINAL		
CN_FAN_15V	DC 15 V OUTPUT TERMINAL		
CN_AC_IN	AC 220 V INPUT TERMINAL		
CN_AC_OUT	AC 220 V OUTPUT TERMINAL		
CN_U	POWER SUPPLY FOR COMP U PHASE		
CN_V	POWER SUPPLY FOR COMP V PHASE		
CN_W	POWER SUPPLY FOR COMP W PHASE		
CN_INPUT_VOLT_S	POWER SUPPLY FOR MAIN S PHASE		
CN_INPUT_VOLT_R	POWER SUPPLY FOR MAIN R PHASE		

SYMBOL	DESCRIPTION	SYMBOL	DESCRIPTION
CN09_BL	MAIN PCB COMMUNICATION TERMINAL		
CN10_WH	AC POWER 220 V INPUT TERMINAL		
CN14_BK	FAN(FAN4)		
CN18_VI	HOT GAS 2		
CN19_WH	HOT GAS 1		
CN20_GR	FAN(FAN3)		
CN22_YL	FAN(INV2)		
CN23_GY	FAN(INV1)		
CN21_WH	HIGH PRESSURE SENSOR 1		
CN22_BK	LOW PRESSURE SENSOR 1		
CN23_BL	LOW PRESSURE SENSOR 2		
CN24_RD	LOW PRESSURE SENSOR 2		
CN25_BL	LIQUID PIPE THERMISTOR(INLET, OUTLET)		
CN26_GR	THERMISTOR(SUCTON1, LIQUID1, DISCHARGE1)		
CN27_YL	THERMISTOR(SUCTON2, LIQUID2, DISCHARGE2)		
CN28_VI	THERMISTOR(HEX1)		
CN29_BK	THERMISTOR(HEX2)		
CN40_RD	MAIN ELECTRONIC EXPANSION VALVE 1		
CN41_WH	MAIN ELECTRONIC EXPANSION VALVE 2		
CN42_WH	MAIN PCB COMMUNICATION TERMINAL		
CN48_TB	TERMINAL BLOCK		
CN_F_G	EARTH WIRE		

MEZ67329409 (REV02)

## 1 Unit, 2 Unit(Main), 3 Unit(Main)

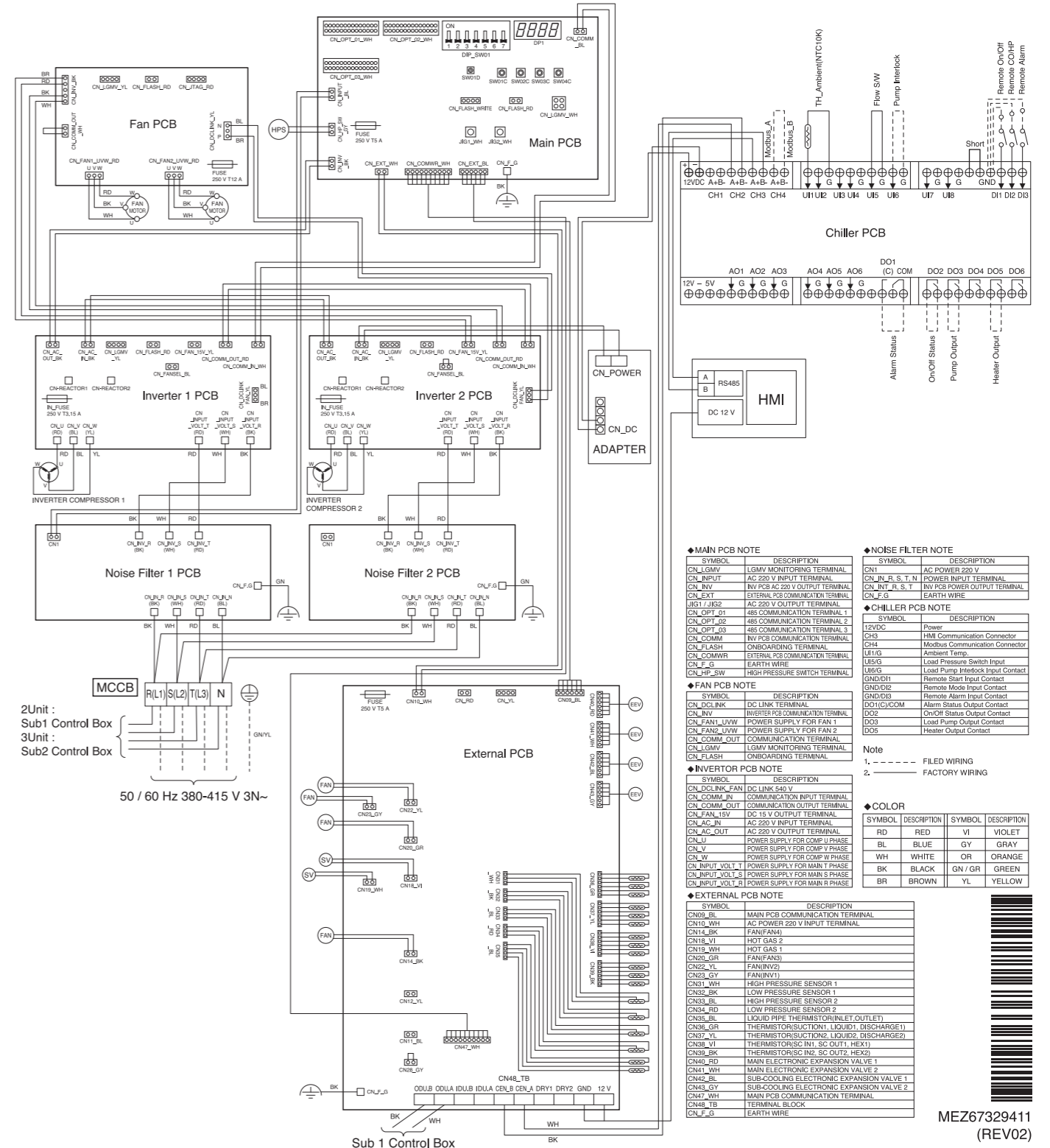

SYMBOL	DESCRIPTION	SYMBOL	DESCRIPTION
CN_LGMV	LGMV MONITORING TERMINAL	CN1	AC POWER 220 V
CN_INV	AC 220 V INPUT TERMINAL	CN_IN_R, S, T, N	AC POWER INPUT TERMINAL
CN_INVV	INV PCB AC 220 V OUTPUT TERMINAL	CN_INT_R, S, T, N	INV PCB POWER OUTPUT TERMINAL
CN_EXT	EXTERNAL PCB COMMUNICATION TERMINAL	CN_F_G	EARTH WIRE
JIG1 / JIG2	AC 220 V OUTPUT TERMINAL		
CN_OPT_01	485 COMMUNICATION TERMINAL 1		
CN_OPT_02	485 COMMUNICATION TERMINAL 2		
CN_OPT_03	485 COMMUNICATION TERMINAL 3		
CN_COMM	INV PCB COMMUNICATION TERMINAL		
CN_FLASH	ONBOARDING TERMINAL		
CN_COMMR	EXTERNAL PCB COMMUNICATION TERMINAL		
CN_F_G	EARTH WIRE		
CN_HP_SW	HIGH PRESSURE SWITCH TERMINAL		

SYMBOL	DESCRIPTION	SYMBOL	DESCRIPTION
CN_DCLINK	DC LINK TERMINAL	RD	RED VI VIOLET
CN_INV	INVERTER PCB COMMUNICATION TERMINAL	BL	BLUE GY GRAY
CN_FAN1_UVW	POWER SUPPLY FOR FAN 1	WH	WHITE OR ORANGE
CN_FAN2_UVW	POWER SUPPLY FOR FAN 2	BK	BLACK GN / GR GREEN
CN_COMM_OUT	COMMUNICATION TERMINAL	BR	BROWN YL YELLOW
CN_FLASH	ONBOARDING TERMINAL		

  

SYMBOL	DESCRIPTION	SYMBOL	DESCRIPTION
CN_DCLINK_FAN	DC LINK 540 V		
CN_COMM_IN	COMMUNICATION INPUT TERMINAL		
CN_COMM_OUT	COMMUNICATION OUTPUT TERMINAL		
CN_FAN_15V	DC 15 V OUTPUT TERMINAL		
CN_AC_IN	AC 220 V INPUT TERMINAL		
CN_AC_OUT	AC 220 V OUTPUT TERMINAL		
CN_U	POWER SUPPLY FOR COMP U PHASE		
CN_V	POWER SUPPLY FOR COMP V PHASE		
CN_W	POWER SUPPLY FOR COMP W PHASE		
CN_INPUT_VOLT_S	POWER SUPPLY FOR MAIN S PHASE		
CN_INPUT_VOLT_R	POWER SUPPLY FOR MAIN R PHASE		

SYMBOL	DESCRIPTION	SYMBOL	DESCRIPTION
CN09_BL	MAIN PCB COMMUNICATION TERMINAL		
CN10_WH	AC POWER 220 V INPUT TERMINAL		
CN14_BK	FAN(FAN4)		
CN18_VI	HOT GAS 2		
CN19_WH	HOT GAS 1		
CN20_GR	FAN(FAN3)		
CN22_YL	FAN(INV2)		
CN23_GY	FAN(INV1)		
CN21_WH	HIGH PRESSURE SENSOR 1		
CN22_BK	LOW PRESSURE SENSOR 1		
CN23_BL	LOW PRESSURE SENSOR 2		
CN24_RD	LOW PRESSURE SENSOR 2		
CN25_BL	LIQUID PIPE THERMISTOR(INLET, OUTLET)		
CN26_GR	THERMISTOR(SUCTON1, LIQUID1, DISCHARGE1)		
CN27_YL	THERMISTOR(SUCTON2, LIQUID2, DISCHARGE2)		
CN28_VI	THERMISTOR(HEX1)		
CN29_BK	THERMISTOR(HEX2)		
CN40_RD	MAIN ELECTRONIC EXPANSION VALVE 1		
CN41_WH	MAIN ELECTRONIC EXPANSION VALVE 2		
CN42_WH	MAIN PCB COMMUNICATION TERMINAL		
CN48_TB	TERMINAL BLOCK		
CN_F_G	EARTH WIRE		

### 2 Unit(Sub), 3 Unit(Sub2)

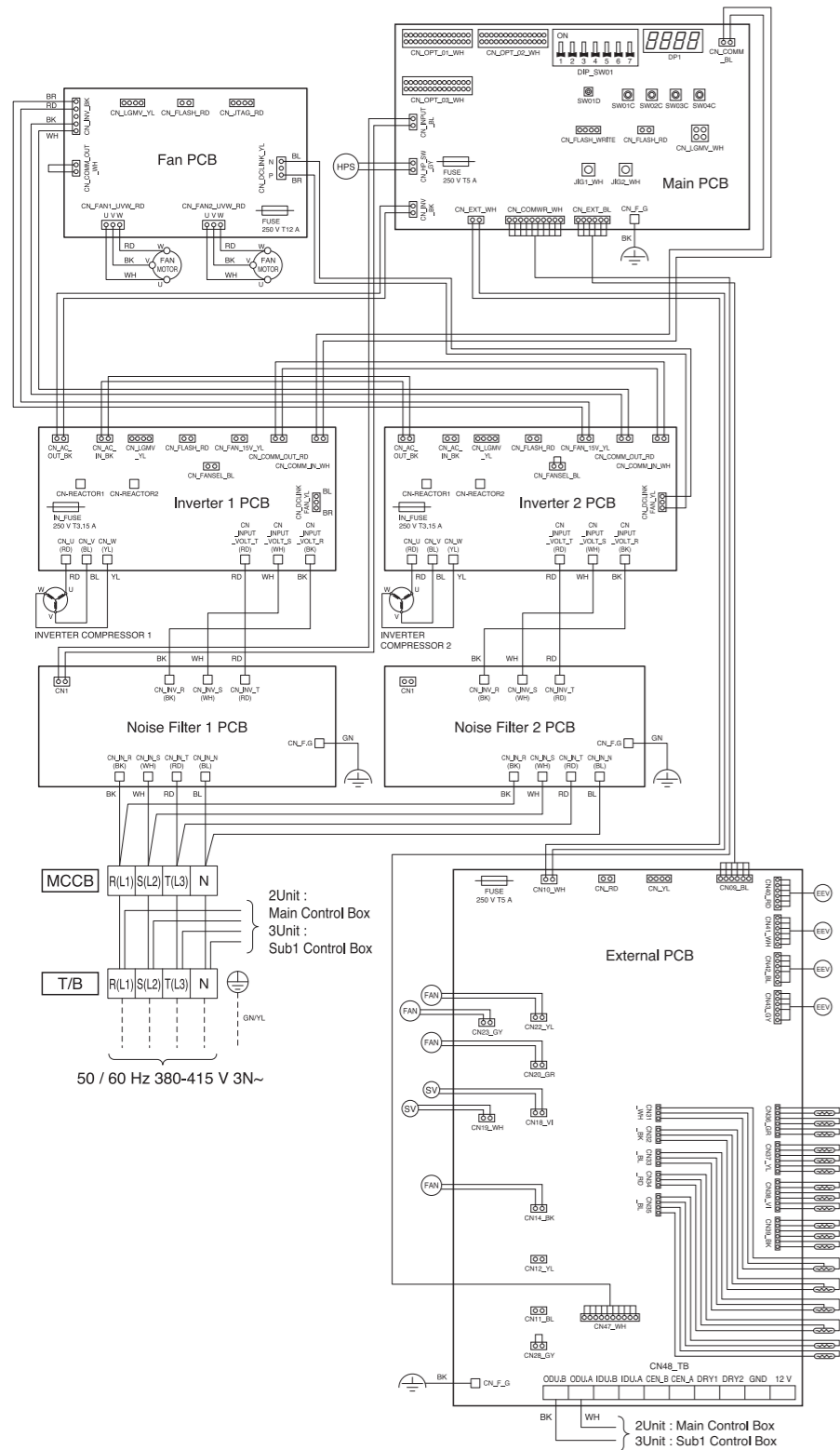

**◆MAIN PCB NOTE**

SYMBOL	DESCRIPTION
CN_LGMV	LGMV MONITORING TERMINAL
CN_INP	AC 220 V INPUT TERMINAL
CN_EXT	EXTERNAL PCB COMMUNICATION TERMINAL
CN_OPT_01	48S COMMUNICATION TERMINAL 1
CN_OPT_02	48S COMMUNICATION TERMINAL 2
CN_OPT_03	48S COMMUNICATION TERMINAL 3
CN_COMM	RV PCB COMMUNICATION TERMINAL
CN_FLASH	ONBOARDING TERMINAL
CN_COMMWR	EXTERNAL PCB COMMUNICATION TERMINAL
CN_F_G	EARTH WIRE
CN_HP_SW	HIGH PRESSURE SWITCH TERMINAL

**◆NOISE FILTER NOTE**

SYMBOL	DESCRIPTION
CN1	AC POWER 220 V
CN_IN_R, S, T, N	POWER INPUT TERMINAL
CN_INT_R, S, T, N	RV PCB POWER OUTPUT TERMINAL
CN_F_G	EARTH WIRE

Note  
1. - - - - - FILED WIRING  
2. - - - - - FACTORY WIRING

**◆FAN PCB NOTE**

SYMBOL	DESCRIPTION
CN_DCLINK	DC LINK TERMINAL
CN_INV	INVERTER PCB COMMUNICATION TERMINAL
CN_FAN1_UVW	POWER SUPPLY FOR FAN 1
CN_FAN2_UVW	POWER SUPPLY FOR FAN 2
CN_COMM_OUT	COMMUNICATION TERMINAL
CN_LGMV	LGMV MONITORING TERMINAL
CN_FLASH	ONBOARDING TERMINAL

**◆INVERTER PCB NOTE**

SYMBOL	DESCRIPTION
CN_DCLINK_FAN	DC LINK 540 V
CN_COMM_IN	COMMUNICATION INPUT TERMINAL
CN_COMM_OUT	COMMUNICATION OUTPUT TERMINAL
CN_FAN_TSV	DC 15 V OUTPUT TERMINAL
CN_AC_IN	AC 220 V INPUT TERMINAL
CN_AC_OUT	AC 220 V OUTPUT TERMINAL
CN_U	POWER SUPPLY FOR COMP U PHASE
CN_V	POWER SUPPLY FOR COMP V PHASE
CN_W	POWER SUPPLY FOR COMP W PHASE
CN_INP_VOLT_T	POWER SUPPLY FOR MAIN T PHASE
CN_INP_VOLT_S	POWER SUPPLY FOR MAIN S PHASE
CN_INP_VOLT_R	POWER SUPPLY FOR MAIN R PHASE

**◆EXTERNAL PCB NOTE**

SYMBOL	DESCRIPTION
CN20_RL	MAIN PCB COMMUNICATION TERMINAL
CN10_WH	AC POWER 220 V INPUT TERMINAL
CN14_BK	FAN(FAN4)
CN16_VI	HOT GAS 2
CN18_WH	HOT GAS 1
CN20_GR	FAN(FAN3)
CN22_YL	FAN(FAN2)
CN24_GY	FAN(FAN1)
CN31_WH	HIGH PRESSURE SENSOR 1
CN32_BK	LOW PRESSURE SENSOR 1
CN33_BK	HIGH PRESSURE SENSOR 2
CN34_RD	LOW PRESSURE SENSOR 2
CN35_BK	LIQUID PIPE THERMISTOR(INLET OUTLET)
CN36_BK	THERMISTOR(SUCTON1; LIQUID; DISCHARGE1)
CN37_YL	THERMISTOR(SUCTON2; LIQUID; DISCHARGE2)
CN38_VI	THERMISTOR(SC IN; SC OUT1; HEX1)
CN39_BK	THERMISTOR(SC IN; SC OUT2; HEX2)
CN40_RD	MAIN ELECTRONIC EXPANSION VALVE 1
CN41_WH	MAIN ELECTRONIC EXPANSION VALVE 2
CN42_BK	SUB-COOLING ELECTRONIC EXPANSION VALVE 1
CN43_GY	SUB-COOLING ELECTRONIC EXPANSION VALVE 2
CN47_WH	MAIN PCB COMMUNICATION TERMINAL
CN48_TB	TERMINAL BLOCK
CN_F_G	EARTH WIRE

**◆COLOR**

SYMBOL	DESCRIPTION	SYMBOL	DESCRIPTION
RD	RED	VI	VIOLET
BL	BLUE	GY	GRAY
WH	WHITE	OR	ORANGE
BK	BLACK	GN / GR	GREEN
BR	BROWN	YL	YELLOW

MEZ67329412 (REV02)

### 3 Unit(Sub1)

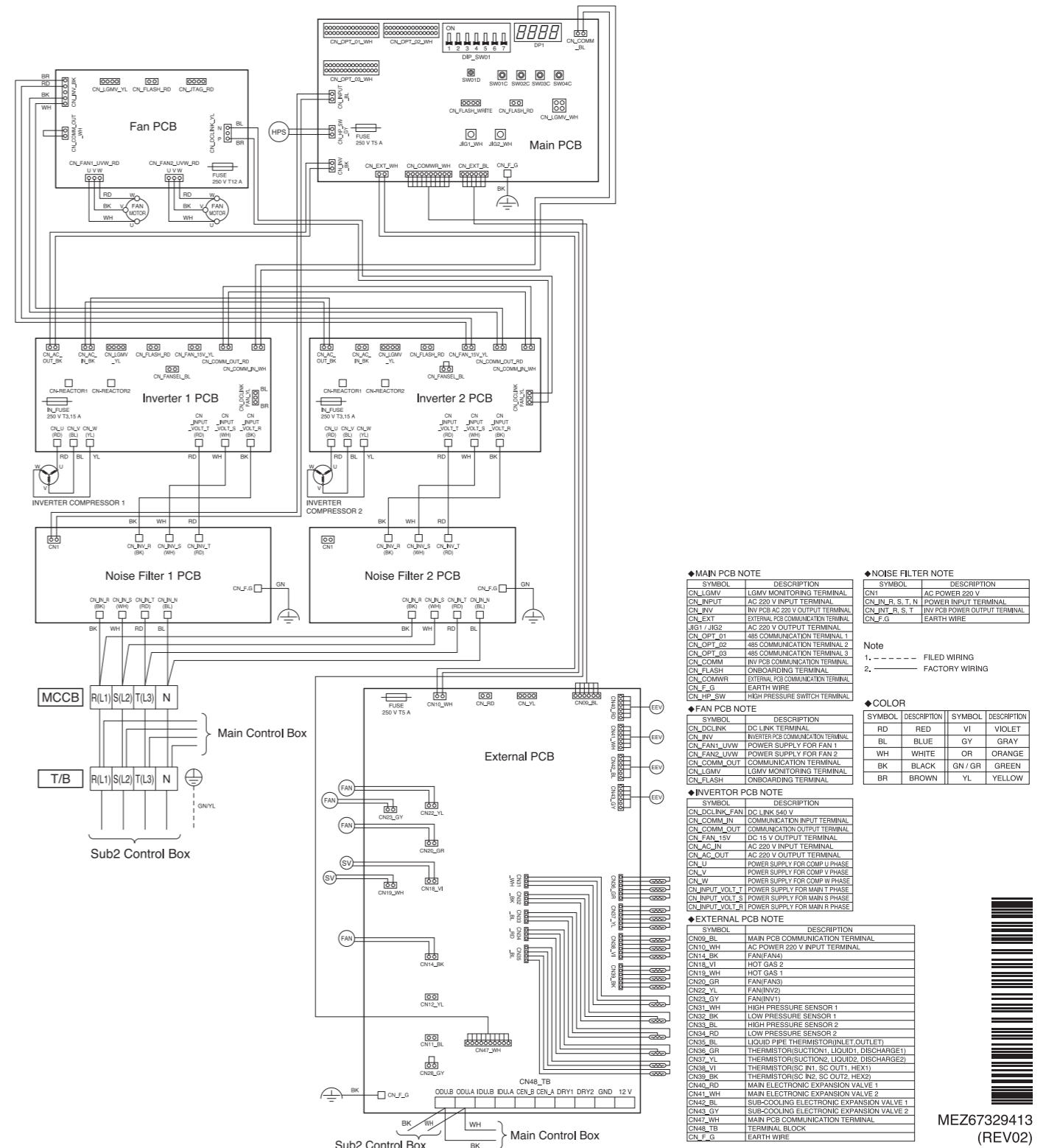

**◆MAIN PCB NOTE**

SYMBOL	DESCRIPTION
CN_LGMV	LGMV MONITORING TERMINAL
CN_INP	AC 220 V INPUT TERMINAL
CN_EXT	EXTERNAL PCB COMMUNICATION TERMINAL
CN_OPT_01	48S COMMUNICATION TERMINAL 1
CN_OPT_02	48S COMMUNICATION TERMINAL 2
CN_OPT_03	48S COMMUNICATION TERMINAL 3
CN_COMM	RV PCB COMMUNICATION TERMINAL
CN_FLASH	ONBOARDING TERMINAL
CN_COMMWR	EXTERNAL PCB COMMUNICATION TERMINAL
CN_F_G	EARTH WIRE
CN_HP_SW	HIGH PRESSURE SWITCH TERMINAL

**◆NOISE FILTER NOTE**

SYMBOL	DESCRIPTION
CN1	AC POWER 220 V
CN_IN_R, S, T, N	POWER INPUT TERMINAL
CN_INT_R, S, T, N	RV PCB POWER OUTPUT TERMINAL
CN_F_G	EARTH WIRE

Note  
1. - - - - - FILED WIRING  
2. - - - - - FACTORY WIRING

**◆FAN PCB NOTE**

SYMBOL	DESCRIPTION
CN_DCLINK	DC LINK TERMINAL
CN_INV	INVERTER PCB COMMUNICATION TERMINAL
CN_FAN1_UVW	POWER SUPPLY FOR FAN 1
CN_FAN2_UVW	POWER SUPPLY FOR FAN 2
CN_COMM_OUT	COMMUNICATION TERMINAL
CN_LGMV	LGMV MONITORING TERMINAL
CN_FLASH	ONBOARDING TERMINAL

**◆INVERTER PCB NOTE**

SYMBOL	DESCRIPTION
CN_DCLINK_FAN	DC LINK 540 V
CN_COMM_IN	COMMUNICATION INPUT TERMINAL
CN_COMM_OUT	COMMUNICATION OUTPUT TERMINAL
CN_FAN_TSV	DC 15 V OUTPUT TERMINAL
CN_AC_IN	AC 220 V INPUT TERMINAL
CN_AC_OUT	AC 220 V OUTPUT TERMINAL
CN_U	POWER SUPPLY FOR COMP U PHASE
CN_V	POWER SUPPLY FOR COMP V PHASE
CN_W	POWER SUPPLY FOR COMP W PHASE
CN_INP_VOLT_T	POWER SUPPLY FOR MAIN T PHASE
CN_INP_VOLT_S	POWER SUPPLY FOR MAIN S PHASE
CN_INP_VOLT_R	POWER SUPPLY FOR MAIN R PHASE

**◆EXTERNAL PCB NOTE**

SYMBOL	DESCRIPTION
CN20_RL	MAIN PCB COMMUNICATION TERMINAL
CN10_WH	AC POWER 220 V INPUT TERMINAL
CN14_BK	FAN(FAN4)
CN16_VI	HOT GAS 2
CN18_WH	HOT GAS 1
CN20_GR	FAN(FAN3)
CN22_YL	FAN(FAN2)
CN24_GY	FAN(FAN1)
CN31_WH	HIGH PRESSURE SENSOR 1
CN32_BK	LOW PRESSURE SENSOR 1
CN33_BK	HIGH PRESSURE SENSOR 2
CN34_RD	LOW PRESSURE SENSOR 2
CN35_BK	LIQUID PIPE THERMISTOR(INLET OUTLET)
CN36_BK	THERMISTOR(SUCTON1; LIQUID; DISCHARGE1)
CN37_YL	THERMISTOR(SUCTON2; LIQUID; DISCHARGE2)
CN38_VI	THERMISTOR(SC IN; SC OUT1; HEX1)
CN39_BK	THERMISTOR(SC IN; SC OUT2; HEX2)
CN40_RD	MAIN ELECTRONIC EXPANSION VALVE 1
CN41_WH	MAIN ELECTRONIC EXPANSION VALVE 2
CN42_BK	SUB-COOLING ELECTRONIC EXPANSION VALVE 1
CN43_GY	SUB-COOLING ELECTRONIC EXPANSION VALVE 2
CN47_WH	MAIN PCB COMMUNICATION TERMINAL
CN48_TB	TERMINAL BLOCK
CN_F_G	EARTH WIRE

**◆COLOR**

SYMBOL	DESCRIPTION	SYMBOL	DESCRIPTION
RD	RED	VI	VIOLET
BL	BLUE	GY	GRAY
WH	WHITE	OR	ORANGE
BK	BLACK	GN / GR	GREEN
BR	BROWN	YL	YELLOW

MEZ67329413 (REV02)

### 1 Unit, 2 Unit(Main), 3 Unit(Main)

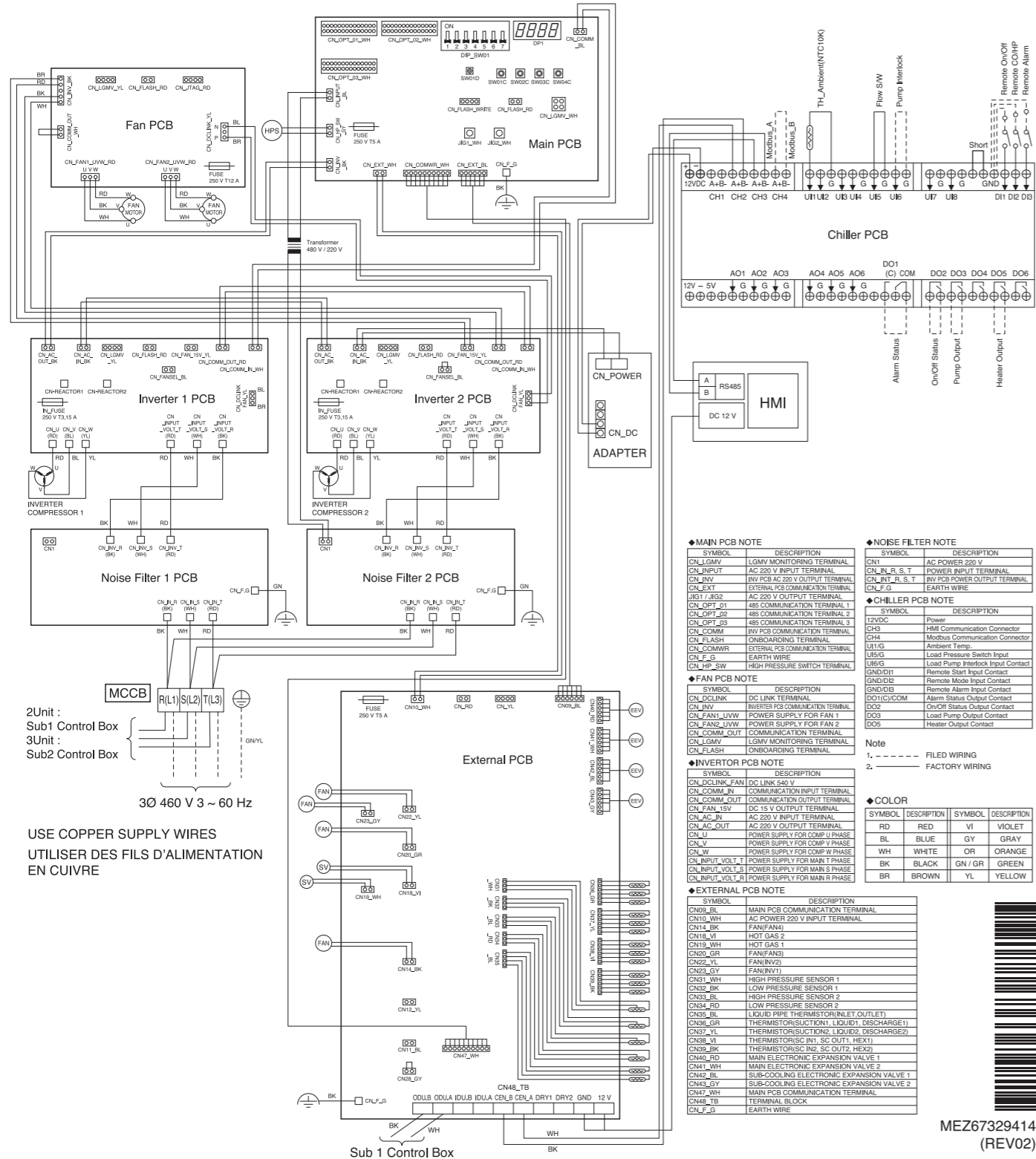

**◆MAIN PCB NOTE**

SYMBOL	DESCRIPTION
CN_LGMV	LGMV MONITORING TERMINAL
CN_INPUT	AC 220 V INPUT TERMINAL
CN_INV	INV PCB AC 220 V OUTPUT TERMINAL
CN_EXT	EXTERNAL PCB COMMUNICATION TERMINAL
JIG1/JIG2	AC 220 V OUTPUT TERMINAL
CN_OPT_01	485 COMMUNICATION TERMINAL 1
CN_OPT_02	485 COMMUNICATION TERMINAL 2
CN_OPT_03	485 COMMUNICATION TERMINAL 3
CN_COMM	INV PCB COMMUNICATION TERMINAL
CN_FLASH	ONBOARDING TERMINAL
CN_COMMWR	EXTERNAL PCB COMMUNICATION TERMINAL
CN_F_G	EARTH WIRE
CN_HP_SW	HIGH PRESSURE SWITCH TERMINAL

**◆FAN PCB NOTE**

SYMBOL	DESCRIPTION
CN_DCLINK	DC LINK TERMINAL
CN_INV	INVERTER PCB COMMUNICATION TERMINAL
CN_FAN1_UVW	POWER SUPPLY FOR FAN 1
CN_FAN2_UVW	POWER SUPPLY FOR FAN 2
CN_COMM_OUT	COMMUNICATION TERMINAL
CN_FLASH	ONBOARDING TERMINAL

**◆INVERTOR PCB NOTE**

SYMBOL	DESCRIPTION
CN_DCLINK_FAN	DC LINK 540 V
CN_COMM_IN	COMMUNICATION INPUT TERMINAL
CN_COMM_OUT	COMMUNICATION OUTPUT TERMINAL
CN_FAN_15V	DC 15 V OUTPUT TERMINAL
CN_AC_IN	AC 220 V INPUT TERMINAL
CN_AC_OUT	AC 220 V OUTPUT TERMINAL
CN_U	POWER SUPPLY FOR COMP U PHASE
CN_V	POWER SUPPLY FOR COMP V PHASE
CN_W	POWER SUPPLY FOR COMP W PHASE
CN_INPUT_VOLT_T	POWER SUPPLY FOR MAIN T PHASE
CN_INPUT_VOLT_S	POWER SUPPLY FOR MAIN S PHASE
CN_INPUT_VOLT_R	POWER SUPPLY FOR MAIN R PHASE

**◆EXTERNAL PCB NOTE**

SYMBOL	DESCRIPTION
CN09_BK	MAIN PCB COMMUNICATION TERMINAL
CN10_WH	AC POWER 220 V INPUT TERMINAL
CN11_BK	FAN(FAN4)
CN18_VI	HOT GAS 2
CN19_WH	HOT GAS 1
CN20_GR	FAN(FAN3)
CN22_YL	FAN(INV2)
CN23_GY	FAN(INV1)
CN32_BK	HIGH PRESSURE SENSOR 1
CN33_BK	LOW PRESSURE SENSOR 1
CN34_RD	HIGH PRESSURE SENSOR 2
CN35_RD	LOW PRESSURE SENSOR 2
CN36_BK	LIQUID PIPE THERMISTOR(INLET, OUTLET)
CN37_GY	THERMISTOR(SUCTON1, LIQUID, DISCHARGE1)
CN38_VI	THERMISTOR(SUCTON2, LIQUID, DISCHARGE2)
CN39_VI	THERMISTOR(SC IN1, SC OUT1, HEX1)
CN39_BK	THERMISTOR(SC IN2, SC OUT2, HEX2)
CN39_RD	MAIN ELECTRONIC EXPANSION VALVE 1
CN41_WH	MAIN ELECTRONIC EXPANSION VALVE 2
CN42_BK	SUB-COOLING ELECTRONIC EXPANSION VALVE 1
CN43_GY	SUB-COOLING ELECTRONIC EXPANSION VALVE 2
CN44_WH	MAIN PCB COMMUNICATION TERMINAL
CN48_TB	TERMINAL BLOCK
CN_F_G	EARTH WIRE

**◆NOISE FILTER NOTE**

SYMBOL	DESCRIPTION
CN1	AC POWER 220 V
CN_IN_V	INV PCB AC 220 V OUTPUT TERMINAL
CN_F_G	EARTH WIRE

**◆CHILLER PCB NOTE**

SYMBOL	DESCRIPTION
12VDC	Power
CH4	HMI Communication Connector
MODBUS	Modbus Communication Connector
U1/U2	Ambient Temp.
U1/SG	Load Pressure Switch Input
U1/SG	Load Pump Interlock Input Contact
GN(DI1)	Remote Start Input Contact
GN(DI2)	Remote Alarm Input Contact
DO1(C)/COM	Alarm Status Output Contact
DO2	On/Off Status Output Contact
DO3	Load Pump Output Contact
DO5	Heater Output Contact

**Note**  
 1. - - - - - FILED WIRING  
 2. ———— FACTORY WIRING

**◆COLOR**

SYMBOL	DESCRIPTION	SYMBOL	DESCRIPTION
RD	RED	VI	VIOLET
BL	BLUE	GY	GRAY
WH	WHITE	OR	ORANGE
BK	BLACK	GN / GR	GREEN
BR	BROWN	YL	YELLOW

### 2 Unit(Sub), 3 Unit(Sub2)

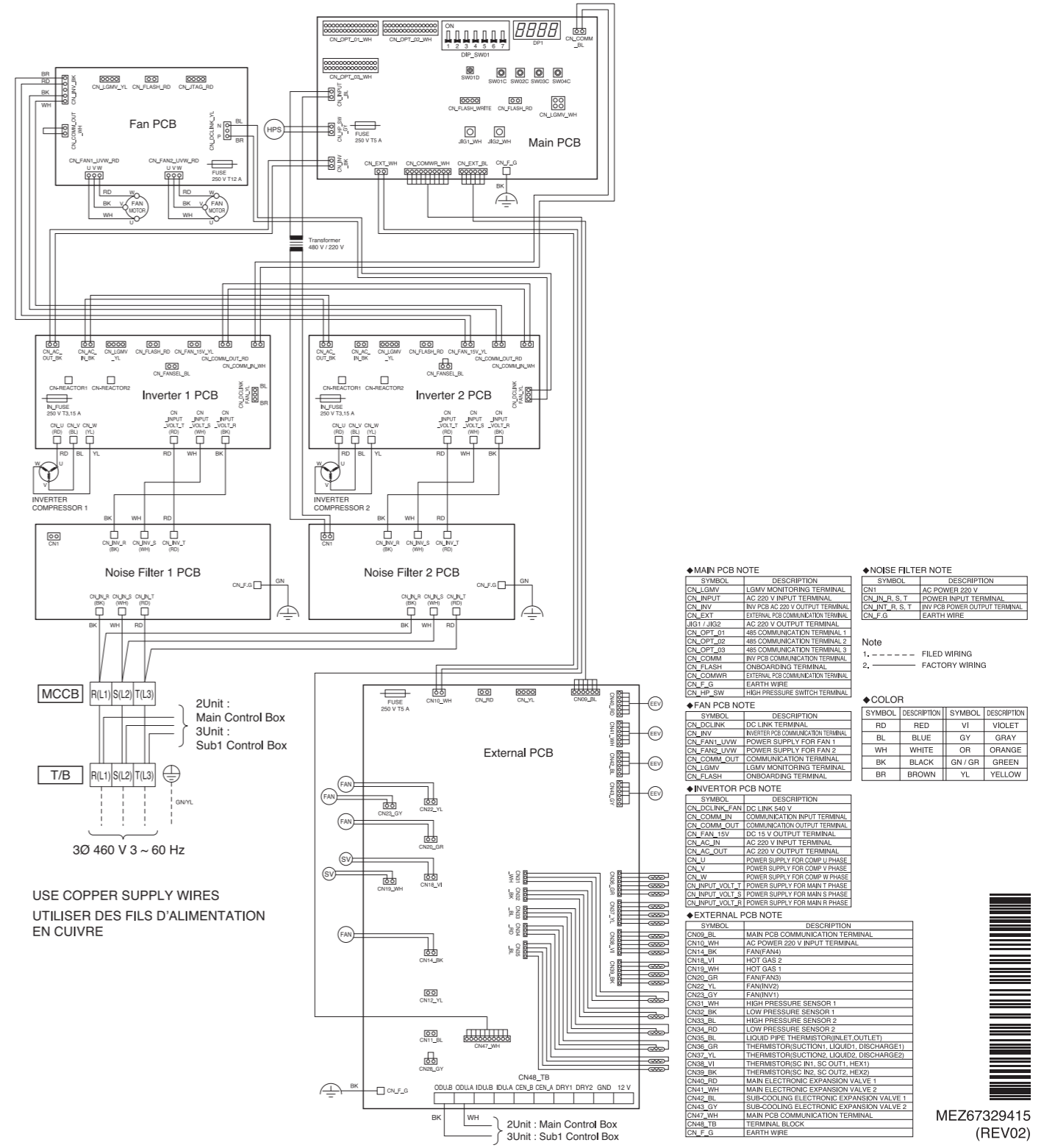

**◆MAIN PCB NOTE**

SYMBOL	DESCRIPTION
CN_LGMV	LGMV MONITORING TERMINAL
CN_INPUT	AC 220 V INPUT TERMINAL
CN_INV	INV PCB AC 220 V OUTPUT TERMINAL
CN_EXT	EXTERNAL PCB COMMUNICATION TERMINAL
JIG1/JIG2	AC 220 V OUTPUT TERMINAL
CN_OPT_01	485 COMMUNICATION TERMINAL 1
CN_OPT_02	485 COMMUNICATION TERMINAL 2
CN_OPT_03	485 COMMUNICATION TERMINAL 3
CN_COMM	INV PCB COMMUNICATION TERMINAL
CN_FLASH	ONBOARDING TERMINAL
CN_COMMWR	EXTERNAL PCB COMMUNICATION TERMINAL
CN_F_G	EARTH WIRE
CN_HP_SW	HIGH PRESSURE SWITCH TERMINAL

**◆FAN PCB NOTE**

SYMBOL	DESCRIPTION
CN_DCLINK	DC LINK TERMINAL
CN_INV	INVERTER PCB COMMUNICATION TERMINAL
CN_FAN1_UVW	POWER SUPPLY FOR FAN 1
CN_FAN2_UVW	POWER SUPPLY FOR FAN 2
CN_COMM_OUT	COMMUNICATION TERMINAL
CN_FLASH	LGMV MONITORING TERMINAL
CN_LGMV	ONBOARDING TERMINAL

**◆INVERTOR PCB NOTE**

SYMBOL	DESCRIPTION
CN_DCLINK_FAN	DC LINK 540 V
CN_COMM_IN	COMMUNICATION INPUT TERMINAL
CN_COMM_OUT	COMMUNICATION OUTPUT TERMINAL
CN_FAN_15V	DC 15 V OUTPUT TERMINAL
CN_AC_IN	AC 220 V INPUT TERMINAL
CN_AC_OUT	AC 220 V OUTPUT TERMINAL
CN_U	POWER SUPPLY FOR COMP U PHASE
CN_V	POWER SUPPLY FOR COMP V PHASE
CN_W	POWER SUPPLY FOR COMP W PHASE
CN_INPUT_VOLT_T	POWER SUPPLY FOR MAIN T PHASE
CN_INPUT_VOLT_S	POWER SUPPLY FOR MAIN S PHASE
CN_INPUT_VOLT_R	POWER SUPPLY FOR MAIN R PHASE

**◆EXTERNAL PCB NOTE**

SYMBOL	DESCRIPTION
CN09_BK	MAIN PCB COMMUNICATION TERMINAL
CN10_WH	AC POWER 220 V INPUT TERMINAL
CN11_BK	FAN(FAN4)
CN18_VI	HOT GAS 2
CN19_WH	HOT GAS 1
CN20_GR	FAN(FAN3)
CN22_YL	FAN(INV2)
CN23_GY	FAN(INV1)
CN32_BK	HIGH PRESSURE SENSOR 1
CN33_BK	LOW PRESSURE SENSOR 1
CN34_RD	HIGH PRESSURE SENSOR 2
CN35_RD	LOW PRESSURE SENSOR 2
CN36_BK	LIQUID PIPE THERMISTOR(INLET, OUTLET)
CN37_GY	THERMISTOR(SUCTON1, LIQUID, DISCHARGE1)
CN38_VI	THERMISTOR(SUCTON2, LIQUID, DISCHARGE2)
CN39_VI	THERMISTOR(SC IN1, SC OUT1, HEX1)
CN39_BK	THERMISTOR(SC IN2, SC OUT2, HEX2)
CN39_RD	MAIN ELECTRONIC EXPANSION VALVE 1
CN41_WH	MAIN ELECTRONIC EXPANSION VALVE 2
CN42_BK	SUB-COOLING ELECTRONIC EXPANSION VALVE 1
CN43_GY	SUB-COOLING ELECTRONIC EXPANSION VALVE 2
CN44_WH	MAIN PCB COMMUNICATION TERMINAL
CN48_TB	TERMINAL BLOCK
CN_F_G	EARTH WIRE

**Note**  
 1. - - - - - FILED WIRING  
 2. ———— FACTORY WIRING

**◆COLOR**

SYMBOL	DESCRIPTION	SYMBOL	DESCRIPTION
RD	RED	VI	VIOLET
BL	BLUE	GY	GRAY
WH	WHITE	OR	ORANGE
BK	BLACK	GN / GR	GREEN
BR	BROWN	YL	YELLOW



### 3 Unit(Sub1)

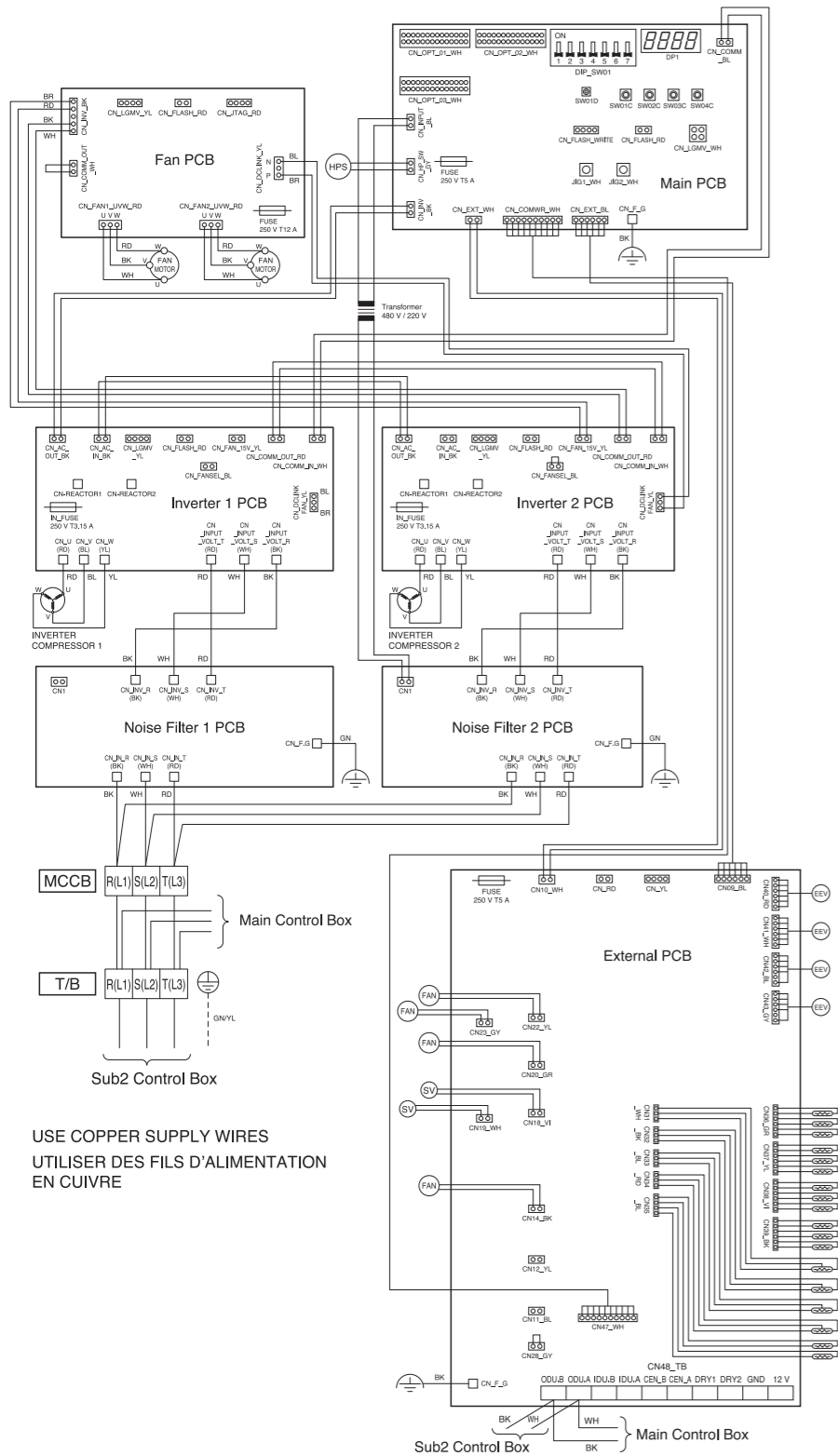

#### ◆MAIN PCB NOTE

SYMBOL	DESCRIPTION
CN_LGMV	LGMV MONITORING TERMINAL
CN_INPVT	AC 220 V INPUT TERMINAL
CN_INV	INV PCB AC 220 V OUTPUT TERMINAL
CN_EXT	EXTERNAL PCB COMMUNICATION TERMINAL
JG1 / JG2	AC 220 V OUTPUT TERMINAL
CN_OPT_01	485 COMMUNICATION TERMINAL 1
CN_OPT_02	485 COMMUNICATION TERMINAL 2
CN_OPT_03	485 COMMUNICATION TERMINAL 3
CN_COMM	INV PCB COMMUNICATION TERMINAL
CN_FLASH	ONBOARDING TERMINAL
CN_COMMWR	EXTERNAL PCB COMMUNICATION TERMINAL
CN_F_G	EARTH WIRE
CN_HP_SW	HIGH PRESSURE SWITCH TERMINAL

#### ◆FAN PCB NOTE

SYMBOL	DESCRIPTION
CN_DLINK	DC LINK TERMINAL
CN_FAN1_LVWV	POWER SUPPLY FOR FAN 1
CN_FAN2_LVWV	POWER SUPPLY FOR FAN 2
CN_COMM_OUT	COMMUNICATION TERMINAL
CN_LGMV	LGMV MONITORING TERMINAL
CN_FLASH	ONBOARDING TERMINAL

#### ◆INVERTOR PCB NOTE

SYMBOL	DESCRIPTION
CN_DLINK_FAN	DC LINK 540 V
CN_COMM_IN	COMMUNICATION INPUT TERMINAL
CN_COMM_OUT	COMMUNICATION OUTPUT TERMINAL
CN_FAN1_SV	DC 15V OUTPUT TERMINAL
CN_AC_IN	AC 220 V INPUT TERMINAL
CN_AC_OUT	AC 220 V OUTPUT TERMINAL
CN_U	POWER SUPPLY FOR COMP U PHASE
CN_V	POWER SUPPLY FOR COMP V PHASE
CN_W	POWER SUPPLY FOR COMP W PHASE
CN_INPVT_VOLT_U	POWER SUPPLY FOR MAIN U PHASE
CN_INPVT_VOLT_S	POWER SUPPLY FOR MAIN S PHASE
CN_INPVT_VOLT_R	POWER SUPPLY FOR MAIN R PHASE

#### ◆EXTERNAL PCB NOTE

SYMBOL	DESCRIPTION
CN20_BR	MAIN PCB COMMUNICATION TERMINAL
CN10_WH	AC POWER 220 V INPUT TERMINAL
CN14_BK	FAN(FAN4)
CN16_VI	HOT GAS 2
CN18_WH	HOT GAS 1
CN20_GR	FAN(FAN3)
CN22_YL	FAN(FAN2)
CN23_GY	FAN(FAN1)
CN31_WH	HIGH PRESSURE SENSOR 1
CN32_BK	LOW PRESSURE SENSOR 1
CN33_BR	HIGH PRESSURE SENSOR 2
CN34_RD	LOW PRESSURE SENSOR 2
CN35_BR	LIQUID PIPE THERMISTOR(INLET OUTLET)
CN36_BR	THERMISTOR(SUCTION1, LIQUID, DISCHARGE1)
CN37_YL	THERMISTOR(SUCTION2, LIQUID, DISCHARGE2)
CN38_VI	THERMISTOR(SC IN), SC OUT1, HEX1)
CN39_BK	THERMISTOR(SC IN), SC OUT2, HEX2)
CN40_RD	MAIN ELECTRONIC EXPANSION VALVE 1
CN41_WH	MAIN ELECTRONIC EXPANSION VALVE 2
CN42_BR	SUB-COOLING ELECTRONIC EXPANSION VALVE 1
CN43_GY	SUB-COOLING ELECTRONIC EXPANSION VALVE 2
CN44_CR	VAPOR INJECTION ELECTRONIC EXPANSION VALVE 1
CN45_BR	VAPOR INJECTION ELECTRONIC EXPANSION VALVE 2
CN47_WH	MAIN PCB COMMUNICATION TERMINAL
CN48_TB	TERMINAL BLOCK
CN_F_G	EARTH WIRE

#### ◆NOISE FILTER NOTE

SYMBOL	DESCRIPTION
CN1	AC POWER 220 V
CN_IN_R, S, T	POWER INPUT TERMINAL
CN_OUT_R, S, T	INV PCB POWER OUTPUT TERMINAL
CN_F_G	EARTH WIRE

Note  
1, - - - - - FILED WIRING  
2, - - - - - FACTORY WIRING

#### ◆COLOR

SYMBOL	DESCRIPTION	SYMBOL	DESCRIPTION
RD	RED	VI	VIOLET
BL	BLUE	GY	GRAY
WH	WHITE	OR	ORANGE
BK	BLACK	GN / GR	GREEN
BR	BROWN	YL	YELLOW

MEZ67329416  
(REV02)

### 1 Unit, 2 Unit(Main)

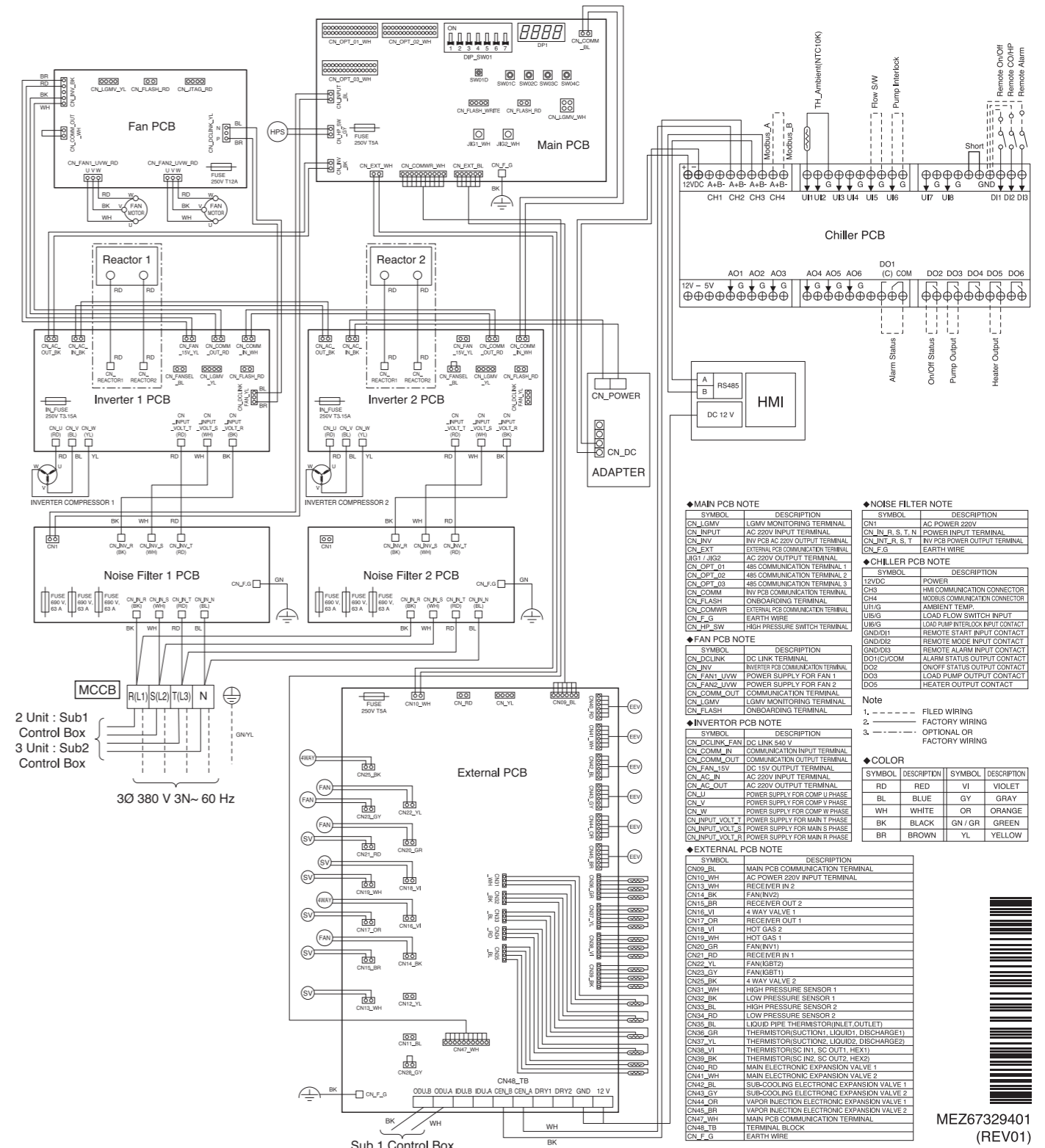

#### ◆MAIN PCB NOTE

SYMBOL	DESCRIPTION
CN_LGMV	LGMV MONITORING TERMINAL
CN_INPVT	AC 220 V INPUT TERMINAL
CN_INV	INV PCB AC 220 V OUTPUT TERMINAL
CN_EXT	EXTERNAL PCB COMMUNICATION TERMINAL
JG1 / JG2	AC 220 V OUTPUT TERMINAL
CN_OPT_01	485 COMMUNICATION TERMINAL 1
CN_OPT_02	485 COMMUNICATION TERMINAL 2
CN_OPT_03	485 COMMUNICATION TERMINAL 3
CN_COMM	INV PCB COMMUNICATION TERMINAL
CN_FLASH	ONBOARDING TERMINAL
CN_COMMWR	EXTERNAL PCB COMMUNICATION TERMINAL
CN_F_G	EARTH WIRE
CN_HP_SW	HIGH PRESSURE SWITCH TERMINAL

#### ◆FAN PCB NOTE

SYMBOL	DESCRIPTION
CN_DLINK	DC LINK TERMINAL
CN_FAN1_LVWV	POWER SUPPLY FOR FAN 1
CN_FAN2_LVWV	POWER SUPPLY FOR FAN 2
CN_COMM_OUT	COMMUNICATION TERMINAL
CN_LGMV	LGMV MONITORING TERMINAL
CN_FLASH	ONBOARDING TERMINAL

#### ◆INVERTOR PCB NOTE

SYMBOL	DESCRIPTION
CN_DLINK_FAN	DC LINK 540 V
CN_COMM_IN	COMMUNICATION INPUT TERMINAL
CN_COMM_OUT	COMMUNICATION OUTPUT TERMINAL
CN_FAN1_SV	DC 15V OUTPUT TERMINAL
CN_AC_IN	AC 220 V INPUT TERMINAL
CN_AC_OUT	AC 220 V OUTPUT TERMINAL
CN_U	POWER SUPPLY FOR COMP U PHASE
CN_V	POWER SUPPLY FOR COMP V PHASE
CN_W	POWER SUPPLY FOR COMP W PHASE
CN_INPVT_VOLT_U	POWER SUPPLY FOR MAIN U PHASE
CN_INPVT_VOLT_S	POWER SUPPLY FOR MAIN S PHASE
CN_INPVT_VOLT_R	POWER SUPPLY FOR MAIN R PHASE

#### ◆EXTERNAL PCB NOTE

SYMBOL	DESCRIPTION
CN09_BR	MAIN PCB COMMUNICATION TERMINAL
CN10_WH	AC POWER 220 V INPUT TERMINAL
CN13_WH	RECEIVER IN 2
CN14_BK	FAN(FAN2)
CN15_BR	RECEIVER OUT 2
CN16_VI	4 WAY VALVE 1
CN17_OR	RECEIVER OUT 1
CN18_WH	HOT GAS 2
CN19_WH	HOT GAS 1
CN20_GR	FAN(FAN1)
CN21_RD	RECEIVER IN 1
CN22_YL	FAN(FAN3)
CN23_GY	FAN(FAN4)
CN25_BK	4 WAY VALVE 2
CN31_WH	HIGH PRESSURE SENSOR 1
CN32_BK	LOW PRESSURE SENSOR 1
CN33_BR	HIGH PRESSURE SENSOR 2
CN34_RD	LOW PRESSURE SENSOR 2
CN35_BR	LIQUID PIPE THERMISTOR(INLET OUTLET)
CN36_BR	THERMISTOR(SUCTION1, LIQUID, DISCHARGE1)
CN37_YL	THERMISTOR(SUCTION2, LIQUID, DISCHARGE2)
CN38_VI	THERMISTOR(SC IN), SC OUT1, HEX1)
CN39_BK	THERMISTOR(SC IN), SC OUT2, HEX2)
CN40_RD	MAIN ELECTRONIC EXPANSION VALVE 1
CN41_WH	MAIN ELECTRONIC EXPANSION VALVE 2
CN42_BR	SUB-COOLING ELECTRONIC EXPANSION VALVE 1
CN43_GY	SUB-COOLING ELECTRONIC EXPANSION VALVE 2
CN44_CR	VAPOR INJECTION ELECTRONIC EXPANSION VALVE 1
CN45_BR	VAPOR INJECTION ELECTRONIC EXPANSION VALVE 2
CN47_WH	MAIN PCB COMMUNICATION TERMINAL
CN48_TB	TERMINAL BLOCK
CN_F_G	EARTH WIRE

#### ◆NOISE FILTER NOTE

SYMBOL	DESCRIPTION
CN1	AC POWER 220V
CN_IN_R, S, T	POWER INPUT TERMINAL
CN_OUT_R, S, T	INV PCB POWER OUTPUT TERMINAL
CN_F_G	EARTH WIRE

#### ◆CHILLER PCB NOTE

SYMBOL	DESCRIPTION
CH1	POWER
CH3	HMI COMMUNICATION CONNECTOR
CH4	MODBUS COMMUNICATION CONNECTOR
UT1G	AMBIENT TEMP
UB1G	LOAD FLOW SWITCH INPUT
UB1S	LOAD PUMP INTERLOCK INPUT CONTACT
UB1D	REMOTE START INPUT CONTACT
UB2D1	REMOTE MODE INPUT CONTACT
UB2D2	REMOTE ALARM INPUT CONTACT
UB2D3	ALARM STATUS OUTPUT CONTACT
DO2	ON/OFF STATUS OUTPUT CONTACT
DO3	LOAD PUMP OUTPUT CONTACT
DO5	HEATER OUTPUT CONTACT

#### Note

1, - - - - - FILED WIRING  
2, - - - - - FACTORY WIRING  
3, - - - - - OPTIONAL OR FACTORY WIRING

#### ◆COLOR

SYMBOL	DESCRIPTION	SYMBOL	DESCRIPTION
RD	RED	VI	VIOLET
BL	BLUE	GY	GRAY
WH	WHITE	OR	ORANGE
BK	BLACK	GN / GR	GREEN
BR	BROWN	YL	YELLOW

MEZ67329401  
(REV01)



### 2 Unit(Sub)

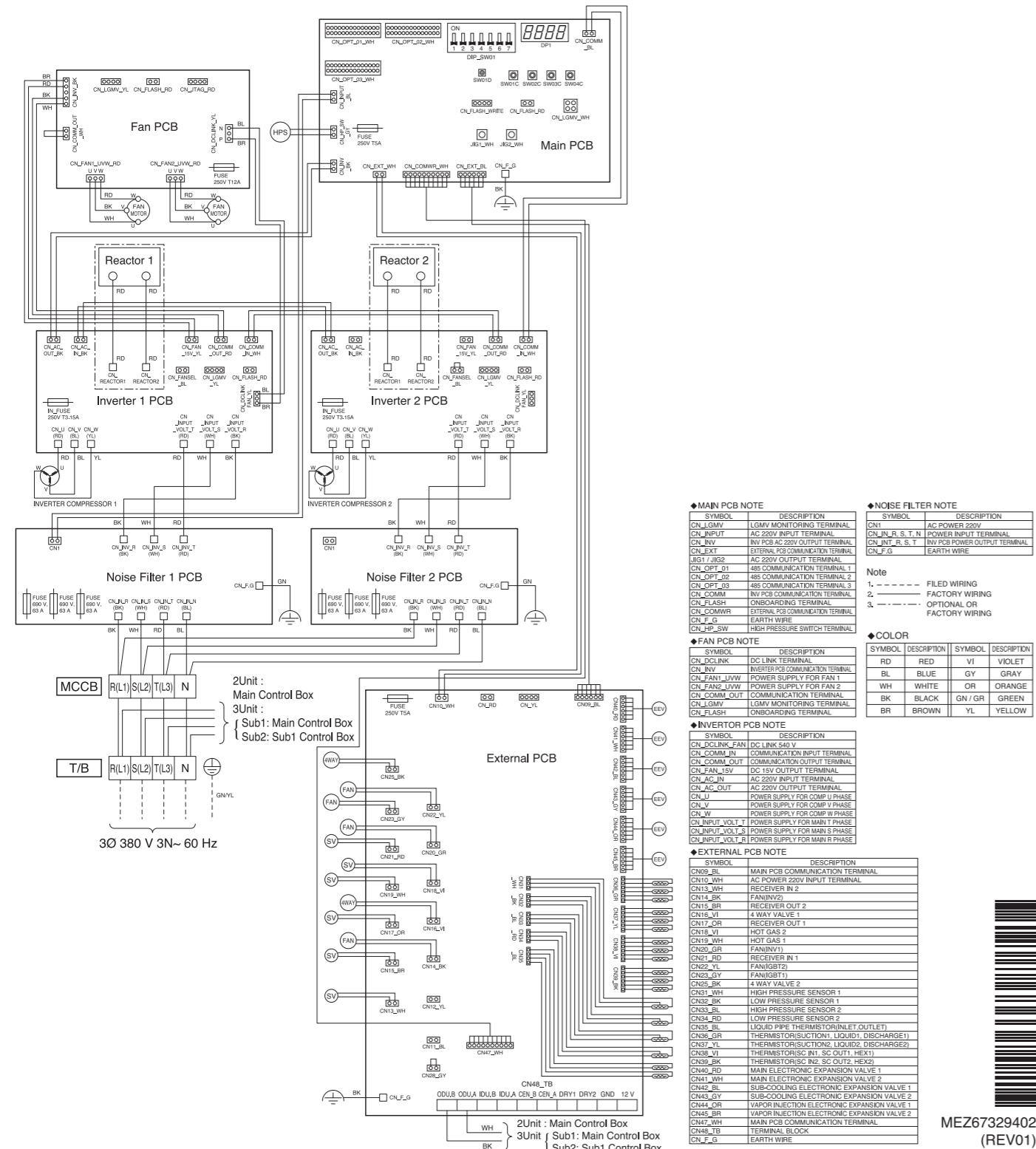

### Consider the service space

There must be sufficient space for maintenance and repair work around the chiller.

Because this is the space where the water pipes are installed, make sure to secure sufficient space for future maintenance and repair work.

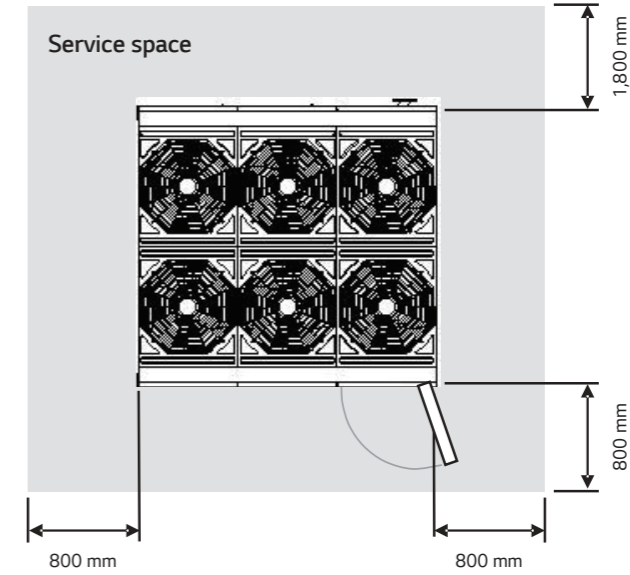

Because this is the space where the water pipes are installed, make sure to secure sufficient space for future maintenance and repair work.

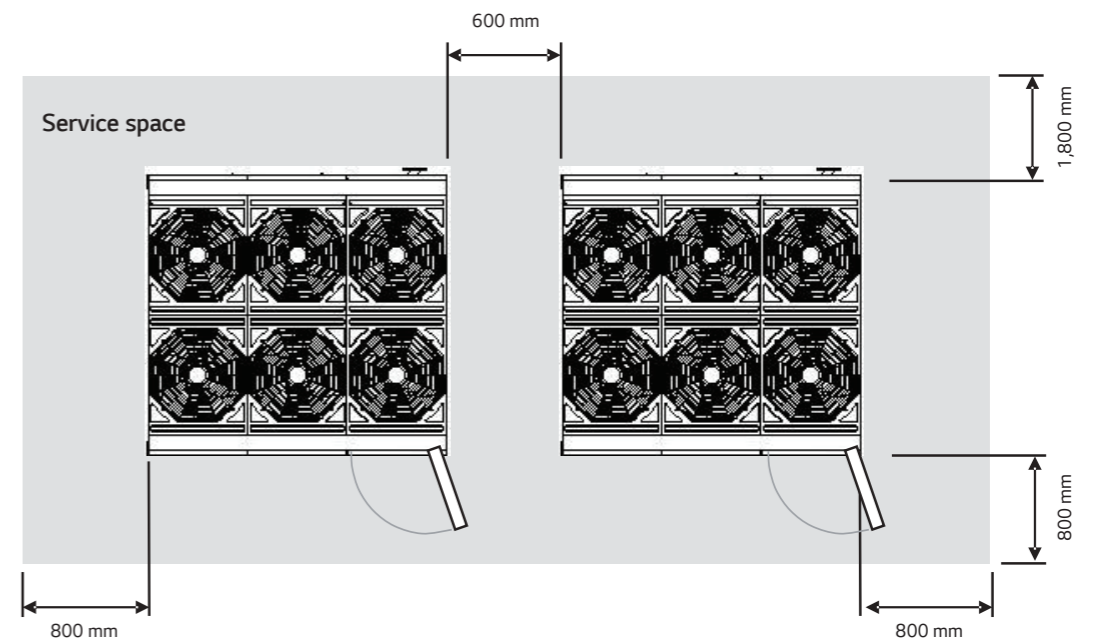

## Water management

The water quality of the cold(Hot) water is described as follows. The water quality must not fall below the following standard. If so, it can be judged to have risk within relatively short period of time.

Item	Water	
	Circulation type cold water	Cold water
PH(25°C)	6.5 - 8.0	6.5 - 8.0
Conduction rate(25°C μs/cm)	500 or below	200 or below
Alkali level(PPM)	100 or below	50 or below
Hardness(PPM)	100 or below	50 or below
Chlorine ion(PPM)	100 or below	50 or below
Lactic acid ion(PPM)	100 or below	50 or below
Iron(PPM)	0.1 or below	0.3 or below
Sulfur ion(PPM)	Not detected	Not detected
Ammonium ion(PPM)	0.5 or below	0.2 or below
Silica(PPM)	50 or below	30 or below

## Water pipe connection

- Connect the pipe so that the entrance of the cold(Hot) water pipe is correct.
- Permitted water pressure resistance of cold water pipe system is 1MPa
- To prevent any external heat loss or dew drops forming during the cooling operation on the water pipe system, apply thermal insulation treatment.
- Install the air vent at the output end of the water pipe.(Air vent)
- If the thermometer is installed on the inlet/outlet of the cold/hot water pipe, the operating condition of the chiller can be checked.
- Always install the strainer(50 Mesh or above) that can be cleaned on the water pipe inlet side to filter any alien particles from entering the heat exchanger.
- Always install the strainer on the leveled pipe.  
(If sand, trash or rust gets mixed to the cold water system, it can cause product failure due to corrosion of metallic parts.)
- Install the on/off valve on the cold water inlet/outlet and bypass pipe on the pipe direction of the device side.
  - For the pipe system, it is recommended to install the bypass and clean the pipe before installing the product and during the annual pipe cleaning.
  - On/Off valve blocks the old water to the chiller that is not operating to reduce the power of the pump.  
Therefore select whether to install to fit the need of the site.
- Install the pressure gauge and thermometer on the inlet and outlet of the water pipe.
- Always install the flexible joint to reduce the vibration of the pipe and product.
  - Vibration of water pipe system is absorbed to prevent water leakage.
- For the cold water system part, make sure to use the component that complies with designed water pressure or above.
- Before supplying cold water to the chiller, clean inside the pipe system to remove any negative impact of particles to the product.

## Detail of the piping around the pump

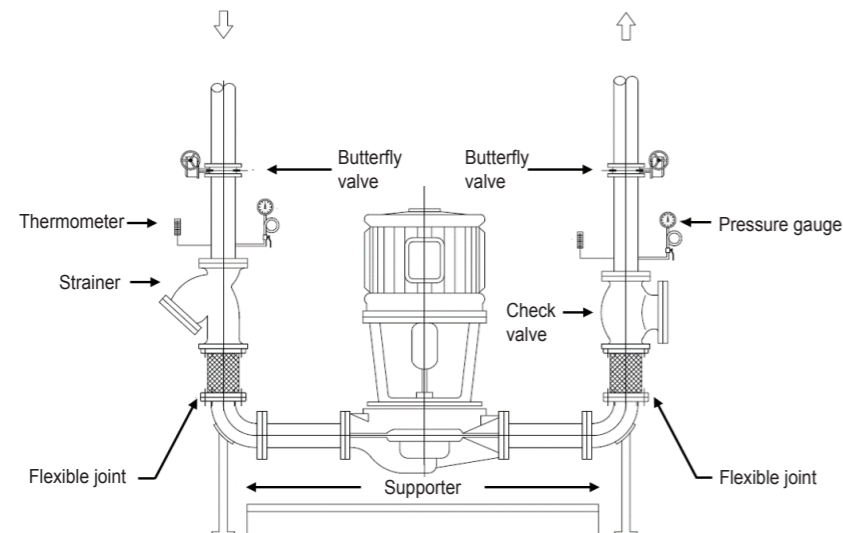

## Installation mode A(Recommended method)

### • Independent product installation

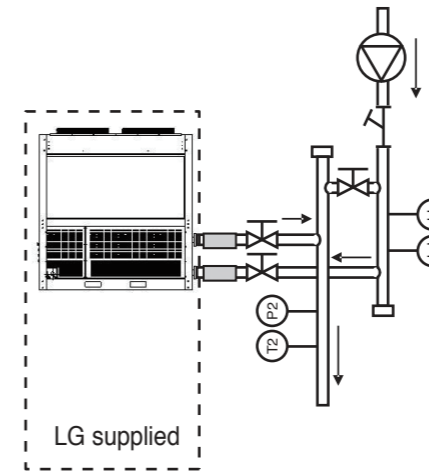

### • Independent product installation

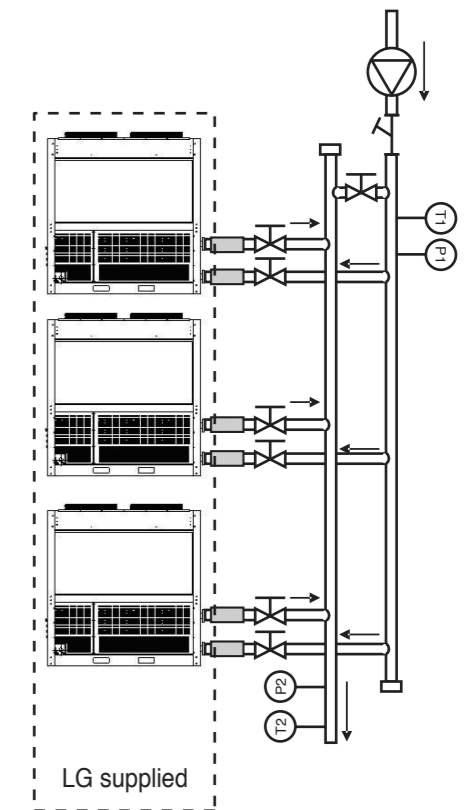

Symbol	Description
	Valve
	Strainer
	Flexible joint

Symbol	Description
T1	Temperature sensor(1: Inlet 2: Outlet)
P1	Pressure gauge(1: Inlet, 2: Outlet)
	Cold water pump

## Installation mode B

### • Independent product installation

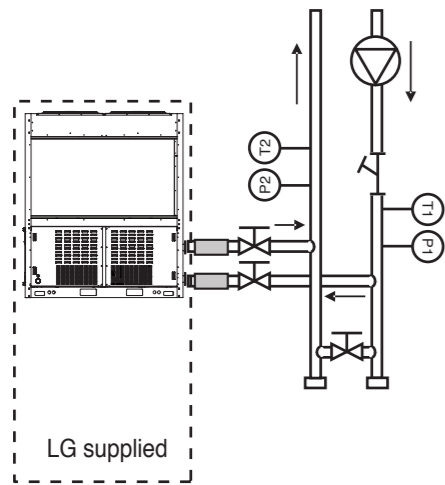

### • Independent product installation

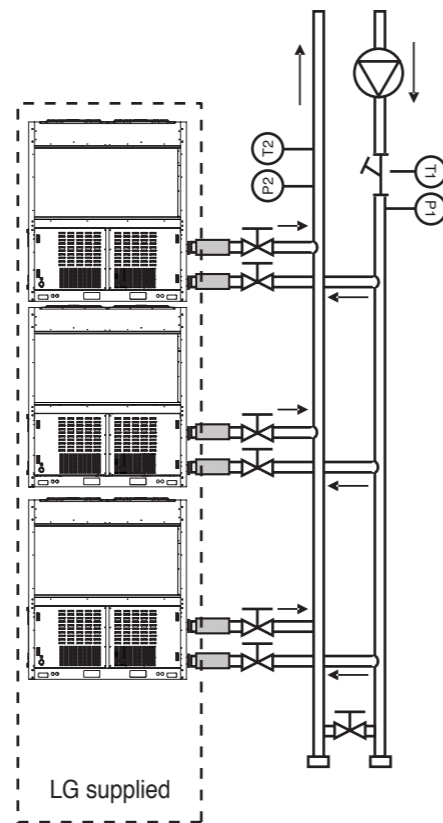

Symbol	Description
	Valve
	Strainer
	Flexible joint

Symbol	Description
T1	Temperature sensor(1: Inlet 2: Outlet)
P1	Pressure gauge(1: Inlet, 2: Outlet)
	Cold water pump

### CAUTION

- If the winter outdoor temperature is 0°C or below, take following measures to prevent the pipe from freezing as shown below.
- If the outdoor temperature is low, the circulation water can freeze to damage the heat exchanger of the product when the product is stopped. If there is possibility of damage from low outdoor temperature, operate the pump to prevent the water from freezing.
- If the product does not operate for a long period of time during the winter season, remove all the circulation water to prevent the damage of heat exchanger and pipe from freezing.
- Add anti-freeze additive to prevent the circulation water from freezing during the winter season.
- Maintain the cold water flux within the designed flux to ensure appropriate chiller performance and reduce the tube damage from rusting, scaling and corrosion. LG is not responsible for any damage of chiller from poor water quality management or inappropriate processing water.

### Water pipe installation

- Appropriate pressure of pipe connection is flange connection of 1 MPa or below.
- Size of the water pipe must be the same as that of the product or larger.
- If there is risk of dew drops forming, always install the thermal insulation material on the outlet pipe of the cold water.
- To avoid connected water pipe from creeping from the load, use appropriate hook for support.
- To prevent the pipe connected part from freezing during the winter season, always install the drain valve at the most bottom of the pipe system.
- Cold water inlet pipe is located at the bottom and the outlet pipe is installed on the top.
- When connecting several chillers, refer to the following for common pipe size.

### ACAH Series

Full product capacity	20 RT	40 RT	60 RT	80 RT	100 RT	120 RT	140 RT
Common pipe size	65 A	80 A	100 A	100 A	125 A	125 A	125 A
Product	20 RT	•					
	40 RT		•		••	•	••
	60 RT			•		•	••

Full product capacity	160 RT	180 RT	200 RT	220 RT	240 RT	260 RT	280 RT	300 RT
Common pipe size	150 A	150 A	150 A	200 A	200 A	200 A	200 A	200 A
Product	20 RT							
	40 RT	•		••	•	••	•	
	60 RT	••	•••	••	•••	••••	•••	••••

### ACHH Series

Full product capacity	20 RT	40 RT	60 RT	80 RT	100 RT	120 RT	140 RT
Common pipe size	65 A	80 A	100 A	100 A	125 A	125 A	125 A
Product	20 RT	•	•	•	•	••	••
	40 RT		•	•	••	••	•••

  

Full product capacity	160 RT	180 RT	200 RT	220 RT	240 RT	260 RT	280 RT	300 RT
Common pipe size	150 A	150 A	150 A	200 A	200 A	200 A	200 A	200 A
Product	20 RT	•		•		•		•
	40 RT	••••	••••	•••••	•••••	•••••	•••••	•••••

### Water pump control

- If the cold water pump is not operating for a long period of time or if the anti-freeze liquid is not used as the cold water, the anti-freeze pump control must be installed to prevent the pipe from freezing.
- The vibration of the pump can transfer to the pipe to cause noise indoors. As the plan to prevent the noise from spreading in the pump, install flexible joints at the inlet/outlet and use the anti-vibration amount for the pump support.

## Unit Combination

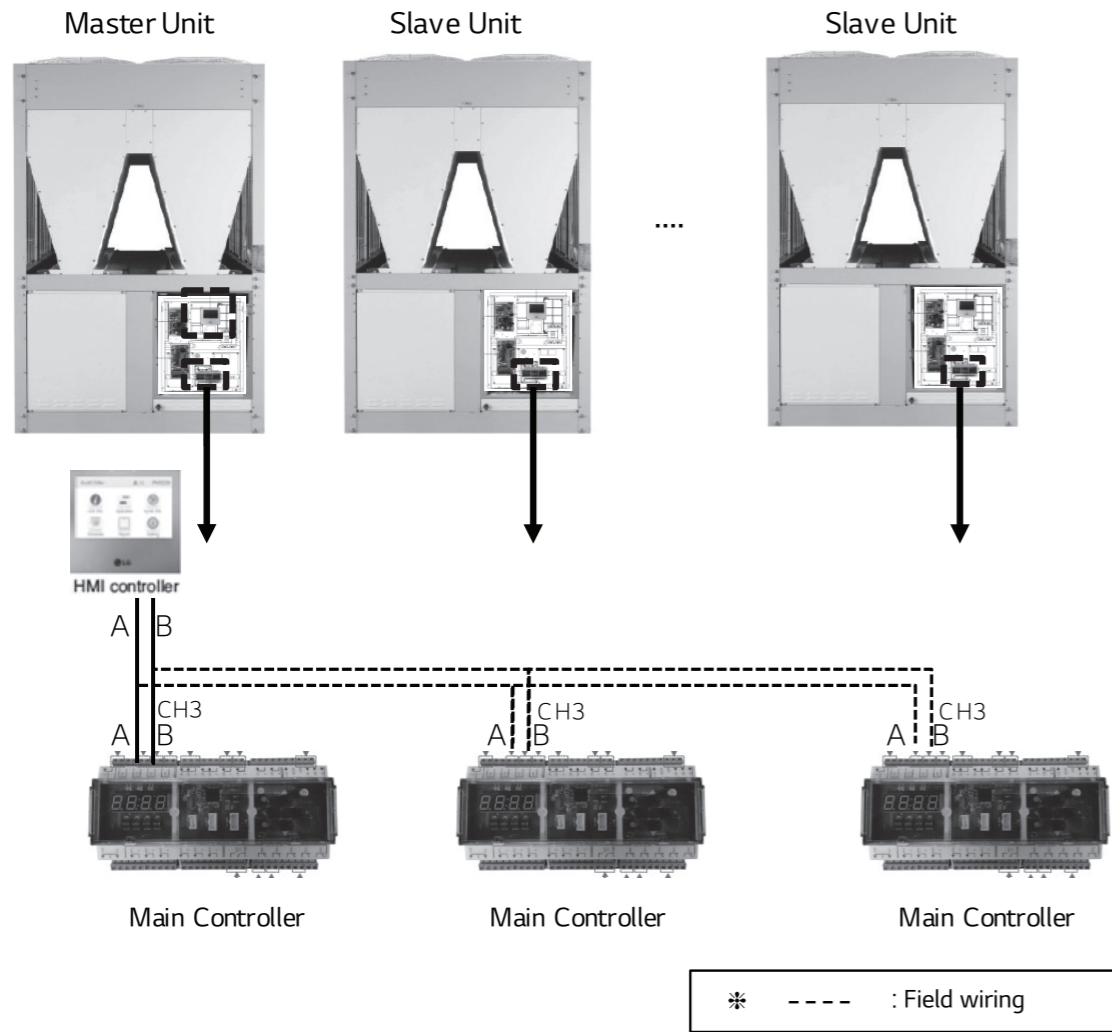

- 1) Communication line is divided A into B like a picture and is jump connected to Main Unit and Main Controller CH3 of Slave unit.
- 2) Communication line jump connected is divided A into B to HMI of Master Unit and in connected.
- 3) Use 2-line shield as a communication line
- 4) Separately install the communication and power cable of the chiller so that communication cable is not affected by the electric noise generated from power cable(Do not pass through the same electric pipe)
- 5) Unit combination is able to connect up to 5 units.

### ⚠ WARNING

If number and address of product to want to interlock is not set from HMI, Error will occur.(please refer to control>freezer interlocking control about HMI address setting)

If Main Controller address doesn't match HMI address, Error will occur. (please refer to control>freezer address setting about Controller address setting)

# Guide Specification(ACAH Series)

## Contents

1. Casing
2. Compressor
3. Condenser
4. Electronic expansion valve
5. Evaporator
6. Control equipment
7. Ref. piping
8. Safety devices



## Manufacturing specification

- 1) Use parts and materials of KS standard or equivalent for chillers not specified in this specification, and all parts should be designed with structure that is easy for replacement, repair, and inspection.
- 2) If there is a problem in the chiller, or if there is an abnormal status of chilled water temperature and flow amount, etc., immediately stop the chiller operation and you have to be equipped with certified equipment or function that can easily be identified.
- 3) There should be a protection circuit to prevent chiller damage from blackout or frequent voltage variation from power plant.
- 4) Chiller should be able to operate silently without abnormal noise or abnormal vibration.
- 5) Chiller should be composed of the central controller and the circuit possible for wired/wireless Start/Stop operation.
- 6) Easy combination should be possible with compact and module type design.
- 7) It should be the structure possible for back-up operation even if compressor or some parts fail and cooling operation should be available during parts replacement, repair, or inspection.
- 8) The main power cable with equivalent or above the specification presented in the product specification of each corresponding model should be used for the chiller, each communication line and power cable should use cable pipe for protection, and the cable pipe with the material that can block external electrical noise according to the installation environment should be used.

## Air cooled type scroll chiller product specification

### 1. Casing

- 1) It should have the structure that is easy for disassembly and assembly for easy maintenance/repair.
- 2) It should have a good looking exterior and it should be insulated to prevent condensation.
- 3) It should have the structure preventing vibration and abnormal noise.
- 4) It should have the structure that can be grounded.

### 2. Compressor

- 1) R410A refrigerant shall be used in compressor whose casing shall be completely sealed hermetic type. Combination of two inverter scroll compressors shall be provided which shall be adjusted for soft loading, and shall be a high efficiency compressing system that can optimize energy consumption by using inverter control.
- 2) Vibration prevention rubber should be used to prevent transferring noise and vibration during operation.
- 3) The frequency variable boundary of inverter scroll compressor

shall be minimum 30Hz and maximum 127Hz.

- 4) Alternating operation should be possible to have the uniform average operation time for each compressor.

### 3. Condenser

- 1) Condenser heat exchanger shall be used with purity 99.9 % or above Phosphorus Deoxidized Copper without joint, and it shall have the structure with Al fin attached to increase the heating area.(Cross fin & Tube type)
- 2) Use wide louver fin for Al fin, and pipe extension shall be carried out for efficient heat transfer.
- 3) Condenser air cooled type heat exchanger arrangement shall be 3 rows, 48 levels of 14FPI.
- 4) Pressure test for high pressure part in refrigerant side should be carried out at 4.18 MPa or above(Designed pressure 3.8 MPa), and there should not be problems such as leakage or deformation.
- 5) Condensing coil that passed pressure test should be vacuumed to completely remove moisture inside.
- 6) Use propeller type Fans, which should be able to provide sufficient air flow required for cooling. Also, it should have sufficient strength for rotating speed, and should be operated silently through balance test.
- 7) Motor should be BLDC type that can increase efficiency.
- 8) Fan shall be connected directly to driving motor.

### 4. Electronic Expansion Valve

- 1) It is used at adiabatic-expansion process in refrigeration cycle and expands high pressure fluid refrigerant at condenser exit converting to low temperature / low pressure state, and linear electronic expansion valve shall be activated to adjust refrigerant amount according to evaporator load during cooling operation.
- 2) Based on data from various sensors installed in the chiller, micro-computer shall be able to analyze operation status of the system and compressor shall control the optimum refrigerant amount linearly.
- 3) By applying electric pulse signal to stepping motor, it shall be able to play a role of adjusting refrigerant flow amount.

### 5. Evaporator

- 1) Evaporator shall be shell & tube type heat exchanger, and the material shall be carbon steel for shell and copper for tubes.
- 2) There should be no water leakage, and the durability should be guaranteed.
- 3) It should have the structure that can connect to chilled water pipe.
- 4) Heat exchanger should be robust structure not allowing that the refrigerant and coolant are not mixed.
- 5) It shall be a DX type heat exchanger that refrigerant flows inside tubes and water flows inside shell. Chemical cleaning should be conducted periodically for protective

maintenance of chillers.

- 6) As a standard, the evaporator shell is insulated with NBR (Nitrile-Butadiene Rubber) of 3/4"(19mm) thickness and black color.

### 6. Control equipment

- 1) Controller operates overall system in optimal condition with a micro-computer unit installed in the chiller, and based on the 4 measured values such as suction gas pressure, discharge gas pressure, discharge gas temperature, and heat exchanger refrigerant temperature, it shall be able to control electronic expansion valve and compressor(Inverter driven), etc.
- 2) There should be a function that can check all sensors connected to the chiller and various operation status.
- 3) It should be equipped with self-protection devices and system protection function.
- 4) Module type control interface shall be applied so that simple product control is possible in series installation, and relocation and re-installation of HMI controller shall be possible without shifting other control devices.

### 7. Refrigerant Piping

- 1) Refrigerant pipe shall be made of purity 99.9% or above Phosphorus Deoxidized Copper without joint, and it should be connected for fluent refrigerant flow between each component.
- 2) Check valve at compressor discharge side to prevent reverse flow of the discharged refrigerant shall be installed.
- 3) Strainer in the pipe to prevent solid bodies or particles from mixing in a liquid stream shall be installed.
- 4) The pipe from expansion valve to evaporator should be insulated to prevent moisture condensation on the surface of the pipe and to prevent flash gas generation from refrigerant fluid at the same time.

### 8. Safety devices

- 1) Refrigerant pressure(Normal refrigerant pressure)
  - A. High pressure switch
  - B. High voltage protection(Sensor)
- 2) Temperature
  - A. compressor discharge temperature superheating detection(Sensor)
  - B. IPM temperature detection(Sensor)
  - C. Chiller and burst protection(Sensor)
  - D. Power Module application(Sensor)
- 3) Chilled water flow
  - A. Chilled water flow switch
- 4) Voltage and current(Control logic)
  - A. Revere phase detection and protection (Voltage monitoring system)
  - B. Compressor over-current protection
  - C. Fan motor over-current protection



# Guide Specification(ACHH Series)

## Contents

1. Casing
2. Compressor
3. Condenser
4. Electronic expansion valve
5. Evaporator
6. Control equipment
7. Ref. piping
8. Safety devices



## Guide specification



### Manufacturing specification

- 1) Use parts and materials of KS standard or equivalent for chillers not specified in this specification, and all parts should be designed with structure that is easy for replacement, repair, and inspection.
- 2) If there is a problem in the chiller, or if there is an abnormal status of chilled water temperature and flow amount, etc., immediately stop the chiller operation and you have to be equipped with certified equipment or function that can easily be identified.
- 3) There should be a protection circuit to prevent chiller damage by blackout or frequent voltage variation from power plant.
- 4) Heat pump should be able to operate silently without abnormal noise or abnormal vibration.
- 5) Heat pump should be composed of the central controller and the circuit possible for wired/wireless Start/Stop operation.
- 6) Easy combination should be possible with compact and module type design.
- 7) It should be the structure possible for back-up operation even if compressor or some parts fail and cooling operation should be available during parts replacement, repair, or inspection.
- 8) The main power cable with equivalent or above the specification presented in the product specification of each corresponding model should be used for the chiller, each communication line and power cable should use cable pipe for protection, and the cable pipe with the material that can block external electrical noise according to the installation environment should be used.

### Air cooled type scroll heat pump product specification

1. Casing
  - 1) It should have the structure that is easy for disassembly and assembly for easy maintenance/repair.
  - 2) It should have a good looking exterior and it should be insulated to prevent condensation.
  - 3) It should have the structure preventing vibration and abnormal noise.
  - 4) It should have the structure that can be grounded.
2. Compressor
  - 1) R410A refrigerant shall be used in compressor whose casing shall be completely sealed hermetic type. Combination of two inverter scroll compressors shall be provided which shall be adjusted for soft loading, and shall be a high efficiency compressing system that can optimize energy consumption by using inverter control.
  - 2) Vibration prevention rubber should be used to prevent transferring noise and vibration during operation.

- 3) The frequency variable boundary of inverter scroll compressor shall be minimum 30Hz and maximum 127Hz.
- 4) Alternating operation should be possible to have the uniform average operation time for each compressor.
- 5) If multi-compressor is installed at the product, machine should keep operating when any compressor is in malfunction or trouble. Compressor can be replaced after stopping operation of machine. At this time, abnormal condition of the compressor should be confirmed by user through system controller.

### 3. Air Side Heat Exchanger(Condenser)

- 1) Condenser heat exchanger shall be used with purity 99.9 % or above Phosphorus Deoxidized Copper without joint, and it shall have the structure with Al fin attached to increase the heating area.(Cross fin & Tube type)
- 2) Use wide louver fin for Al fin, and pipe extension shall be carried out for efficient heat transfer.
- 3) Condenser air cooled type heat exchanger arrangement shall be 3 rows, 48 levels of 14FPI.
- 4) Pressure test for high pressure part in refrigerant side should be carried out at 4.18 MPa or above(Designed pressure 3.8 MPa), and there should not be problems such as leakage or deformation.
- 5) Condensing coil that passed pressure test should be vacuumed to completely remove moisture inside.
- 6) Use propeller type Fans, which should be able to provide sufficient air flow required for cooling and heating. Also, it should have sufficient strength for rotating speed, and should be operated silently through balance test.
- 7) Motor should be BLDC type that can increase efficiency.
- 8) Fan shall be connected directly to driving motor.

### 4. Electronic Expansion Valve

- 1) It is used at adiabatic-expansion process in refrigeration cycle and expands high pressure fluid refrigerant at condenser exit converting to low temperature / low pressure state, and linear electronic expansion valve shall be activated to adjust refrigerant amount according to evaporator load during cooling operation.
- 2) Based on data from various sensors installed in the chiller, micro-computer shall be able to analyze operation status of the system and compressor shall control the optimum refrigerant amount linearly.
- 3) By applying electric pulse signal to stepping motor, it shall be able to play a role of adjusting refrigerant flow amount.

### 5. Water Side Heat Exchanger(Evaporator)

- 1) Evaporator shall be shell & tube type heat exchanger, and the material shall be carbon steel for shell and copper for tubes.
- 2) There should be no water leakage, and the durability should be guaranteed.

