



Ver. 202004



LG Electronics, Home appliance & Air solution company

56, Digital-ro 10-gil, Geumcheon-gu, Seoul, Republic of Korea (153-801)

www.lg.com

www.lgeaircon.com

LG HVAC SOLUTION

CENTRIFUGAL CHILLER

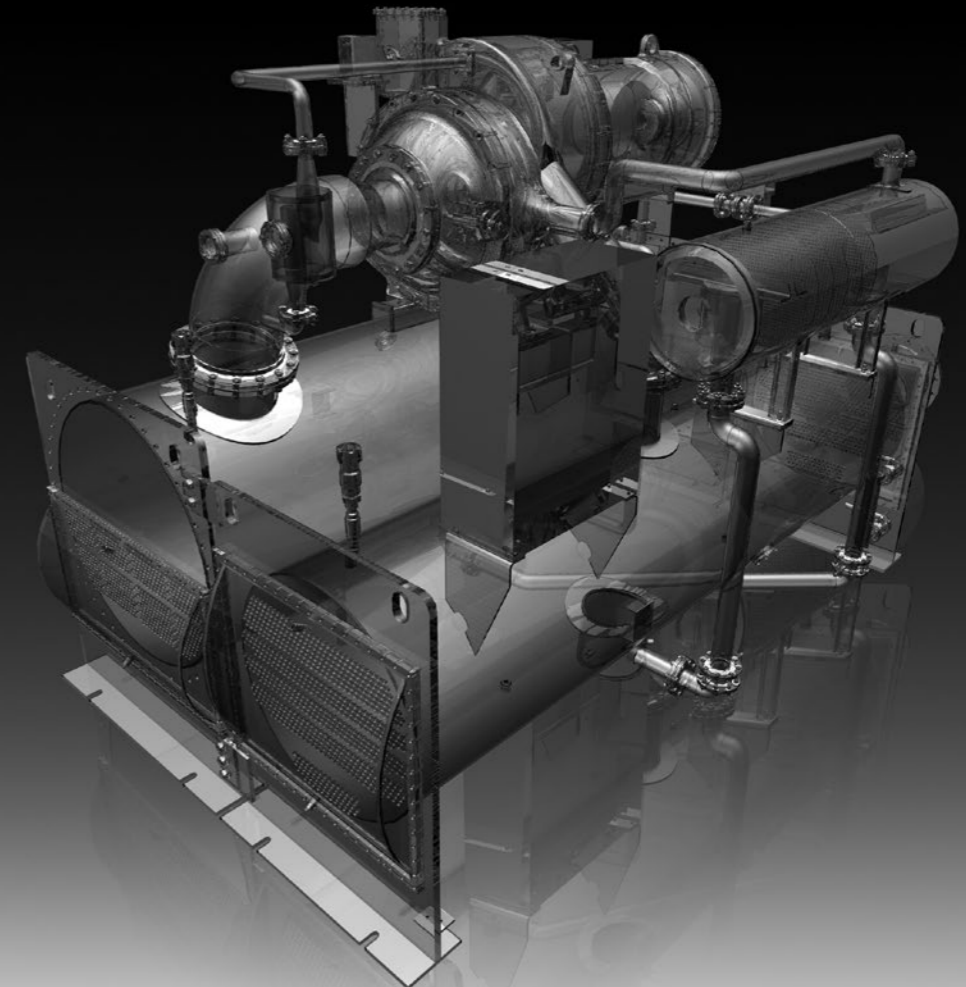

For continual product development, LG reserves the right to change specifications or designs without notice.

© 2020 LG Electronics. Printed in Korea. Apr. 2020

Distributed by

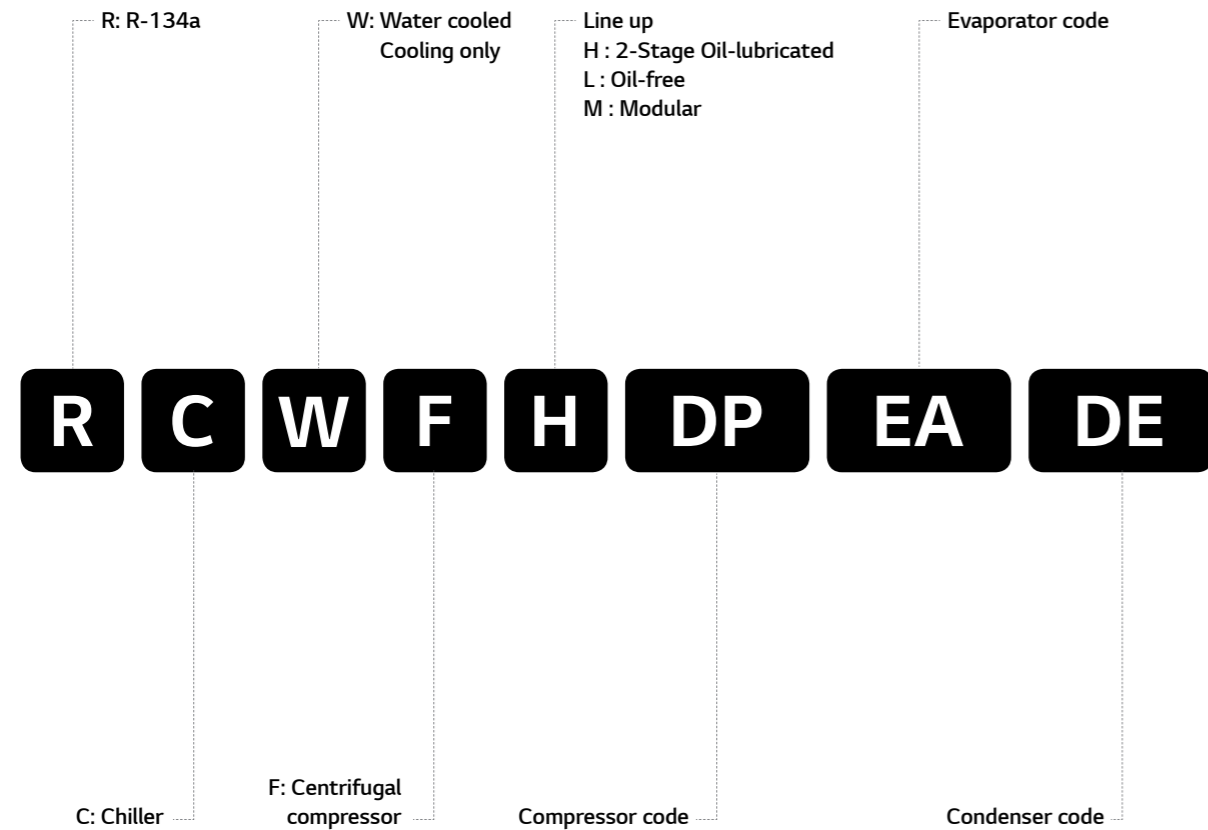

Contents

- 02 Nomenclature
- 03 Line up & Introduction
- 04 Equipment overview
- 07 Control
- 11 Refrigerant cycle
- 12 Lubrication system
- 13 Safety devices
- 14 Accessories and options
- 15 Machine outline
- 16 Specification
- 21 Machine components
- 24 Typical piping & Wiring
- 25 Insulation
- 26 Guide specification

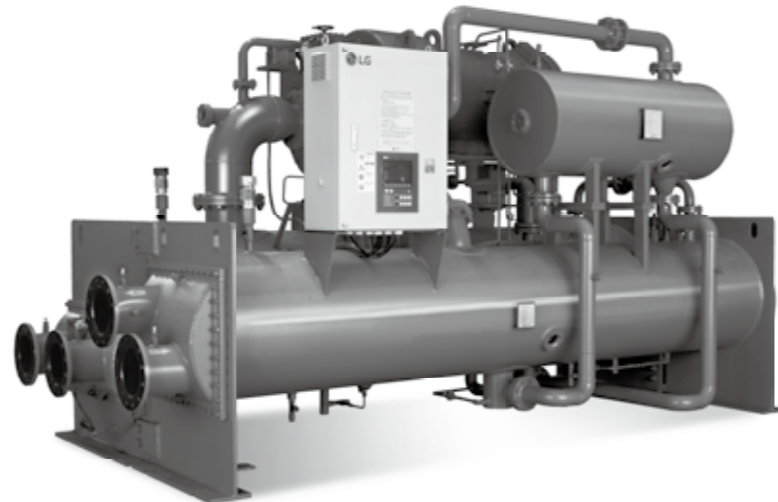

Line up

Model	100	200	300	400	500	1,000	2,000	3,000	3,400
R-134a 2-Stage		200RT						3,000RT	

* The above range is based on the nominal tonnage.

World class high efficiency

The advanced technologies of LG achieve the lowest energy consumption and preserve the environment.

LG chiller offers high-efficiency chlorine-free water-cooled centrifugal chillers using HFC-134a refrigerant. Over three decades of chiller manufacturing and experience in HVAC industry, it has significantly reduced the power consumption of centrifugal chiller with positive-pressure refrigerant HFC-134a, and introduces most cost effective & reliable solutions to all valuable customers. Decreasing hydraulic-head helps to minimize energy loss even further.



Advanced solution for saving energy

The chiller using a two stage compressor developed by the technology of LG increases energy efficiency by 10% ~ 13% at full load conditions as compared to the chiller with single stage compressor, and increases energy efficiency under partial load conditions by 24% or more.

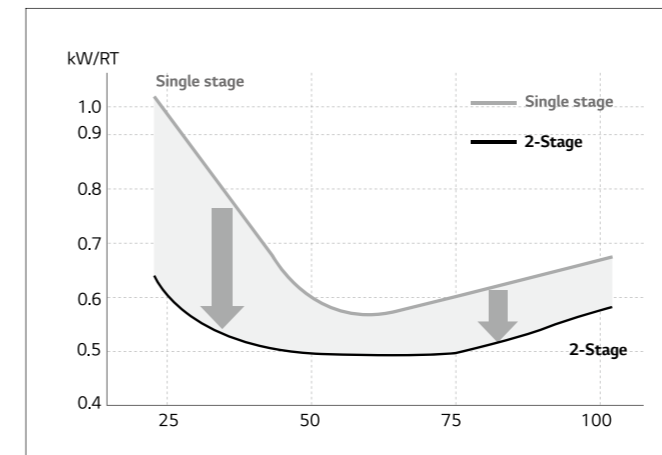

Eco-friendly chiller

The LG chillers use chlorine-free HFC-134a refrigerant having zero ozone-depletion potential. LG chiller will work as an excellent harmony with environmental friendly facilities.

Saving installation space

LG's optimized chiller design using positive pressure refrigerant minimizes the machine room space and so return a valuable extra space and a cost saving to the customers.

Simple bolting Structure

The evaporator, condenser, and compressor are final-assembled with simple bolting and flange connections, LG chiller provides an excellent solution for the retrofit and replacement jobs where are critical difficulties in an installation works within a limited space.

High reliability

LG chillers are designed through 3-dimensional and various dynamic analysis and it increased the reliability.

All components were reliable test and also exclusively selected and manufactured. Factory-run-test are available for all chillers to make sure quality ensurance before factory out as an option by customers.

Optimized & user-oriented control

LG unit controller, LGC-X30 was developed based on advanced algorithm, convenient and reliable control concept.

Also it provides various customer-oriented functions; graphical display of key data, operation scheduling, help menu for easy trouble shooting, three language support, various industrial standard interface protocols and more.

AHRI certification program

LG chillers has been certified to the air conditioning and refrigeration Institute(AHRI) as complying with the certification sections of the latest issue of AHRI Standard 550/590.



Under this certification program, chillers are regularly tested in strict compliance with this standard. This provides an independent, third-party verification of chiller performance.

Standards and codes

- AHRI 550/590 - Water chilling packages using the vapor compression cycle.
- ANSI/ASHRAE 34 - Number designation and safety classification of refrigerants.
- ASME section VIII - Boiler and pressure vessel.
- CE - Conform to CE testing services for construction of chillers and provide CE listed mark.
- GB/T 18430.1 - Water chilling(Heat pump) packages using the vapor compression cycle - Part 1: Water chilling(Heat pump) packages for Industrial & commercial and similar applications.
- GB25131 - Safety requirements for water chillers(Heat pump) using the vapor compression cycle.
- GB150/151 - Steel pressure vessels/tubular heat exchangers.
- ANSI/ASHRAE Standard 15 safety code.
- Manufactured in an EN ISO 9001 accredited organization.
- ETL – Conforms to ANSI/UL STD 1995 certified to CAN/CSA STO C22.2.
- N.E.C. – National Electrical Code.
- OSHAS 18001 – Occupational safety and health act.



The test facility has obtained AHRI 550/590 certification.

Unit performance test

LG has established one of the largest chiller testing facility in the world.

Each LG chiller is thoroughly tested prior to shipment, and is delivered to the customer with full test data included.

Performance test facilities are able to test up to 3,000RT, 13.8kV and also available to accurately recreate a wide variety of environmental conditions, helping the company to tailor its products to the greatest number of markets.

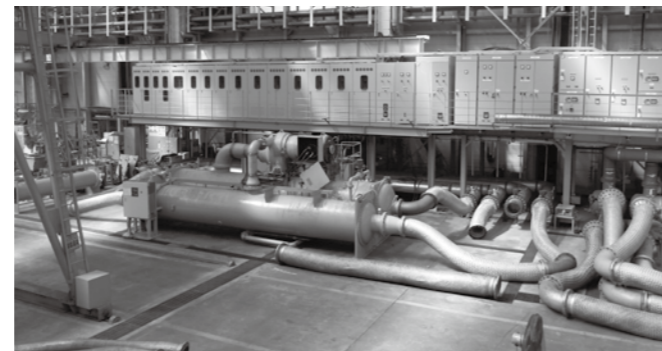

Performance test facilities

Equipment overview

Two stage compressor design

LG Chiller uses simple, compact and economic two stage design with two impellers, variable diffuser and economizer. When operating at light loads with high condensing temperatures, it happen unstable operation, called "surge". But two stage compressor is avoided with two stage design because two stage compressor has wide range of operation. Two stage compressor is possible to flash refrigerant gas at two intermediate pressures between the evaporator and condenser, significantly increasing chiller efficiency. The improvement of efficiency is not available for single stage chiller because all compression is done by single impeller.

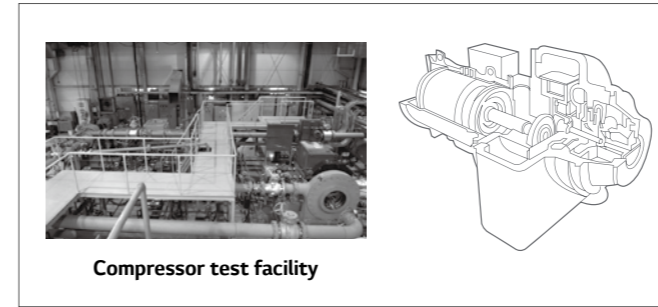

Compressor test facility

Inlet guide vanes

LG chiller adopts IGV(Inlet Guide Vanes) for the capacity control.

However, the vane opening is precisely controlled by a modutrol motor. Precise and smooth control of the chilled water temperature can be provided with this simple device.

It adjusts the refrigerant mass flow rate taken through the compressor inlet to adjust the capacity of the chiller, and it adjusts the opening of the vanes using the external actuator. The amount of refrigerant taken in is adjusted according to the set of chilled water outlet temperature.

Variable diffuser

Provides wider operation range at a low-load condition, and prevents stall from discharge gas for stable operation.

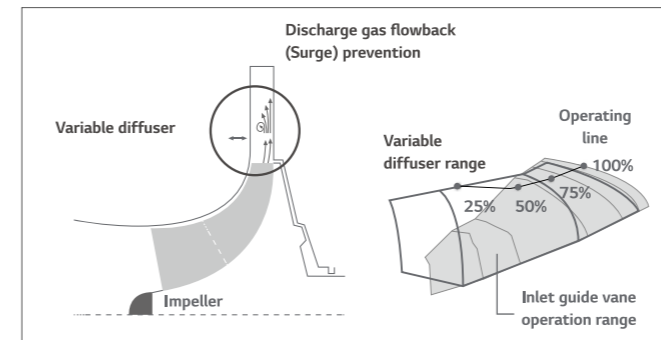

Bearing

1. Compressor type : AA ~ EK
 - Ball bearing is composed of isolated bearing on motor shaft and angular contact bearings on the impeller shaft.
 - Ball bearing structure is subjected to a radial and axial load at the same time.
 - Because of less oil flow rate for ball bearings, the rotor dynamic system can be designed with compact size.
2. Compressor type : F1 ~ G3
 - Bearing is composed of bearing in motor shaft, radial bearings and thrust bearings on the impeller shaft.
 - Bearings with white metal are used to achieve persistence and corrosion resistance. Lubrication system prevents bearings from Metal-to-Metal contact during operation.
 - To increase the reliability of the journal bearings, Offset type

and 3-Lobe type bearings are applied.

Aerodynamically-shaped impeller

Impellers that utilize 11 back sweep main blades and 11 splitters are aerodynamically shaped to improve compressor efficiency. The blade 3D profiles are designed by using 3D-CFD(Computational Fluid Dynamics) and design database based on compressor tests.

- The vane of impeller designed aerodynamically based on the 3D fluid analysis, guarantees the reliability in any operational condition.
- To minimize vibration, the impeller shall be balanced dynamically. Overall reliability of impellers shall be secured by taking the strength test, hardness test, non-destructive test, etc. for all impellers produced.

Low solidity airfoil diffuser

Using simple 2D airfoils, the low solidity diffuser increases compressor peak efficiency and widen operating range with no moving parts.

Robust rotor dynamic system and transmission

High speed rotating system including bearings are designed to secure the robust operating over the life of the machine at various load conditions.

Oil pump

The oil pump is driven by an electric motor from the separate power source to prevent the lubrication failure due to abnormal compressor shutdown. It delivers fluent oil to the gears and the 4 bearings when compressor start-up and normal operation.

Oil heater

High speed rotating system including bearings are designed with oil heater installed in the oil sump which is mainly used to dry out the refrigerant mixed in the reclaimed oil from the transmission and the evaporator. Also, the heater prevents the abrupt mix of oil and refrigerant while compressor shutdown and pre-heats the oil before start-up. All the operation of the heater is controlled by the microprocessor controller.

Oil cooler

A compact refrigerant-oil heat exchanger is used for the oil cooler. The liquid refrigerant can be a safe and effective cooling source in the system. A small amount of liquid refrigerant is extracted at the bottom of the condenser and it cools the hot oil(After lubricating the rotor dynamic system) at the heat exchanger and returns to the evaporator.

Oil reservoir

During the power failure, oil reservoir shall automatically supply oil for compressor bearings to prevent any compressor damage.

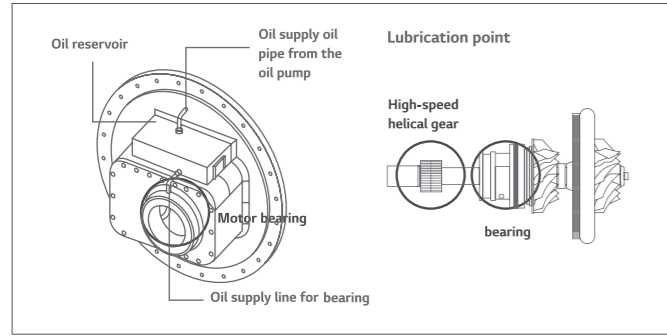

Refrigerant-cooled Semi-hermetic Motor

The motor is bolt-connected to the compressor gear housing and the shaft labyrinth seal prevents refrigerant leakage from the motor to the gear box. This semi-hermetic motor is more compact and makes less noise than the air-cooled motor. No heat is ejected to the machine room. No expensive mechanical seal is required. Using motor shaft as a bull gear shaft, no coupling is needed and it minimizes the shaft alignment problems. Like oil cooler, the motor is cooled by the condensed liquid refrigerant, so that the motor wiring can keep low temperature to improve motor efficiency. The liquid refrigerant is sprayed to the several stator locations of the motor for efficient cooling. The optimum locations and the liquid flow rate is designed by a lot of motor tests.

Heat exchangers

Heat exchanger of two-stage centrifugal chiller is composed of two shell type for easy separation into evaporator and condenser. The tubes are arranged so as to maximize the heat exchanging ability. It is also designed so that the refrigerant can be spread evenly on all tubes for the sake of surge prevention and the COP increase in part load operation. Efficiency increasing purpose sub cooler is adopted for the subcool of the condensed refrigerant.

A relief valve for an abnormal situation is at the upper part of the heat exchanger.

High performance tubes

Heat transfer coefficients on inner surface are significantly enhanced by selecting optimal ridge size and angle without sacrificing pressure drop. In addition, Enhancement of heat transfer on outer surfaces are respectively designed and tested for easy condensation and evaporation.

Effectively-designed Condenser

LG condenser has a baffle to prevent direct impingement of high-velocity refrigerant gas on the tube surface and thus eliminate the related vibration and noise. Cooling water flows into sub-cooler from cooling tower and flows to upper part of condenser. This helps to enlarge chiller capacity and increase system efficiency.

Durable heat exchanger

Expansion of tube in double-grooved hole at tube sheet prevents leakage and increases durability of heat exchanger.

Isolation valves of refrigerant filter

This valve allows us to replace filter without pump-down of refrigerant. This is installed for less service time and less maintenance cost.

Pressure vessel(Options)

The evaporator and condenser can be provided with either ASME or PED pressure vessel codes as an option and KS pressure vessel design is standard.

Expansion device and economizer

The condensed refrigerant liquid passed the 1st expansion device enters the economizer where refrigerant gas and liquid are segregated. The refrigerant gas is mixed with mid-temperature, mid-pressure gas compressed in the 1st impeller. The refrigerant liquid goes through 2nd expansion device to be taken into evaporator. The mid-temperature and mid-pressure gas between the 1st and the 2nd impeller become cool by mixing with the cool refrigerant gas supplied from economizer before sucked in to the 2nd impeller. As such, when the 2nd impeller discharge gas temperature is decreased by mixing gas from economizer with discharge gas from 1st impeller, power consumption required by compressor is decreased(Increasing cycle efficiency). The efficiency increase much higher than by the 1 Stage compressing method.

Microprocessor-based controls

LG's Microprocessor-based controller, LGC-X30 enables the user to monitor and control the chiller with high-class accuracy and confidence. The exclusively designed algorithm allows the optimized operation.

LGC- X30 controller is ready for multi-language support; Chinese, English and Korean. Max. 8 units of LG chiller can be linked together and controlled through only 1 protocol converter(Optional).

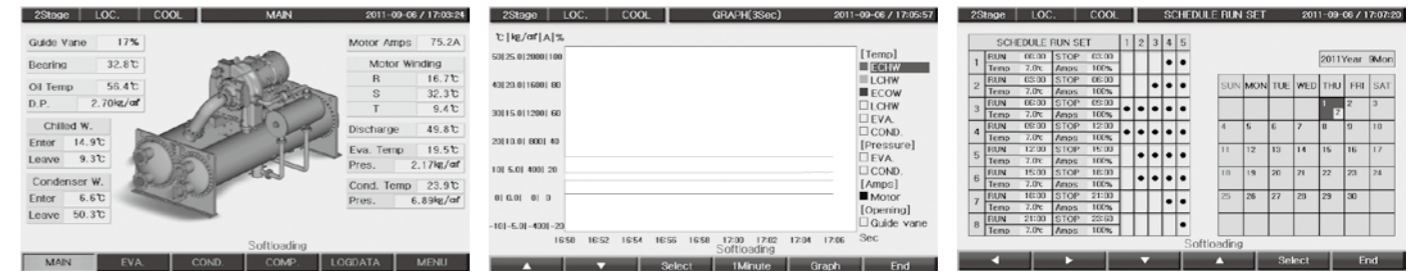
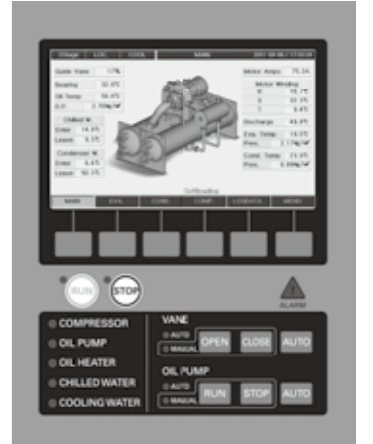

7" Color LCD with high resolution

Operation data trend

Reserve operation

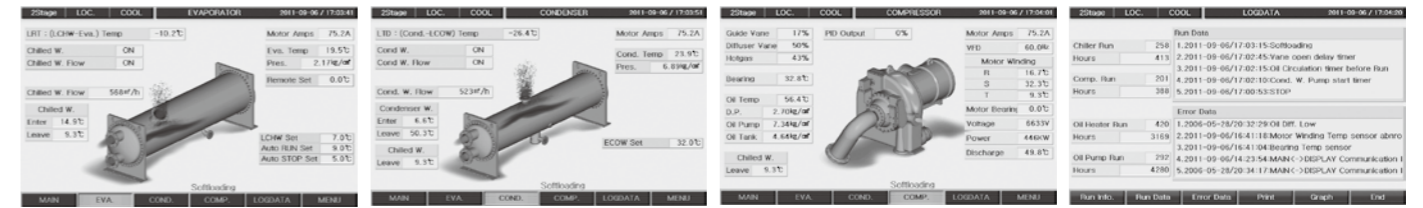

State of evaporator

State of condenser

State of compressor

Operation history

AC Smart premium

- 10.2-inch color LCD touch screen with high resolution(1,024 x 600)
- Operation scheduling function
- Real time trend display
- Web Access(Additional accessory)
- Running data acquisition
- Easy-to-read display of operational data
- Certified EMI/EMS
- Communication supported: Modbus, RS485(Standard)
- Language: English / Chinese / Korean



Microprocessor controls

The unit controller is factory mounted, wired and tested before shipment. And a built-in printer, BACnet, Modbus protocol converter module and Modem are equipped as an option.

Safety cutouts

The all safety control inputs and, if required, shuts down the chiller or limits the guide vanes to protect the chiller from possible damage from and of the following conditions:

- High bearing temperature
- High motor winding temperature
- High discharge temperature
- Low oil pressure
- Low cooler refrigerant temperature/pressure
- Condenser high pressure or low pressure
- Inadequate water cooler and condenser flow
- Excessive motor acceleration time
- Excessive starter transition time
- Lack of motor current signal
- Excessive motor amps
- Excessive compressor surge
- Temperature and transducer faults
- Soft start system
- Soft stop system
- Control circuit fuse
- Control module fuse
- Oil heater fuse
- Oil pump motor fuse
- Safety relief valve

Main menu indications(Control center)

- Run Mode Set
- User Set
- Manual Control
- Schedule Set
- Service Menu
- Run Data Check
- Error Data Check
- Pager Mode Set
- System Menu
- Bright Control

Basic display items

- Chilled water inlet & outlet temperatures(°C)
- Cooling water inlet & outlet temperatures(°C)
- Compressor discharge temperature(°C)
- Compressor bearing temperature(°C)
- Oil tank temperature(°C)
- Motor windings(R.S.T) temperatures(°C)
- Evaporator pressure(kg/cm²)
- Condenser pressure(kg/cm²)
- Oil tank pressure(kg/cm²)
- Oil pump pressure(kg/cm²)
- Amperes(A)
- Voltages(V)
- Watts(kW)
- Chilled water flow(m³/h)fR
- Cooling water flow(m³/h)fR
- Vane openings(%)
- Remote setting temperature(°C)
- Evaporator temperature(°C)
- Condenser temperature(°C)
- Differential pressure of oil(kg/cm²)
- Hot-gas valve output(%)
- Frequency of cooling tower fan inverter(Hz)
- PID output(%)
- Control output(%)
- Real setting value(°C)

• These items are optional.

User settings

- Chilled outlet temperature(7°C)
- Compressor current limit(100%)
- Guide vane high limit(50%)
- Cooling mode P & I & D(6.8°C, 300 sec., 3.0 sec.)
- Hot-gas valve- Vane %(30%)
- Hot-gas valve max.(100%)
- Hot-gas valve min.(0%)
- Chilled water brine temperature(-5.0°C)
- Cooling tower fan RUN(32.0°C)
- Cooling tower fan STOP(28.0°C)
- Cooling tower fan STEP(1.0°C)
- Cooling tower fan delay(60sec)
- Cooling water inlet temperature(31.0°C)
- Cooling tower fan P & I & D(4.0°C, 400sec, 20.0 sec.)
- Operational data log time(60 sec.)

- Year
- Month
- Date
- Week
- Hour
- Minute
- Second
- LCD light on time(60 sec.)

• The values in() are default setting values.

Main menu indications(Control center)

- Run Mode Set
- User Set
- Manual Control
- Schedule Set
- Service Menu
- Run Data Check
- Error Data Check
- Pager Mode Set
- System Menu
- Bright Control

Control sequence

Start

The chiller is starting to run by pressing the RUN-key on the control center of unit controller; the key must be pressed for 2 seconds as a minimal. During the manual operation, RUN type must be set as "local mode". Second start-up will be activated only after 30 minutes(Expiration of re-start prevention timer) for normal-start or 3 minutes(Expiration of oil pump circulation timer) for auto-stop in order to protect compressor motor.

Firstly, Cooling water pump is running in 5 seconds after chilled water pump starts running. And the chiller will proceed to next sequence only after chilled water and cooling water flows reach enough flow rate. If the chilled water temperature is less than target temperature by 2 degree C, compressor will stop automatically.

When the chiller starts, soft-loading mode is activated to open IGV slowly in order to prevent any damage from compressor. Then the capacity control mode follows. When the compressor stops due to serious trouble, alarm lamp is on, and the shutdown status is displayed on the LCD, and also shutdown information is recorded at RAM of controller.

Stop

The chiller stops under one of the following events:

- The Stop button is pressed for at least 2 seconds or the remote-stop signal is delivered to the controller.
- Auto-stop at " Setting temperature - 2°C "
- Time schedule is stop-mode
- Alarm states

During the stop process, firstly the compressor is forced to stop. The guide vanes are brought to the closed position. The oil pump and chilled water pump stop in 300 seconds after compressor stops and then cooling water pump will stop. The cooling water pump will stop. After that 3 minutes of oil pump circulation timer will count down.

If the stop button is pressed or remote-stop signal is delivered, the guide vanes will close. And the chiller will stop, if the vane full-close limit switch is closed or the vane opening is less than 10% or 4 minutes passed from when the vane starts to close.

Re-start

Restart is activated only after the followings;

- After expiration of re-start prevention timer(30 minutes)
- After expiration of starting oil pump circulation timer (3 minutes)

If the chiller stop due to a safe-stop, the reset button must be pressed before restarting the chiller.

Various interface solutions

Using industrial standard protocol converters, the chiller can be interfaced with BAS(Building Automation System).

The remote monitoring and control of the chillers is possible via BACnet/ Ethernet, BACnet/IP, Modbus, Modem or RS-232C/RS-485.

Advanced PID control

The advanced algorithm provides an optimum control during start, stop of chillers and even normal-operation. The advanced PID control minimizes the overshoot and undershoot during the chiller starts and normal operation, and also enables accurate and quick response to temperature control.

Chilled water temperature reset

The chilled water temperature can be reset locally or remotely to readjust the chilled water outlet temperature and save energy.

Operation scheduling

The user can program the chiller operation schedule to run and

stop the chiller automatically and even chilled water target temperature can be scheduled.

Soft loading

At the start-up, the vane opening is controlled with gradual slow- open to prevent surge, oil foaming and finally to protect compressor. This control lasts until the chilled water temperature reaches the target value.

Preventive control

The preventative control is executed before abnormal-stop point and so unnecessary chiller-stops can be minimized.

Direct control of peripheral equipment

It is possible to control chilled/cooling water pumps and cooling tower fan with direct connection with LG unit controller. The cooling tower fan can be 4-step controlled or PID-controlled, the inverter applied.

Self-diagnosis and help function

Self-diagnosis is always performed before start-up and enables safe operation. And the help function informs the user a proper action to be taken if problem occurs.

Data acquisition & storing

Maximum 300 records of operational data including alarm status can be accumulated. And the data collection interval can be set with every 1 second interval from min. 5 seconds to max. 360 seconds and the alarm data is always stored regardless of setting interval.

Graphical display

Various key data is also displayed graphically and so the user acknowledge the data trend with very convenient and easy ways.

Built-in printer(Optional)

The built- in printer allows the user to check and keep the operational data with hard-copy format.

Password protected

Unauthorized access to the control is protected with random-generated password.

Communication protocol support

- Communication method
 - Basic: RS-485, Ethernet(Optional)
- Protocol
 - Basic: Modbus
 - Option: BACnet, TCP/IP

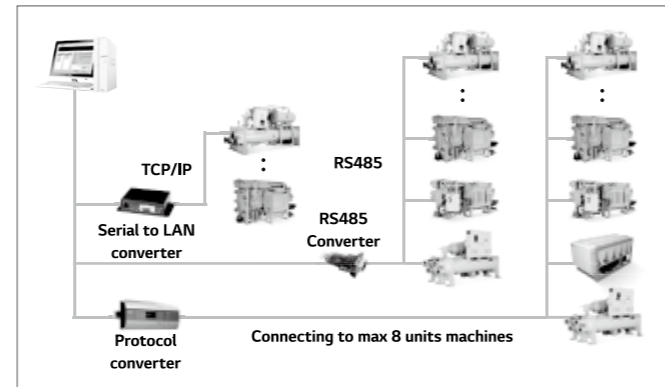

Refrigerant cycle

The two Stage Centrifugal chiller uses environment friendly high pressure refrigerant R-134a.

- In this cycle, as shown in the figure, the vaporized low temperature and low pressure refrigerant gas passes the Inlet Guide Vane, and enters the 1st impeller of the compressor. Since the inlet gas amount is dependent on the guide vane's opening, the chiller capacity can be controlled.
- Refrigerant gas that entered the 1st impeller is compressed to a mid-temperature and mid pressure, passes through the return channel, is mixed with low temperature gas from the economizer, and then enters the 2nd impeller.
- The refrigerant gas entered the 2nd impeller is compressed as high-temperature and high-pressured refrigerant gas, and discharged to the condenser. The gas loses its heat via cooling water in the heat transfer tubes and eventually condensed to liquid.
- The condensed refrigerant liquid passed the 1st expansion device, becomes mixed state and enters the bottom part of the economizer which divides into gas and liquid of refrigerant. The gas part is mixed with the mid temperature and mid pressured gas which was compressed in the 1st impeller, and then enters the 2nd impeller. The liquid part of the refrigerant enters the bottom part of evaporator via 2nd expansion device.
- The liquid refrigerant entered into the evaporator, is then spread into wider surface of evaporator by distributor. Finally the distributed refrigerant is evaporated by taking the heat

from the chilled water inside the evaporator tubes and repeats the cycle.

- Some part of the sub-cooled refrigerant liquid in the condenser, flows through the valve, filter, moisture indicator, and enters the motor and oil cooling system individually.
- The refrigerant liquid flew into the motor is being sprayed so that it can cool the motor's coil and is returned to the evaporator.
- The refrigerant flew into the oil cooling system, flows through the plate type oil cooler. Refrigerant that left the oil cooler is then returned to evaporator.

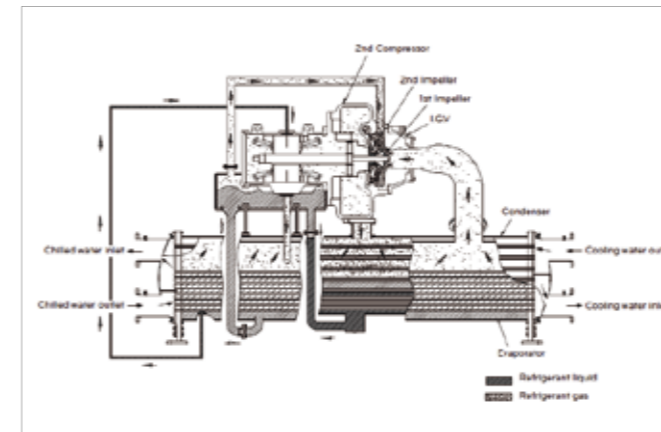

Two stage centrifugal chiller

Lubrication system Introduction

The discharged lubricating oil by the oil pump enters the oil filter to get rid of any unnecessary foreign substance. This oil becomes cooled to the temperature appropriate for operation condition after going through the oil cooler, part of it directly enters gear and high speed side bearings, and the remainder directly enters motor shaft bearings. After the process, it will be drained into the oil tank. The above figure shows the lubrication system of two-stage compression type.

Lubrication cycle

Lubricating oil is pumped in through the manual oil charge valve to oil tank. Oil level can be checked through a sight glass on the oil tank. During the operation, the level should be able to be seen at least from one of the sight glasses. The temperature of the oil tank is indicated on the control panel and its temperature should be below 85°C while operating. What the oil pump does is to transfer the oil from the oil tank

to the system and the adequate pressure difference would be more than 0.8kg/cm² that is maintained by the oil pressure controller. The differential pressure can be seen on the control panel by the pressure gauges between oil tank and oil pump. The oil pump also helps to send the oil to the oil filter.

Isolation valves are installed at both ends of oil filter housing so that no need to drain the whole oil when replacing the filter only. After the oil is sent to the oil cooler it is cooled by the refrigerant flowing from the condenser. The refrigerant cools the oil at the temperature below 74°C. A part of the oil flows through the bearing and gear spray, whereas the rest lubricates the motor shaft bearings and the radial bearings.

The oil temperature in the oil tank is measured by temperature sensor and displayed on control panel. The timer automatically activates the oil pump for 120~180 seconds to maintain a constant pressure first before starting compressor. After the system has been shut down, 300~600 seconds of oil circulation is taken place after the compressor is stopped.

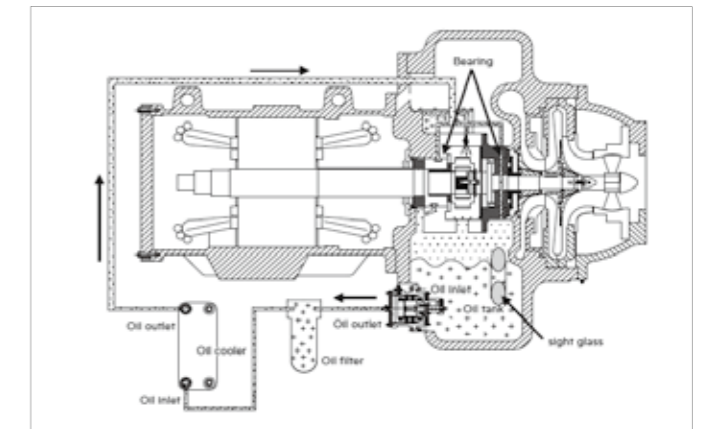

Lubrication cycle

Oil reclaim system

Oil reclaim system provides the system to reclaim the oil from the heat exchanger and let it come back to the oil tank. Normally, it is reclaimed from evaporator, and IGV housing.

Maintenance

Most of the lubrication related deficiencies in rotating parts of the chiller are because of the oil itself. If adequate viscosity, pressure and flow are not obtained, lubricating performance will decrease. Impure substances that are present in the oil also are a cause for the deficiencies. Freon type refrigerant

have chemical attraction with the oil.

The viscosity changes according to the temperature and pressure of oil. We have designed the chiller with these problems into consideration. An oil pump run by hermetic electro motor and a heater controlled by the controlling device are installed in the oil tank to prevent the trouble caused by the refrigerant inflow into the oil, decrease of the viscosity, damage of the pump caused by the cavitation(Vaporizing of water and foaming bubbles as becoming partially low pressurized when water or flow at high speed) and the oil inflow into the refrigerant by forming.

For these reasons the oil tank is maintained at a high temperature. The reason to start the oil pump for certain while before the startup of the chiller, is to prevent the compressor's initial unsteady operation because the left over oil in bearings or in the oil line may contain significant amount of refrigerant flow in during the stoppage. After the chiller has been shut down, oil pump will be operated until the compressor is totally stopped since the shaft will be still rotating due to inertia force. The only action that can be taken to prevent lubrication inferiority caused by blazing of the oil is replacing the oil itself. Thus before chiller operation, make sure that you do the oil replacing adequately.

Safety devices

For the sake of safe operation and the protection of the chiller, safety devices are ready as the next table.

No.	Safety Devices	Installation Location	Measurement Item	Description	Quantity
1	Chilled Water Temperature Low	Chilled water outlet nozzle	Chilled water outlet temperature	Chiller stops operation if the chilled water outlet temperature below 3 °C to prevent freezing of the chilled water. Do not change this set value.	1
2	Evaporator Pressure Low (Temperature Low)	Evaporator shell	Vaporizing pressure (Temp.)	If the pressure inside of evaporator reaches below of the following table, then the chiller stops operation. Standard set value 1.95kg/cm ²	1
3	Condenser Pressure High (Temperature High)	Condenser shell	Condensing pressure (Temperature)	If the pressure inside of condenser reaches above of the following table, then the chiller stops operation. Standard setting value 10.00kg/cm ²	1
4	Motor Temperature High	Motor coil	Motor coil temperature	To prevent the motor of the compressor, temperature sensors were installed on each phase of coil and when the temperature exceeds 90 °C, the chiller stops operation.	3
5	Compressor Temperature High	Compressor outlet	Compressor discharge temperature	If the discharging gas temperature of the compressor exceeds over 70 °C, the chiller stops operation.	1
6	Bearing Temperature High	Thrust bearing	Bearing temperature	Temperature sensor is installed on the thrust bearing that holds the impeller's thrust. Chiller will stop operation if the temperature exceeds 85 °C.	1
7	Oil Differential Pressure Low	Oil tank, oil pump outlet	Differential pressure of supplied and intake oil pressure	If the differential pressure between the oil pressure supplied to the bearing and the oil pressure in the oil tank is below 0.8kg/cm ² , the chiller will stop the operation.	1
8	Oil Temperature High	Oil tank	Oil temperature inside of oil tank	The chiller will stop if the oil temperature in the oil tank is above 74 °C.	1
9	Oil Temperature Low	Oil tank	Oil temperature inside of oil tank	The temperature should be over 30 °C as an initial operating condition to enable the chiller to operate.	1
10	Chilled Water Pump Abnormal	Chilled water header	Chilled water head loss	The chiller will stop if the head loss of the chilled water flow passing through the evaporator tubes decreases so much that the head loss becomes lower than the standard.	1
11	Cooling Water Pump Abnormal	Chilled water header	Cooling water head loss	The chiller will stop if the head loss of the cooling water flow passing through the condenser tubes decreases so much that the head loss becomes lower than the standard.	1
12	Current Limiting Function	Control panel	Current	It is a controlling function of Motor Amps that can be set freely in the range of 40 - 100% to adjust the current load to the motor of compressor.	1
13	Moisture Indicator	Refrigerant supply pipe	Moisture in the refrigerant	The moisture indicator changes the color depending on the amount of moisture in the refrigerant. When there is no moisture it will be green, but if not it will be yellow. It is the time to change into a new filter if you can see the yellow color.	1
14	Relief Valve	Evaporator & condenser shell	Relief valves	To prevent the accident by unexpected fire, and so on which can cause pressure increase in the chiller, the relief valve will be operated and exhaust the refrigerant into the air if the pressure exceeds more than the set value. If the chiller is used in a closed environment, please install a pipe that starts from the relief valve to the outer air.	1
15	Vane Full Close Interlock	Vane motor	Operability of temperature sensors	To minimize the starting current, it is a function to enable the compressor to operate only after full close of the guide vane installed at the inlet of the impeller.	1
16	Temperature Sensor Abnormal	6 locations including chilled water nozzle	Each temperature sensor	It alarms when temperature sensor is not connected or due to the sensor's own flaw.	1
17	Pressure Sensor Abnormal	4 locations including Evaporator shell	Each pressure sensor	It alarms when pressure sensor is not connected or due to the sensor's own flaw.	1
18	Overload relay	Control panel	Current	If overload is imposed on compressor motor or oil pump motor, it stops the motor.	1
19	Hot Gas Bypass Valve	Evaporator shell, Condenser shell	Guide vane / hot gas valve opening	It prevents frequent start ups at low load, and hot gas bypass valve opens proportionally when vane becomes 30% or lower. At this time, hot refrigerant gas from condenser goes to evaporator and makes certain chiller load to prevent surge and to prevent frequent stop / start-up of the chiller.	1

Centrifugal chiller standard summary

Items	Standard	Option
Power Supply	<input type="checkbox"/> 3300V	<input type="checkbox"/> 380V <input type="checkbox"/> 440V <input type="checkbox"/> 6,600V <input type="checkbox"/> 11,000V <input type="checkbox"/> 13,800V <input type="checkbox"/> etc()
Hertz	<input type="checkbox"/> 50Hz	<input type="checkbox"/> 60Hz
Bearing Temperature Sensor	<input type="checkbox"/> Yes(Single type)	<input type="checkbox"/> Dual type
Motor Coil	<input type="checkbox"/> RTD(2-stage)	
Temperature Sensor	<input type="checkbox"/> MTD(1-stage)	<input type="checkbox"/> RTD(1-stage)
Partial load Comp. Code(Closed, AA-DP)	<input type="checkbox"/> I.G.V + HGBP	<input type="checkbox"/> I.G.V+HGBP+2nd I.G.V
Option Comp. Code(Open, E1-G3)	<input type="checkbox"/> I.G.V + HGBP	<input type="checkbox"/> I.G.V+HGBP+Variable Diffuser
Oil Pump	<input type="checkbox"/> 3Ø 380V	<input type="checkbox"/> 3Ø 220V <input type="checkbox"/> 3Ø 400V <input type="checkbox"/> etc()
Communication	<input type="checkbox"/> Modbus	<input type="checkbox"/> BACnet <input type="checkbox"/> TCP/IP(Ethernet) <input type="checkbox"/> Lonwork
Auxiliary Power	<input type="checkbox"/> N/A	<input type="checkbox"/> Yes(UPS:)
International Protection	<input type="checkbox"/> IP4X	<input type="checkbox"/> etc()
Factory Wiring	<input type="checkbox"/> Duct & Flexible	<input type="checkbox"/> Open Wiring <input type="checkbox"/> etc()
Supplied by	<input type="checkbox"/> Factory	<input type="checkbox"/> Supplied by customer
Starter Type	<input type="checkbox"/> Y-Delta(Open)	<input type="checkbox"/> Y-Delta(Closed) <input type="checkbox"/> Reactor <input type="checkbox"/> Kondorfer <input type="checkbox"/> Direct <input type="checkbox"/> Soft starter <input type="checkbox"/> Inverter(VSD)
Mounted Type	<input type="checkbox"/> Stand alone	<input type="checkbox"/> Unit mounted
Circuit Low V(380V/440V)	<input type="checkbox"/> MCCB	<input type="checkbox"/> ACB(65kA) <input type="checkbox"/> etc()
Breaker Type High V(3,300V-6,600V)	<input type="checkbox"/> FDS	<input type="checkbox"/> VCB(Fixed type) <input type="checkbox"/> VCB(Draw out type)
	<input type="checkbox"/> 8kA	<input type="checkbox"/> 12.5kA <input type="checkbox"/> 25kA <input type="checkbox"/> 31.5kA
Power Access	<input type="checkbox"/> From the top	<input type="checkbox"/> From the bottom <input type="checkbox"/> etc()
International Protection	<input type="checkbox"/> IP4X	<input type="checkbox"/> etc()
Power Factor Correction Capacitor	<input type="checkbox"/> N/A	<input type="checkbox"/> Yes
Integrating Watt-meter	<input type="checkbox"/> N/A	<input type="checkbox"/> Yes <input type="checkbox"/> etc()
Ground Fault Protection	<input type="checkbox"/> N/A	<input type="checkbox"/> ZCT(NGS) <input type="checkbox"/> ZCT(GS)+OCGR <input type="checkbox"/> GPT,SGR,ZCT(NGS)
Momentary Power Loss Compensation	<input type="checkbox"/> N/A	<input type="checkbox"/> Yes
Waterbox Type	<input type="checkbox"/> NIH(Rectangle)	<input type="checkbox"/> NIH(Circle) <input type="checkbox"/> Marine <input type="checkbox"/> Marine + hinged
Waterbox Pressure	<input type="checkbox"/> 150 psig(10kg/cm ²)	<input type="checkbox"/> 230 psig(16kg/cm ²) <input type="checkbox"/> 300 psig(20kg/cm ²)
Waterbox Coating	<input type="checkbox"/> Standard	<input type="checkbox"/> Epoxy Coating <input type="checkbox"/> Ceramic Coating
Nozzle Arrangement(Inlet)	<input type="checkbox"/> Motor End	<input type="checkbox"/> Compressor End
Nozzle Arrangement(Outlet)	<input type="checkbox"/> Motor End	<input type="checkbox"/> Compressor End
Nozzle Type	<input type="checkbox"/> ANSI-Flange	<input type="checkbox"/> ANSI-Victaulic(AGS) <input type="checkbox"/> ANSI-Victaulic(OGS)
Flow Proof Type(Ref.)	<input type="checkbox"/> Relief V/V(Single)	<input type="checkbox"/> Relief V/V(Dual)
Waterbox Type	<input type="checkbox"/> NIH(Rectangle)	<input type="checkbox"/> NIH(Circle) <input type="checkbox"/> Marine <input type="checkbox"/> Marine + hinged
Waterbox Pressure	<input type="checkbox"/> 150 psig(10kg/cm ²)	<input type="checkbox"/> 230 psig(16kg/cm ²) <input type="checkbox"/> 300 psig(20kg/cm ²)
Waterbox Coating	<input type="checkbox"/> Standard	<input type="checkbox"/> Epoxy Coating <input type="checkbox"/> Ceramic Coating
Nozzle Arrangement(Inlet)	<input type="checkbox"/> Motor End	<input type="checkbox"/> Compressor End
Nozzle Arrangement(Outlet)	<input type="checkbox"/> Motor End	<input type="checkbox"/> Compressor End
Nozzle Type	<input type="checkbox"/> ANSI-Flange	<input type="checkbox"/> ANSI-Victaulic(AGS) <input type="checkbox"/> ANSI-Victaulic(OGS)
Flow Proof Type(Water)	<input type="checkbox"/> N/A	<input type="checkbox"/> DP switch
Flow Proof Type(Ref.)	<input type="checkbox"/> Relief V/V(Single)	<input type="checkbox"/> Relief V/V(Dual)
Refrigerant(R134a)	<input type="checkbox"/> Separated Shipping	<input type="checkbox"/> Customer Supplied <input type="checkbox"/> Factory Charged
Oil Charge	<input type="checkbox"/> Separated Shipping	<input type="checkbox"/> Customer Supplied <input type="checkbox"/> Factory Charged
Packing	<input type="checkbox"/> Shrink Film	<input type="checkbox"/> Wooden Packing
Insulation	<input type="checkbox"/> No	<input type="checkbox"/> Yes
Sound Attenuator	<input type="checkbox"/> N/A	<input type="checkbox"/> Discharge Only <input type="checkbox"/> Condenser + Discharge
Isolation	<input type="checkbox"/> Neoprene PAD	<input type="checkbox"/> Spring 1 inch <input type="checkbox"/> Spring 2inch <input type="checkbox"/> Spring Rubber Pad
Anchor Bolt for Foundation	<input type="checkbox"/> N/A	<input type="checkbox"/> Yes(Set-Anchor) <input type="checkbox"/> Yes(L-TYPE(M20*250L))
Automatic Expansion V/V(2-stage)	<input type="checkbox"/> Standard	<input type="checkbox"/> Auto Expansion V/V 2EA, Level Sensor 2EA
Counter Pipe Flange	<input type="checkbox"/> N/A	<input type="checkbox"/> Yes
Certification	<input type="checkbox"/> Standard(KGS)	<input type="checkbox"/> ASME VII Only <input type="checkbox"/> CE(PED) <input type="checkbox"/> PED <input type="checkbox"/> (C)UL(ETL)
Factory Performance Test & Process inspection	<input type="checkbox"/> N/A	<input type="checkbox"/> Report Only <input type="checkbox"/> Customer Witness <input type="checkbox"/> Process Inspection
Startup Commissioning	<input type="checkbox"/> N/A	<input type="checkbox"/> Supervising Only
Partial Load Test	<input type="checkbox"/> N/A	<input type="checkbox"/> 75% <input type="checkbox"/> 50% <input type="checkbox"/> 25%
Operating Training	<input type="checkbox"/> N/A	<input type="checkbox"/> Yes
Warranty-Compressor	<input type="checkbox"/> 1 yr	<input type="checkbox"/> etc()
Warranty-Ass'y	<input type="checkbox"/> 1 yr	<input type="checkbox"/> etc()
Labor Warranty	<input type="checkbox"/> N/A	<input type="checkbox"/> etc()

- 1) Factory Wiring : Duct & Flexible
- 2) Color : Dawn Gray
 - Starter Panel : Warm Gray(Unit Mounted), RAL7035(Stand Alone)
 - Control Panel : Warm Gray
- 3) Controller : MICOM / Display : 10.2 inch touch screen
- 4) Standard provide Internal Inspection Lamp and Emergency stop switch
- 5) Part load option : Hot Gas By Pass
- 6) Standard provide VCS(Fixed Type) at high voltage
- 7) Flow proof type : DP Switch(Evaporator)

Standard Specification

Machine outline

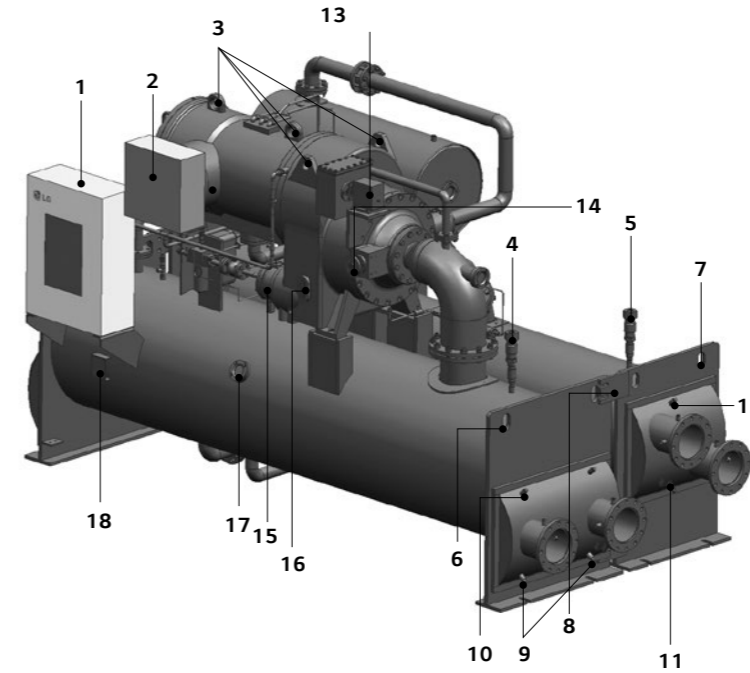

Front view

1. Control panel
2. Motor terminal box
3. Lifting hole for compressor overhaul
4. Evaporator safety valve
5. Condenser safety valve
6. Lifting hole for evaporator
7. Lifting hole for condenser
8. Assembly bracket
9. Drain for chilled water
10. Air vent for chilled water
11. Drain for cooling water
12. Air vent for cooling water
13. Actuator for variable diffuser
14. Actuator for vane motor
15. Oil pump
16. Sight glass for oil tank
17. Sight glass for evaporator
18. Name plate of evaporator

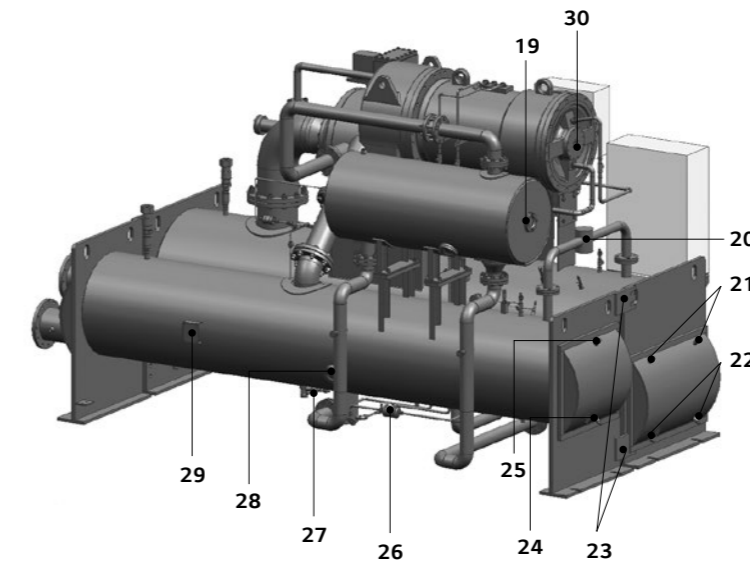

Rear view

19. Sight glass for economizer
20. Hot-gas bypass
21. Air vent for chilled water
22. Drain for chilled water
23. Assembly bracket
24. Drain for cooling water
25. Air vent for cooling water
26. Filter drier
27. Service valve
28. Sight glass for condenser
29. Name plate of condenser
30. Sight glass for checking the motor rotation direction

Notes: 1. This image may not be same with real.
2. To improve the performance, some specification can be changed without notice.

2-stage model(12°C → 7°C)

Model		Units	RCWFHAL	RCWFHAM	RCWFHAN	RCWFHAP	RCWFHBM	RCWFHBN
Standard Condition	Cooling Capacity	usRT	200	250	275	300	400	450
		kW	703	879	967	1,055	1,407	1,582
	Shipping Weight	kg	5,250	5,350	5,450	5,500	6,900	7,000
	Operating Weight	kg	5,950	6,100	6,250	6,300	8,000	8,200
Unit Data High Ambient	Type		2-stage Centrifugal Compressor					
	No	EA	1					
	Power Supply		3 Ph / 3,300 V / 50(60) Hz					
	Oil Pump		3 Ph / 220 V, 380 V, 440 V / 60 Hz					
Evaporator	Design Pressure	MPa	1.0	1.0	1.0	1.0	1.0	1.0
	Nozzle Connection Size	A	150	150	200	200	200	200
	Rated Flow Rate	m ² /hr	121	151	166	181	242	272
	Fouling Factor	m ² °C/kW	0.018	0.018	0.018	0.018	0.018	0.018
	Pressure Drop	mAq	4.7	4.9	4.0	4.7	4.7	4.9
	Pass	EA	2	2	2	2	2	2
Condenser	Design Pressure	MPa	1.0	1.0	1.0	1.0	1.0	1.0
	Nozzle Connection Size	A	150	150	200	200	200	200
	Rated Flow Rate	m ² /hr	144	180	197	215	284	319
	Fouling Factor	m ² °C/kW	0.044	0.044	0.044	0.044	0.044	0.044
	Pressure Drop	mAq	6.6	6.8	5.6	6.5	6.7	6.6
	Pass	EA	2	2	2	2	2	2
Dimension	Length	mm	3,480	3,480	3,480	3,480	3,500	3,500
	Width	mm	1,940	1,940	1,940	1,940	2,130	2,130
	Height	mm	2,030	2,030	2,030	2,030	2,220	2,220

Model		Units	RCWFHBP	RCWFHCM	RCWFHCN	RCWFHCP	RCWFHDM	RCWFHDN
Standard Condition	Cooling Capacity	usRT	500	550	600	700	800	900
		kW	1,758	1,934	2,110	2,461	2,813	3,165
	Shipping Weight	kg	7,100	7,900	8,800	8,950	10,350	11,900
	Operating Weight	kg	8,350	9,200	10,300	10,600	12,300	14,300
Unit Data High Ambient	Type		2-stage Centrifugal Compressor					
	No	EA	1					
	Power Supply		3 Ph / 3,300 V / 50(60) Hz					
	Oil Pump		3 Ph / 220 V, 380 V, 440 V / 60 Hz					
Evaporator	Design Pressure	MPa	1.0	1.0	1.0	1.0	1.0	1.0
	Nozzle Connection Size	A	200	200	200	250	250	300
	Rated Flow Rate	m ² /hr	302	333	363	423	484	544
	Fouling Factor	m ² °C/kW	0.018	0.018	0.018	0.018	0.018	0.018
	Pressure Drop	mAq	5.0	5.1	5.3	5.6	8.3	8.7
	Pass	EA	2	2	2	2	2	2
Condenser	Design Pressure	MPa	1.0	1.0	1.0	1.0	1.0	1.0
	Nozzle Connection Size	A	200	200	200	250	250	300
	Rated Flow Rate	m ² /hr	354	390	424	494	564	633
	Fouling Factor	m ² °C/kW	0.044	0.044	0.044	0.044	0.044	0.044
	Pressure Drop	mAq	7.0	7.0	7.1	6.6	10.7	9.3
	Pass	EA	2	2	2	2	2	2
Dimension	Length	mm	3,500	3,540	3,540	3,540	4,150	4,150
	Width	mm	2,130	2,270	2,270	2,270	2,500	2,750
	Height	mm	2,220	2,410	2,480	2,480	2,730	2,810

Precautions

- LG centrifugal chillers are a combination of compressors, condensers, and evaporators, enabling various model deployment and providing other specifications. In this case, please contact LG Electronics.
- To improve the performance, some specification can be changed without notice.
- Y-Δ, Primary Reactor, Kondorfer, and Inverter are available for the starter.
- 1 usRT = 3,024 kcal / h
- If you want specifications for heat pumps and special condition, please contact LG Electronics.
- Cooling inlet / outlet temperature : 32 °C / 37 °C

2-stage model(12°C → 7°C)

Model		Units	RCWFHDP	RCWFHEM	RCWFHEN	RCWFHEP	RCWFHF1
Standard Condition	Cooling Capacity	usRT	1,000	1,100	1,300	1,500	1,600
		kW	3,516	3,868	4,571	5,274	5,626
	Shipping Weight	kg	12,200	14,300	17,650	19,100	21,700
	Operating Weight	kg	14,700	16,900	21,050	23,150	26,350
Unit Data High Ambient	Type		2-stage Centrifugal Compressor				
	No	EA	1				
	Power Supply		3 Ph / 3,300 V / 50(60) Hz				
	Oil Pump		3 Ph / 220 V, 380 V, 440 V / 60 Hz				
Evaporator	Design Pressure	MPa	1.0	1.0	1.0	1.0	1.0
	Nozzle Connection Size	A	300	300	300	350	350
	Rated Flow Rate	m ² /hr	605	665	786	907	968
	Fouling Factor	m ² °C/kW	0.018	0.018	0.018	0.018	0.018
	Pressure Drop	mAq	7.4	8.8	10.4	10.3	9.0
	Pass	EA	2	2	2	2	2
Condenser	Design Pressure	MPa	1.0	1.0	1.0	1.0	1.0
	Nozzle Connection Size	A	350	350	350	400	400
	Rated Flow Rate	m ² /hr	702	775	912	1,051	1,128
	Fouling Factor	m ² °C/kW	0.044	0.044	0.044	0.044	0.044
	Pressure Drop	mAq	10.0	10.2	12.6	12.4	11.4
	Pass	EA	2	2	2	2	2
Dimension	Length	mm	4,150	4,350	4,700	4,700	4,700
	Width	mm	2,750	2,680	3,060	3,190	3,660
	Height	mm	2,810	3,020	3,100	3,280	3,440

Model		Units	RCWFHF2	RCWFHF3	RCWFHG1	RCWFHG2	RCWFHG3
Standard Condition	Cooling Capacity	usRT	1,800	2,000	2,150	2,630	3,000
		kW	6,329	7,033	7,560	9,248	10,549
	Shipping Weight	kg	22,300	24,200	27,200	29,200	31,000
	Operating Weight	kg	27,300	29,800	33,200	36,250	38,300
Unit Data High Ambient	Type		2-stage Centrifugal Compressor				
	No	EA	1				
	Power Supply		3 Ph / 3,300 V / 50(60) Hz				
	Oil Pump		3 Ph / 220 V, 380 V, 440 V / 60 Hz				
Evaporator	Design Pressure	MPa	1.0	1.0	1.0	1.0	1.0
	Nozzle Connection Size	A	400	400	450	450	500
	Rated Flow Rate	m ² /hr	1,089	1,210	1,300	1,591	1,814
	Fouling Factor	m ² °C/kW	0.018	0.018	0.018	0.018	0.018
	Pressure Drop	mAq	13.8	3.2	3.4	6.0	6.3
	Pass	EA	2	1	1	1	1
Condenser	Design Pressure	MPa	1.0	1.0	1.0	1.0	1.0
	Nozzle Connection Size	A	400	450	450	500	500
	Rated Flow Rate	m ² /hr	1,267	1,403	1,516	1,848	2,104
	Fouling Factor	m ² °C/kW	0.044	0.044	0.044	0.044	0.044
	Pressure Drop	mAq	3.1	3.4	4.7	7.2	8.2
	Pass	EA	1	1	1	1	1
Dimension	Length	mm	5,390	5,910	6,470	7,470	7,470
	Width	mm	3,660	3,660	3,660	3,660	3,660
	Height	mm	3,440	3,440	3,920	3,920	3,920

Precautions

- LG centrifugal chillers are a combination of compressors, condensers, and evaporators, enabling various model deployment and providing other specifications. In this case, please contact LG Electronics.
- To improve the performance, some specification can be changed without notice.
- Y-Δ, Primary Reactor, Kondorfer, and Inverter are available for the starter.
- 1 usRT = 3,024 kcal / h
- If you want specifications for heat pumps and special condition, please contact LG Electronics.
- Cooling inlet / outlet temperature : 32 °C / 37 °C

2-stage model(10°C → 5°C)

Model		Units	RCWFHAL	RCWFHAM	RCWFHAN	RCWFHAP	RCWFHBM	RCWFHBN
Standard Condition	Cooling Capacity	usRT	200	250	275	300	400	450
		kW	703	879	967	1,055	1,407	1,582
	Shipping Weight	kg	5,250	5,350	5,450	5,500	6,900	7,000
	Operating Weight	kg	5,950	6,100	6,250	6,300	8,000	8,200
Unit Data High Ambient	Type		2-stage Centrifugal Compressor					
	No	EA	1					
	Power Supply		3 Ph / 3,300 V / 50(60) Hz					
	Oil Pump		3 Ph / 220 V, 380 V, 440 V / 60 Hz					
Evaporator	Design Pressure	MPa	1.0	1.0	1.0	1.0	1.0	1.0
	Nozzle Connection Size	A	150	150	200	200	200	200
	Rated Flow Rate	m ² /hr	121	151	166	181	242	272
	Fouling Factor	m ² °C/kW	0.018	0.018	0.018	0.018	0.018	0.018
	Pressure Drop	mAq	4.8	4.9	4.1	4.8	4.8	5.0
	Pass	EA	2	2	2	2	2	2
Condenser	Design Pressure	MPa	1.0	1.0	1.0	1.0	1.0	1.0
	Nozzle Connection Size	A	150	150	200	200	200	200
	Rated Flow Rate	m ² /hr	145	181	199	216	288	324
	Fouling Factor	m ² °C/kW	0.044	0.044	0.044	0.044	0.044	0.044
	Pressure Drop	mAq	6.8	6.9	5.7	6.6	6.9	6.8
	Pass	EA	2	2	2	2	2	2
Dimension	Length	mm	3,480	3,480	3,480	3,480	3,500	3,500
	Width	mm	1,940	1,940	1,940	1,940	2,130	2,130
	Height	mm	2,030	2,030	2,030	2,030	2,220	2,220

Model		Units	RCWFHBP	RCWFHCM	RCWFHCN	RCWFHCP	RCWFHDM	RCWFHDN
Standard Condition	Cooling Capacity	usRT	500	550	600	700	800	900
		kW	1,758	1,934	2,110	2,461	2,813	3,165
	Shipping Weight	kg	7,100	7,900	8,800	8,950	10,350	11,900
	Operating Weight	kg	8,350	9,200	10,300	10,600	12,300	14,300
Unit Data High Ambient	Type		2-stage Centrifugal Compressor					
	No	EA	1					
	Power Supply		3 Ph / 3,300 V / 50(60) Hz					
	Oil Pump		3 Ph / 220 V, 380 V, 440 V / 60 Hz					
Evaporator	Design Pressure	MPa	1.0	1.0	1.0	1.0	1.0	1.0
	Nozzle Connection Size	A	200	200	200	250	250	300
	Rated Flow Rate	m ² /hr	302	333	363	423	484	544
	Fouling Factor	m ² °C/kW	0.018	0.018	0.018	0.018	0.018	0.018
	Pressure Drop	mAq	5.1	5.2	5.3	5.7	8.4	8.8
	Pass	EA	2	2	2	2	2	2
Condenser	Design Pressure	MPa	1.0	1.0	1.0	1.0	1.0	1.0
	Nozzle Connection Size	A	200	200	200	250	250	300
	Rated Flow Rate	m ² /hr	358	395	430	500	573	641
	Fouling Factor	m ² °C/kW	0.044	0.044	0.044	0.044	0.044	0.044
	Pressure Drop	mAq	7.2	7.1	7.3	6.7	11.0	9.5
	Pass	EA	2	2	2	2	2	2
Dimension	Length	mm	3,500	3,540	3,540	3,540	4,150	4,150
	Width	mm	2,130	2,270	2,270	2,270	2,500	2,750
	Height	mm	2,220	2,410	2,480	2,480	2,730	2,810

Precautions

- LG centrifugal chillers are a combination of compressors, condensers, and evaporators, enabling various model deployment and providing other specifications. In this case, please contact LG Electronics.
- To improve the performance, some specification can be changed without notice.
- Y-Δ, Primary Reactor, Kondorfer, and Inverter are available for the starter.
- 1 usRT = 3,024 kcal / h
- If you want specifications for heat pumps and special condition, please contact LG Electronics.
- Cooling inlet / outlet temperature : 32 °C / 37 °C

2-stage model(10°C → 5°C)

Model		Units	RCWFHDP	RCWFHEM	RCWFHEN	RCWFHEP	RCWFHF1
Standard Condition	Cooling Capacity	usRT	1,000	1,100	1,300	1,500	1,600
		kW	3,516	3,868	4,571	5,274	5,626
	Shipping Weight	kg	12,200	14,300	17,650	19,100	21,700
	Operating Weight	kg	14,700	16,900	21,050	23,150	26,350
Unit Data High Ambient	Type		2-stage Centrifugal Compressor				
	No	EA	1				
	Power Supply		3 Ph / 3,300 V / 50(60) Hz				
	Oil Pump		3 Ph / 220 V, 380 V, 440 V / 60 Hz				
Evaporator	Design Pressure	MPa	1.0	1.0	1.0	1.0	1.0
	Nozzle Connection Size	A	300	300	300	350	350
	Rated Flow Rate	m ² /hr	605	665	786	907	968
	Fouling Factor	m ² °C/kW	0.018	0.018	0.018	0.018	0.018
	Pressure Drop	mAq	7.5	8.9	10.6	10.4	9.1
	Pass	EA	2	2	2	2	2
Condenser	Design Pressure	MPa	1.0	1.0	1.0	1.0	1.0
	Nozzle Connection Size	A	350	350	350	400	400
	Rated Flow Rate	m ² /hr	713	785	922	1,063	1,142
	Fouling Factor	m ² °C/kW	0.044	0.044	0.044	0.044	0.044
	Pressure Drop	mAq	10.3	10.4	12.8	12.7	11.6
	Pass	EA	2	2	2	2	2
Dimension	Length	mm	4,150	4,350	4,700	4,700	4,700
	Width	mm	2,750	2,680	3,060	3,190	3,660
	Height	mm	2,810	3,020	3,100	3,280	3,440

Model		Units	RCWFHF2	RCWFHF3	RCWFHG1	RCWFHG2	RCWFHG3
Standard Condition	Cooling Capacity	usRT	1,800	2,000	2,150	2,630	3,000
		kW	6,329	7,033	7,560	9,248	10,549
	Shipping Weight	kg	22,300	24,200	27,200	29,200	31,000
	Operating Weight	kg	27,300	29,800	33,200	36,250	38,300
Unit Data High Ambient	Type		2-stage Centrifugal Compressor				
	No	EA	1				
	Power Supply		3 Ph / 3 300 V / 50(60) Hz				
	Oil Pump		3 Ph / 220 V, 380 V, 440 V / 60 Hz				
Evaporator	Design Pressure	MPa	1.0	1.0	1.0	1.0	1.0
	Nozzle Connection Size	A	400	400	450	450	500
	Rated Flow Rate	m ² /hr	1,089	1,210	1,300	1,591	1,814
	Fouling Factor	m ² °C/kW	0.018	0.018	0.018	0.018	0.018
	Pressure Drop	mAq	14.0	3.3	3.7	6.1	6.4
	Pass	EA	2	1	1	1	1
Condenser	Design Pressure	MPa	1.0	1.0	1.0	1.0	1.0
	Nozzle Connection Size	A	400	450	450	500	500
	Rated Flow Rate	m ² /hr	1,283	1,422	1,530	1,866	2,125
	Fouling Factor	m ² °C/kW	0.044	0.044	0.044	0.044	0.044
	Pressure Drop	mAq	3.2	3.4	5.1	7.3	8.3
	Pass	EA	1	1	1	1	1
Dimension	Length	mm	5,390	5,910	6,470	7,470	7,470
	Width	mm	3,660	3,660	3,660	3,660	3,660
	Height	mm	3,440	3,440	3,920	3,920	3,920

Precautions

- LG centrifugal chillers are a combination of compressors, condensers, and evaporators, enabling various model deployment and providing other specifications. In this case, please contact LG Electronics.
- To improve the performance, some specification can be changed without notice.
- Y-Δ, Primary Reactor, Kondorfer, and Inverter are available for the starter.
- 1 usRT = 3,024 kcal / h
- If you want specifications for heat pumps and special condition, please contact LG Electronics.
- Cooling inlet / outlet temperature : 32 °C / 37 °C

2-Stage Inverter Model(12°C → 7°C)

Model		Units	RCWFHAL	RCWFHAM	RCWFHAN	RCWFHAP	RCWFHBM	RCWFHBN	RCWFHBP
Standard Condition	Cooling Capacity	usRT	200	250	275	300	400	450	500
		kW	703	879	967	1,055	1,407	1,582	1,758
	Shipping Weight	kg	5,550	5,650	5,900	5,950	7,350	7,450	7,550
	Operating Weight	kg	6,250	6,400	6,650	6,700	8,500	8,650	8,800
Unit Data High Ambient	Type	2-stage Centrifugal Compressor							
	No	EA	1						
	Power Supply	3 Ph / 380 V - 440 V							
	Oil Pump	3 Ph / 220 V, 380 V, 440 V / 60 Hz							
Evaporator	Design Pressure	MPa	1.0	1.0	1.0	1.0	1.0	1.0	1.0
	Nozzle Connection Size	A	150	150	200	200	200	200	200
	Rated Flow Rate	m ² /hr	121	151	166	181	242	272	302
	Fouling Factor	m ² °C/kW	0.018	0.018	0.018	0.018	0.018	0.018	0.018
	Pressure Drop	mAq	4.7	4.9	4.0	4.7	4.7	4.9	5.0
	Pass	EA	2	2	2	2	2	2	2
Condenser	Design Pressure	MPa	1.0	1.0	1.0	1.0	1.0	1.0	1.0
	Nozzle Connection Size	A	150	150	200	200	200	200	200
	Rated Flow Rate	m ² /hr	145	180	197	215	286	321	356
	Fouling Factor	m ² °C/kW	0.044	0.044	0.044	0.044	0.044	0.044	0.044
	Pressure Drop	mAq	6.7	6.8	5.6	6.5	6.8	6.7	7.1
	Pass	EA	2	2	2	2	2	2	2
Dimension	Length	mm	3,480	3,480	3,480	3,480	3,500	3,500	3,500
	Width	mm	2,780	2,780	2,780	2,780	2,900	2,900	2,900
	Height	mm	2,030	2,030	2,030	2,030	2,220	2,220	2,220

Model		Units	RCWFHCM	RCWFHCN	RCWFHCP	RCWFHDM	RCWFHDN	RCWFHDP
Standard Condition	Cooling Capacity	usRT	550	600	700	800	900	1,000
		kW	1,934	2,110	2,461	2,813	3,165	3,516
	Shipping Weight	kg	8,500	9,400	9,600	11,000	12,550	12,850
	Operating Weight	kg	9,800	10,950	11,200	12,950	14,950	15,350
Unit Data High Ambient	Type	2-stage Centrifugal Compressor						
	No	EA	1					
	Power Supply	3 Ph / 380 V - 440 V						
	Oil Pump	3 Ph / 220 V, 380 V, 440 V / 60 Hz						
Evaporator	Design Pressure	MPa	1.0	1.0	1.0	1.0	1.0	1.0
	Nozzle Connection Size	A	200	200	250	250	300	300
	Rated Flow Rate	m ² /hr	333	363	423	484	544	605
	Fouling Factor	m ² °C/kW	0.018	0.018	0.018	0.018	0.018	0.018
	Pressure Drop	mAq	5.1	5.3	5.6	8.3	8.7	7.4
	Pass	EA	2	2	2	2	2	2
Condenser	Design Pressure	MPa	1.0	1.0	1.0	1.0	1.0	1.0
	Nozzle Connection Size	A	200	200	250	250	300	350
	Rated Flow Rate	m ² /hr	393	428	497	571	640	710
	Fouling Factor	m ² °C/kW	0.044	0.044	0.044	0.044	0.044	0.044
	Pressure Drop	mAq	7.1	7.2	6.7	10.9	9.4	10.2
	Pass	EA	2	2	2	2	2	2
Dimension	Length	mm	3,540	3,540	3,540	4,150	4,150	4,150
	Width	mm	2,900	2,950	2,950	3,150	3,150	3,150
	Height	mm	2,410	2,480	2,480	2,730	2,810	2,810

Precautions

- LG centrifugal chillers are a combination of compressors, condensers, and evaporators, enabling various model deployment and providing other specifications. In this case, please contact LG Electronics.
- To improve the performance, some specification can be changed without notice.
- Starter panel is supplied as unit-mounted type.
- 1 usRT = 3,024 kcal / h
- It is available at high voltage, please contact LG Electronics if you want.
- Cooling inlet / outlet temperature : 32 °C / 37 °C

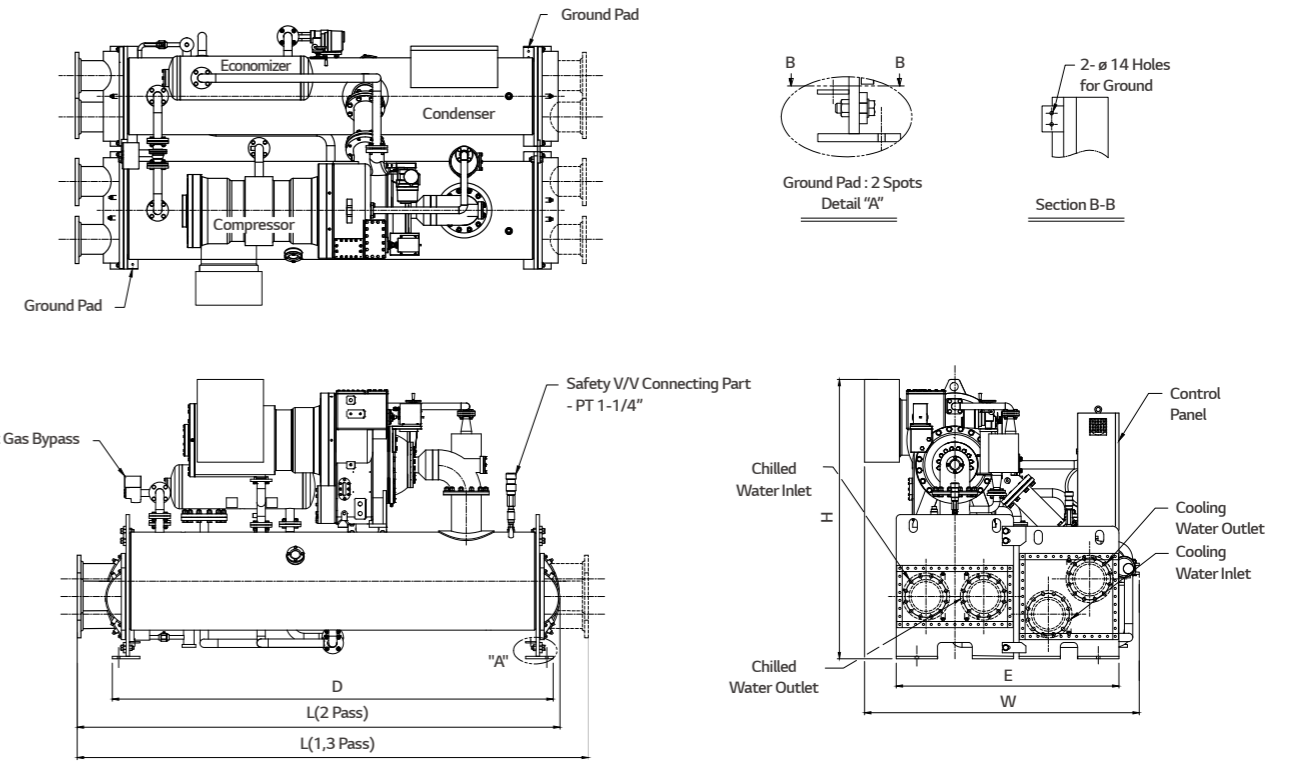

[Unit : mm]

Model		Outline Dimension				Base Dimension		Water Flow Pass(A)	
		L(Length)		W(Width)	H(Height)	D	E	Evaporator	Condenser
		2 Pass	1,3 Pass					2 Pass	2 Pass
RCWFH	AL-AM	3,480	3,720	1,940	2,030	3,200	1,616	150	150
RCWFH	AN-AP	3,480	3,720	1,940	2,030	3,200	1,616	200	200
RCWFH	BM-BP	3,500	3,720	2,130	2,220	3,200	1,900	200	200
RCWFH	CM	3,540	3,720	2,270	2,410	3,200	1,900	200	200
RCWFH	CN	3,540	3,720	2,270	2,480	3,200	2,067	200	200
RCWFH	CP	3,540	3,720	2,270	2,480	3,200	2,067	250	250
RCWFH	DM	4,150	4,350	2,500	2,730	3,850	2,067	250	250
RCWFH	DN	4,150	4,350	2,750	2,810	3,850	2,392	300	300
RCWFH	DP	4,150	4,350	2,750	2,810	3,850	2,392	300	350
RCWFH	EM	4,350	4,570	2,680	3,020	3,850	2,392	300	350
RCWFH	EN	4,700	4,920	3,060	3,100	4,200	2,818	300	350
RCWFH	EP	4,700	4,920	3,190	3,280	4,200	2,928	350	400
RCWFH	F1	4,700	4,920	3,660	3,440	4,200	3,018	350	400
RCWFH	F2	5,180	5,390	3,660	3,440	4,680	3,018	400	400
RCWFH	F3	5,700	5,910	3,660	3,440	5,200	3,018	400	450
RCWFH	G1	6,340	6,470	3,660	3,920	5,700	3,018	450	450
RCWFH	G2	7,340	7,470	3,660	3,920	6,700	3,018	450	500
RCWFH	G3	7,340	7,470	3,660	3,920	6,700	3,018	500	500

Precautions

1. The height is measured from the bottom of the heat exchanger bed. This value does not include the height of the foundation and the vibration-absorbing pedestal.
2. All of the chilled water and cooling water connection flanges are of ANSI 150lb.
3. The water pipe facility shall be designed to preventing external force to the chiller.
4. The minimum spaces shall be provided around the chiller as follow :
 - Length direction of the chiller : 1,500mm(AL - EM), 2,000mm(EN - G3)
 - The left and the right side space for Tube replacement : 3,000mm(AL - CP), 3,700mm(DM - EM), 4,100mm(EN - EP), 5,000mm(F1 - G3)
 - Control panel : 1,500mm(AL - CP), 2,000mm(DM - G3)
 - Direction of height : 1,000mm(AL - CP), 1,500mm(DM - G3)
5. To improve the performance, some specification can be changed without notice.

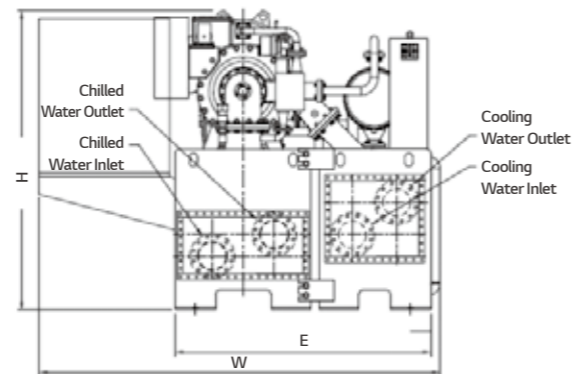
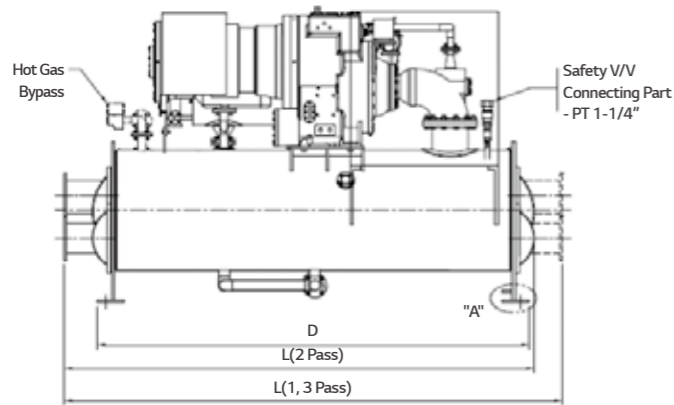
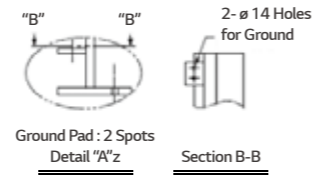
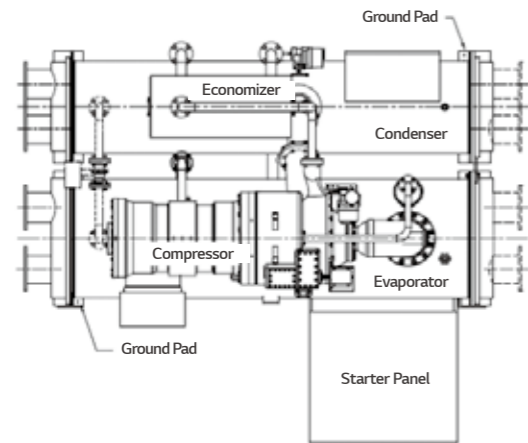

[Unit : mm]

Model	Outline Dimension				Base Dimension		Water Flow Pass(A)		
	L(Length)		W(Width)	H(Height)	D	E	Evaporator	Condenser	
	2 Pass	1,3 Pass							
RCWFH	AL - AM	3,480	3,720	2,780	2,030	3,200	1,616	150	150
RCWFH	AN - AP	3,480	3,720	2,780	2,030	3,200	1,616	200	200
RCWFH	BM - BP	3,500	3,720	2,950	2,230	3,200	1,900	200	200
RCWFH	CM	3,540	3,720	2,950	2,410	3,200	1,900	200	200
RCWFH	CN	3,540	3,720	2,950	2,480	3,200	2,067	200	200
RCWFH	CP	3,540	3,720	2,950	2,480	3,200	2,067	250	250
RCWFH	DM	4,150	4,350	3,150	2,730	3,850	2,067	250	250
RCWFH	DN	4,150	4,350	3,400	2,810	3,850	2,392	300	300
RCWFH	DP	4,150	4,350	3,400	2,810	3,850	2,392	300	300

Precautions

- The height is measured from the bottom of the heat exchanger bed. This value does not include the height of the foundation and the vibration-absorbing pedestal.
- All of the chilled water and cooling water connection flanges are of ANSI 150lb.
- The water pipe facility shall be designed to preventing external force to the chiller.
- The minimum spaces shall be provided around the chiller as follow :
 - Length direction of the chiller : 1,500mm(AL - EM), 2,000mm(EN - G3)
 - The left and the right side space for Tube replacement : 3,000mm(AL - CP), 3,700mm(DM - EM), 4,100mm(EN - EP), 5,000mm(F1 - G3)
 - Control panel : 1,500mm(AL - CP), 2,000mm(DM - G3)
 - Direction of height : 1,000mm(AL - CP), 1,500mm(DM - G3)
- To improve the performance, some specification can be changed without notice.

Vibration isolation & Foundation

Typical isolation

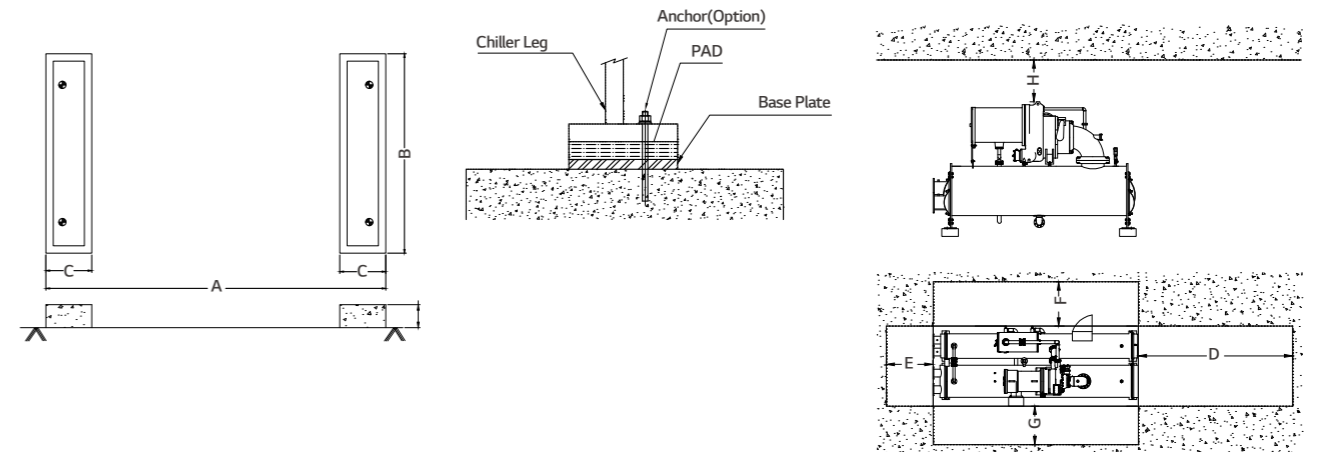

Note:
 D : Minimum needs space of exchanging tube
 F : Minimum needs space of control panel side
 H : Minimum needs space of top

[Unit : mm]

Model		A	B	C	D	E	F	G	H
RCWFH	AL - AM	3,400	1,750	400	3,100	2,000	1,500	1,500	1,500
RCWFH	AN - AP	3,400	1,750	400	3,100	2,000	1,500	1,500	1,500
RCWFH	BM - BP	3,400	2,000	400	3,100	2,000	1,500	1,500	1,500
RCWFH	CM	3,400	2,000	400	3,100	2,000	1,500	1,500	1,500
RCWFH	CN	3,400	2,200	400	3,100	2,000	1,500	1,500	1,500
RCWFH	CP	3,400	2,200	400	3,100	2,000	1,500	1,500	1,500
RCWFH	DM	4,050	2,200	400	3,800	2,000	1,500	1,500	1,500
RCWFH	DN	4,050	2,500	400	3,800	2,000	1,500	1,500	1,500
RCWFH	DP	4,050	2,500	400	3,800	2,000	1,500	1,500	1,500
RCWFH	EM	4,050	2,500	400	3,800	2,000	1,500	1,500	1,500
RCWFH	EN	4,400	2,950	400	4,100	2,000	1,500	1,500	1,500
RCWFH	EP	4,400	3,050	400	4,100	2,000	1,500	1,500	1,500
RCWFH	F1	4,400	3,150	400	4,100	2,000	1,500	1,500	1,500
RCWFH	F2	4,880	3,150	400	4,600	2,000	1,500	1,500	1,500
RCWFH	F3	5,400	3,150	400	5,100	2,000	1,500	1,500	1,500
RCWFH	G1	5,900	3,150	400	5,600	2,000	1,500	1,500	1,500
RCWFH	G2	6,900	3,150	400	6,600	2,000	1,500	1,500	1,500
RCWFH	G3	6,900	3,150	400	6,600	2,000	1,500	1,500	1,500

Precautions

- Using the installation equipment, level the chiller and attach the vibration proof pad to the chiller plate.
- The operating weight shall be equally distributed on the 4 supports.
- The foundation height shall be approximately 150-200mm to work piping and drainage easily.

Note:

- This drawing is the foundation drawing of the standard model. It is possible to differ depend on site conditions.

Chilled / cooling water piping

- As a standard, 10kg/cm² of flange is adopted for evaporator and condenser nozzles.
- The inlet nozzle is located on the lower side and the outlet is positioned on the upper side as a standard.
- All piping should be supported independently in order not to convey any stress and vibration onto the Chiller and have sufficient space for maintenance purpose.
- On each water box of evaporator and condenser, it is requested to install air-vent cock, drain valve and piping as well.
- It is strongly to install strainers on each inlet of evaporator and condenser in order to filter foreign materials. If the foreign materials are flowed into the heat exchanger, there is high possibility of decreasing performance.
- It is recommended to install thermometer, pressure gauge and flow meter to measure the chiller operational condition.

Control of cooling water temperature

As a standard, 10kg/cm² of standard flange is adopted for evaporator and condenser nozzles. In general, if the atmospheric temperature falls lower than design temperature condition cooling water from the cooling tower decrease as well. Therefore, for whole-year-operation chillers, it is strongly recommended to control the cooling tower fan according to outlet temperature of cooling tower and adopt by-pass system in parallel. The by-pass system is positioned on the outlet of cooling water and bypass the cooling water through 3-way control valve working at condensation pressure.

The 3-way control valve can be alternated with 2 units of butterfly valve. The system should maintain min. 14 degree C of temperature difference between cooling water outlet and chilled water outlet.

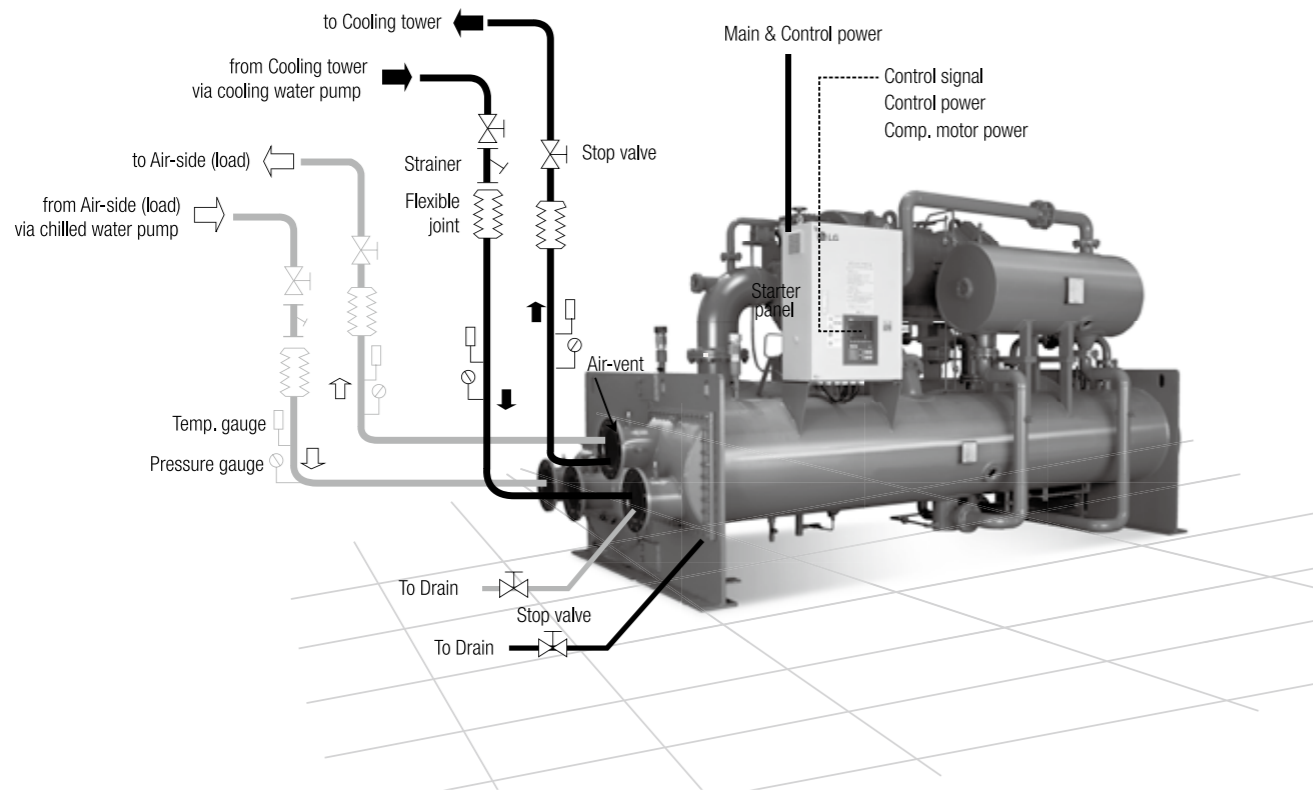

Notes: 1. Control power - 3Phase/220V/50Hz(60Hz) - should be provided by the customer apart from main power source.
2. The Main power wiring to the starter and 2nd wiring between the chiller and starter must be done based on local regulation. And the work scope is purchaser's.

Materials

Item	Material	Specification(Equivalent)
Shell Plate	Hot rolled steel	SA 516 Gr. 70
Tube Sheet	Hot rolled steel	SA 516 Gr. 70
Water-box	Hot rolled steel	SA 516 Gr. 70
Tubes	Finned copper tube	SB 359 C12200
Discharge and Suction	Steel	SA 106 Gr. B
Impeller	Al alloy	SB 209
Impeller Casing	Cast iron	SB 48
Pipe	Steel	SA106 Gr. B
Flange	Steel	SA 516
Support	Steel	SA 516 Gr. 70

Note: 1. Specification is an equivalent code in ASME(American Society of Mechanical Engineers)

Insulation

The factory insulation shall include evaporator, suction line up to the compressor suction housing; compressor motor and motor cooling return lines. The insulation shall be completed with 19mm as a standard and 38mm as an optional thickness of rubber sponge .

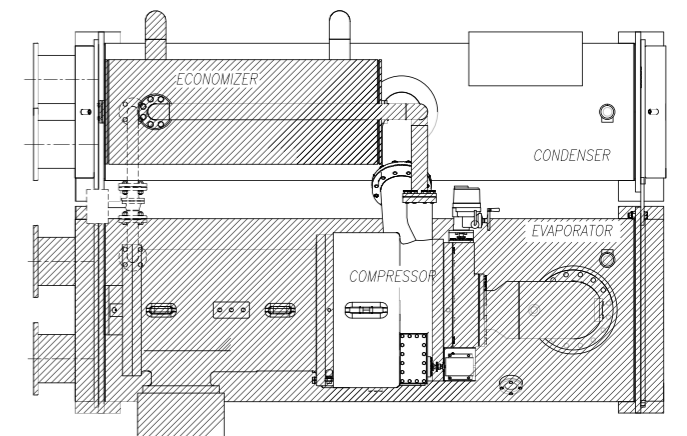

Top View

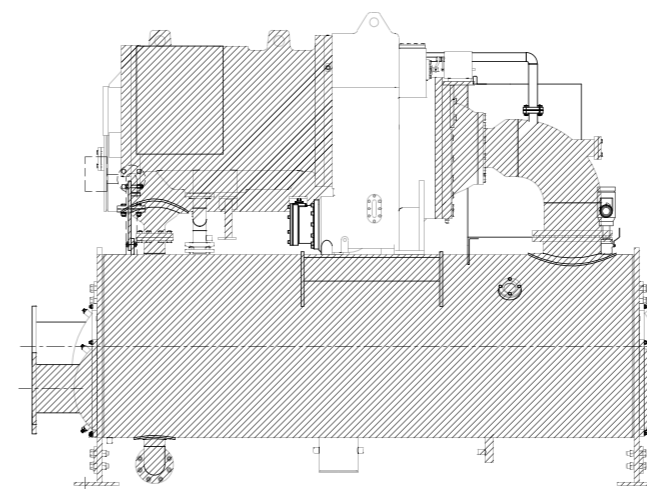

Front view

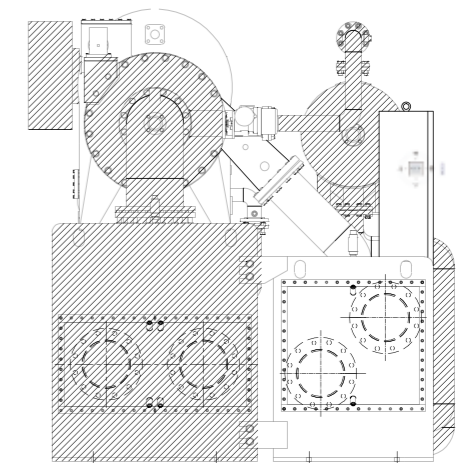

End view

Guide specification



Centrifugal chiller RCWF H series (2-stage, HFC-134a)

Contents

- Part 1. Range of application
- Part 2. General information
- Part 3. Equipment specifications
- Part 4. Scope of construction
- Part 5. Scope of supply
- Part 6. Warranty & service
- Part 7. Notes



Guide specification



Part 1. Range of application

This guide specifications is applied to all the models of the two-stage HFC-134a centrifugal chillers(RCWFH**) manufactured and supplied by LG Electronics.

Part 2. General information

2.1 System structure

- 1) The high-efficiency centrifuge chiller shall use a cycle of 2-stage compression and 2-stage expansion. It shall also use a variable capacity diffuser at the rear end of the 2-stage impeller so that it can work stably even under lower load.
- 2) Economizer shall be an external type for easy maintenance and the condenser shall include an independent sub-cooled heat exchanger.
- 3) The refrigerant level controller installed in the condenser and economizer shall be controlled by a micom to provide a cycle so that high efficiency can be achieved under full load and partial load.
- 4) The compressor shall be a semi-hermetic type to secure reliance for refrigerant leakage and the motor shall be cooled by refrigerant to keep low temperature of motor wire to get high efficiency.

2.2. Performance and quality

- 1) The product shall satisfy the performance requirements of AHRI(Air Conditioning, Heating And Refrigeration Institute) Latest Standard 550-590/551-591.
- 2) As the refrigerant, R-134a, environmental refrigerant with Ozone Depleting Potential(ODP) of zero, shall be applied.
- 3) The pressure vessel shall be designed and inspected in accordance with KGS Code(High-Pressure Gas Safety Control Act) or ASME SEC.VIII(Options) or PED(Pressure Equipment Directive) and certified by the relevant certification agency.

Part 3. Equipment specification

3.1 System structure

The chiller is composed of compressor/motor, evaporator, condenser, external flash tank type economizer, oil system, automatic expansion valve, inlet guide vane, refrigerant piping, control panel, starter, safety devices, and insulation / isolator.

3.2 Compressor/motor

- 1) The compressor is a high-efficiency semi-hermetic and centrifugal 2-stage type for HFC-134a. The impeller is made of high-strength special aluminum alloy and integrated with Return Channel which makes static pressure recovery in flow path and stable inlet between 1st and 2nd impellers for minimizing efficiency loss. Also it can be helpful for easy

maintenance.

- 2) The motor shall be a liquid refrigerant-cooled type and insulated by anti-humidity materials to prevent condensation. It shall be applicable for 380-13,800V, 50/60Hz and 3Ph. The motor shall have a both-end support structure and built-in motor coil temperature sensors for real-time control by the control panel.
- 3) The motor coil shall be specially insulated to have refrigerant resistance for HFC-R134a and oil resistance for applied oil.
- 4) A variable diffuser shall be adopted for optimized partial load performance and stable operation in low load condition. And an independent motor controlling the variable diffuser shall be provided with corresponding to IGV opening ratio.
- 5) Ball or tilting pad type bearing shall be applied. It should include an extra oil sump for constant lubrication for a while after oil pump stop.
- 6) The inlet guide vane should have multiple vanes to minimize the flow loss at the entrance of the impeller.
- 7) For a stable operation of high-speed radial and axial bearing, two(Including one for spare) bearing temperature sensors shall be installed to monitor and manage the temperature in real time.

3.3 Oil system

- 1) A trochoid type semi-hermetic oil pump shall be adopted for constant and stable oil supply with low noise / vibration, while allowing the oil volume control by the control valve.
- 2) The oil pump motor shall be insulated to be refrigerant resistant to HFC-134a and oil resistant to the applied oil. It should be a built-in type and structured to supply oil always stably from the oil tank.
- 3) The oil filter shall be removable by installing the valve at the both-end and it should include the purge valve and drain plug.
- 4) The oil cooler shall include an external plate type heat exchanger, which is durable and easy for maintenance, at the rear end of the filter.
- 5) The oil heater shall be controlled to keep oil temperature to have proper viscosity possible to supply oil to bearings and can be replaced.
- 6) The gas piping for the refrigerant which returns from Gear Box shall include an external type oil separator to minimize the oil carry over to heat exchangers.

3.4 Evaporator, condenser(Including subcooler) and economizer

- 1) Evaporator and condenser shall have a shell & tube structure and include high-efficiency heat-exchanging tubes. The tubes shall be installed with expanded both ends for easy maintenance. Tube Sheet has holes for the tube fixing on the plate which shall have 2 grooves for protection from leakage.

- 2) The evaporator shall have 10mm size or less perforated plate structure which can distribute the refrigerant uniformly. The evaporator shell has enough space in upper side to prevent liquid carry-over.
- 3) The condenser shall have a collision prevention plate, at the gas inlet, which protect tubes from gas jet through discharge pipe.
- 4) The heat-transfer tubes shall be machined to encourage heat transfer performance inside and outside the tube and parts in contact with tube sheets and tube support plates shall not be machined. The tube support plates for heat-transfer tubes shall be designed for stable support in accordance with TEMA and ASME standards.
- 5) The pressure vessel shall be designed and inspected in accordance with KGS Code(High-Pressure Gas Safety Control Act) or ASME SEC.VIII(Options) or PED(Pressure Equipment Directive) and certified by the relevant certification agency.
- 6) On the top of the evaporator and condenser, a safety valve shall be installed in accordance with KGS Code (High-Pressure Gas Safety Control Act) or ASME SEC.VIII (Options). Spring type relief valves are in accordance with ANSI/ASHRAE STANDARD 15-1994 code.
- 7) Water box shall be designed to select 10kg/cm², 16kg/cm², or 20kg/cm² according to the water pressure with a structure of air vent on the top and drain on the bottom. The water box for 16kg/cm², 20kg/cm² shall be structured to secure high strength and reliance at high pressures.
- 8) The economizer shall be an external type that allows service and operation management. Inside the economizer, the liquid and gas shall be fully separated. Perforated plates shall be installed inside the economizer to prevent liquid carry-over.

3.5 Refrigerant level and flow controller

- 1) The condenser and economizer shall be equipped with the level control equipment to keep optimal cycle under full and partial load. It shall control two refrigerant flow control valves installed in the liquid pipe to keep the refrigerant optimal in each cycle.
- 2) Condenser shall have a refrigerant level control sensor with a butterfly valve for automatic level control and economizer shall have a floating type automatic valve for level control.
- 3) The condenser shall store enough refrigerant under partial load, to allow stable motor cooling and oil cooling even during low temperature cooling operation.

3.6 Control panel

- 1) Structure
The control panel shall consist of Micom module(HMI/MASTER/SLAVE/Vane Control module), a power supply for supplying stable power, breakers for controlling and safety,

- an electronic contact, and relays for controlling.
- 2) HMI/MASTER/SLAVE module
The module shall use high-performance microprocessor to perform the control function optimized for the equipment. The high-precision analog/digital(A/D) converter shall monitor the values of the temperature sensors to display the values on the screen, and apply them to the controlling. The RS-485 communication port is embedded by default to support the remote monitoring and controlling by customers. Customers simply select RS-485 for their building automation.
 - 3) Indication and operation key module
The indication and operation key module consists of a display indicating operating data, set points required for the equipment operation, and data of abnormality in characters; a key input section for entering the data or selecting menus; and a LED lamp indicator section showing the equipment operation shutdown conditions important for the operation of the equipment, the operation of the compressor, the oil pump, the oil heater, the flow of chilled water/cooling water, alarm status, the selected manual actuation of the vanes, and the selected manual operation of the oil pump. In particular, the module allows operators to directly access the frequently used keys, and select other operations from the menu for improving the convenience of operators. The operation keys consist of: four menu operation keys, three manual operation keys for the vanes, three manual operation keys for the oil pumps, and two operation/shutdown key for the operation and the shutdown of the equipment. If the operation keys are inoperable, operators shall be able to use the character display and the menu selection keys to operate the equipment from the menu. The display shall show the following operation conditions in Korean, Chinese or English: the temperature of the inlet and the outlet of the chilled water and the cooling water, the compressor discharge temperature, the oil tank temperature, the motor bearing temperature, the condenser pressure, the evaporator pressure, the oil tank pressure, the oil pump pressure, the operating current and the vane opening. The I/O is composed of a digital input section for monitoring the operating conditions of the switches and a digital output section for controlling the operation of the equipment. A photo coupler is mounted on the I/O section for preventing noises, and receives/transmits all the data through communication with the main module to prevent malfunctions caused by electronic waves generated from the data transmission through the cables.

3.7 Features of controller

- 1) Convenient operation data management
A wide 7 inch Color Graphic LCD(800x480) is used to display various pieces of operation information on a single screen, and stores the analog data(e.g., temperature data)

- up to over 200 cases per channel in the intervals defined by customers for keeping daily operation logs. The real-time display also shows the temperature of the chilled water outlet and the operating current of the compressor motor in graphics for easily identifying the trends of the changes to the temperature and operating current.
- 2) Self-diagnosis and failure history storing
The Micom monitors the conditions of the equipment during shutdown and operation, and notifies operators of the conditions of the equipment by displaying characters, alarm lamps and buzzers, and stores the time and the log of failures for maintenance. In particular, the Micom classifies failures into minor failures and major failures. If a minor failure takes place, the Micom displays the details of the failure in characters and continues the operation of the equipment to minimize the shutdown of the equipment.
 - 3) Optimized artificial intelligence control algorithm for chiller control
 - Flexible Startup
The vane is slowly operated to prevent impacts on the equipment such as the surge generated from a rapid increase in load at the startup of the equipment.
 - Digital PID Control
When the manual mode is changed to the auto mode, the digital PID control integrated with the flexible startup shall recognize the optimal PID control points automatically to minimize the unnecessary shutdown of the equipment and reflect them to the control equation to control the temperature stably and precisely.
 - Preventive Operation
The temperature and the pressure of the components are measured in real-time during operation and the primary and secondary preventive operations are performed in accordance with the measurement results to prevent the shutdown of the chiller caused by the overload, the high pressure of the condenser, the low pressure of the evaporation, and surges.
 - Scheduled operation
The scheduled operation function is provided for the convenient operation of the equipment, which allows the selection of the operation/shutdown and the setting of the control temperature per day of the week, per holiday or 11 times a day
 - Service functions
The following service functions are supported for easy maintenance:
* Displaying the count of startups and the total operation hours of the pumps and the motors mounted on the body.
* Printing the operation and the trouble data.(Optional)
 - 4) Powerful customer support functions
 - Help
The help function memorizes the details of failures and shows the descriptions for corrective actions when the

- operator selects a particular failure from the menu, in order to improve the convenience for operators.
- Communication for building automation and remote monitoring and control the communication function is embedded by default(RS485/Modbus RTU) for connecting the equipment with the monitoring system of customers. The zero-voltage I/O function is provided for remote operation and shutdown by using a simple electric wiring, or for monitoring the operating conditions of the equipment. In addition, BACnet or Modbus/TCP is optionally mounted for improving the operation of the equipment for the convenience of customers.
- 5) Indicator lamp
All indications are displayed in characters on the LCD which turns on in the following 8 cases.
 - Chiller RUN/STOP
 - Compressor operates
 - Oil pump operates
 - Oil heater operates
 - Chilled water flow normal
 - Cooling water flow normal
 - Vane manual
 - Oil pump manual/auto

3.8 Starter

- 1) The starter is a standalone closed starter equipped with the embedded EOCCR(Electric Over Current Relay) protective relay for over-current, short, phase loss, reverse phase, unbalance and restrictions. The starter is mounted with the following components: a voltmeter, an ammeter, a voltage selection switch, a current selection switch, a power indicator lamp, an operation indicator lamp, an alarm indicator lamp, a shutdown indicator lamp, a breaker for protecting circuits, and a RESET switch.
- 2) Protective relay
EOCCR(Electric Over Current Relay) protective relay should be installed.(Over-current, short, phase loss, reverse phase, unbalance and restrictions)
* The ground fault circuit interrupter is optional and will be installed as required by customers.
- 3) Operation and instrument panel
Indicator lamps, breaker for protecting circuits, voltmeter, ammeter, voltage and current phase conversion switch
- 4) Indicator lamp: turns on in the following three cases.
 - Power indicator lamp(White)
 - Operation indicator lamp(Red)
 - Stop indicator lamp(Green)
 - Fault indicator lamp(Yellow)

3.9 Safety devices

- 1) Chilled Water Low Temperature [temperature sensor at chilled water outlet] _ Protect the evaporator from freeze.

- 2) Evaporator Low Pressure [evaporator pressure sensor] _
Protect evaporator from abnormal low pressure
- 3) Condenser High Pressure [condenser pressure sensor] _
Protect chiller from abnormal high pressure condenser
- 4) Motor High Temperature [motor temperature sensor] _
Protect motor from abnormal high temperature coil
- 5) Bearing High Temperature [bearing temperature sensor] _
Protect compressor from abnormal temperature bearing
- 6) Oil Differential Low Pressure [oil tank & discharge-side pressure sensor] _ Protect compressor from abnormal oil supply differential pressure
- 7) Oil High Temperature [oil tank temperature sensor] _
Protect compressor from high oil temperature
- 8) Oil Low Temperature [oil tank temperature sensor] _
Protect compressor low oil temperature
- 9) Chilled Water Pump Abnormal [interlock with chilled water pump] _ Protect chiller from chilled water pump
- 10) Cooling Water Pump Abnormal [interlock with cooling water pump] _ Protect chiller from abnormal cooling water pump
- 11) Chilled Water Flow Rate Abnormal [chilled water differential pressure switch] _ Protect chiller from abnormal chilled water flow rate
- 12) Cooling Water Flow Rate Abnormal [cooling water differential pressure switch]_ Protect chiller from abnormal cooling water flow rate(Optional)
- 13) Surge Abnormal [control panel] _ Protect compressor from surges
- 14) Oil Pump Over-Current [over-current relay] _ Protect compressor from motor/oil pump over-current
- 15) Motor Reverse Phase/Phase Loss/Over-Current _ Protect chiller from motor reverse phase / phase loss / over-current
- 16) Safety Valve [evaporator/condenser] _ Discharge chiller protective refrigerant when the pressure is abnormally high
- 17) Current Limiting Function [control panel] _ Operation current limited operation, compressor protection / user convenience

* The temperature of the cooling water shall be adjusted to keep the temperature difference 14 degree °C or higher between the chilled water outlet and the cooling water outlet.

3.10 Isolator

The isolator consists of the sandwiched vibration proof pads of rubber and cork in accordance with the standards. An optional special spring isolator shall be applied if the structure that supports the chiller can easily vibrated by the chiller(Optional).

3.11 Cold insulation

Cold insulation Standard Specification is NBR material of 19mm or more in thickness and KS or equivalent standard products are to be applied. However the thickness can be designed and applied to prevent of condensation by customer's requirements and conditions of use.

3.12 Start-up commissioning

A LG engineer or an engineer for the start-up commissioning shall carry out start-up commissioning and provide the operation training. Provide capacity control system capable of reducing unit capacity to 25% of full load.

Part 4. Scope of construction

Items	Supplied By	Notes
Painting	LGE	Body : Dawn gray Starter panel : Warm gray Control panel : Warm gray
Cold insulation	LGE	Cold-insulate the external side of evaporator, chilled water box, and motor. The material is NBR of 3/4"(19mm) and its color is black.
External piping	Customer	External piping work for chilled water, cooling water and drain
Control system wiring (On the secondary side)	Customer	Control wiring between the starter panel and the control panel
Power system wiring (On the secondary side)	Customer	Power and ground wiring between the chiller and the starter panel
Control power	Customer	Control power of 3ph, 380V shall be supplied to the starter panel.(Minimum power capacity: 4kVA)
Building and foundation	Customer	Completing the foundation construction prior to installing the chiller
Interlock wiring of the chilled water pump and the cooling water pump	Customer	Wiring between the control panel and the pump control panels
Relief valve vent piping	Customer	Piping for discharge of refrigerant in emergency

Part 5. Scope of supply

Items	Supplied By	Notes
Centrifuge chiller body	LGE	Refer to the body components
Refrigerant (R-134a)	LGE	Delivery with refrigerant charged (Divide or deliver separately if required)
Lubrication oil	LGE	Delivery with oil charged or separate delivery with chiller
Isolator pad	LGE	Vibration absorption pad
Spare parts	LGE	Provide spare parts as on option if customer is required
Chiller manual	LGE	Installation and operation manual
Leveling plate	LGE	Parts for leveling the centrifuge chiller
Starter panel	LGE	Compressor motor starter (Customer may select)

Part 6. Warranty & Service

6.1 The warranty period shall be the earlier of the following two: "1.5 years of product delivery" or "one year of start-up commissioning.

6.2 An failure, caused by a defect in the parts, material, or operation caused during the warranty period, will be inspected by LG ELECTRONICS and fixed free of charge if we agree that it is defective.

6.3 Warranty is not applicable for the following cases

- 1) If a failure occur after the product is repaired at the shop that is not designated by LG.
- 2) If the failure is caused by user's mistakes in using and handling the equipment.
- 3) If the product is resold or transferred to others during the warranty period.
- 4) If a failure caused due to a fire or a natural disaster.

Part 7. Notes

7.1 All specification about the manufacturing shall be submitted to the customer side to get the approval from them before the chiller manufacturing can be started. Any requirement not specified here shall be discussed with and approved by the customer before execution.

7.2 When reselling or transferring the product to another party before discarding them, notify LG Electronics.