

SCROLL COMPRESSOR

COMPRESSOR TECHNOLOGY
FOR HVAC &
LIGHT COMMERCIAL APPLICATIONS

GLOBAL NETWORK

Changwon, Korea

- Address 76 Seongsan-dong, Changwon City Gyeongnam, 641-713, South Korea
- Phone +82-55-269-3868
- Fax +82-55-268-4896
- Website www.lge.com/global/business

Tianjin, China

- Address No. 9 Jin Wei road, Bei Chen Dist, Tianjin, China
- Phone +86-22-2690-3251

Atlanta, USA

- Address 4300 North Point Pkwy Suite #100 Alapretta, GA 300 22
- Phone +1-678-328-6433

Dallas, USA

- Address 2422 Farmers Branch, Texas 75234,
- Phone 1-214-256-7835

For continual product development, LG reserves the right to change specifications without notice.
© LG Electronics Inc. Printed in Korea. Oct, 2019



WHY LG COMPRESSOR?

LG Component Solutions Business Unit offers meaningful and unique solutions to meet modern sustainability standards with environmentally sound and energy-efficient technologies.

To continue to deliver the highest level of satisfaction to all our partners, we will continue with our technological advancements to supply only the best sustainable components and inverter total solutions optimized for residential and commercial environments.

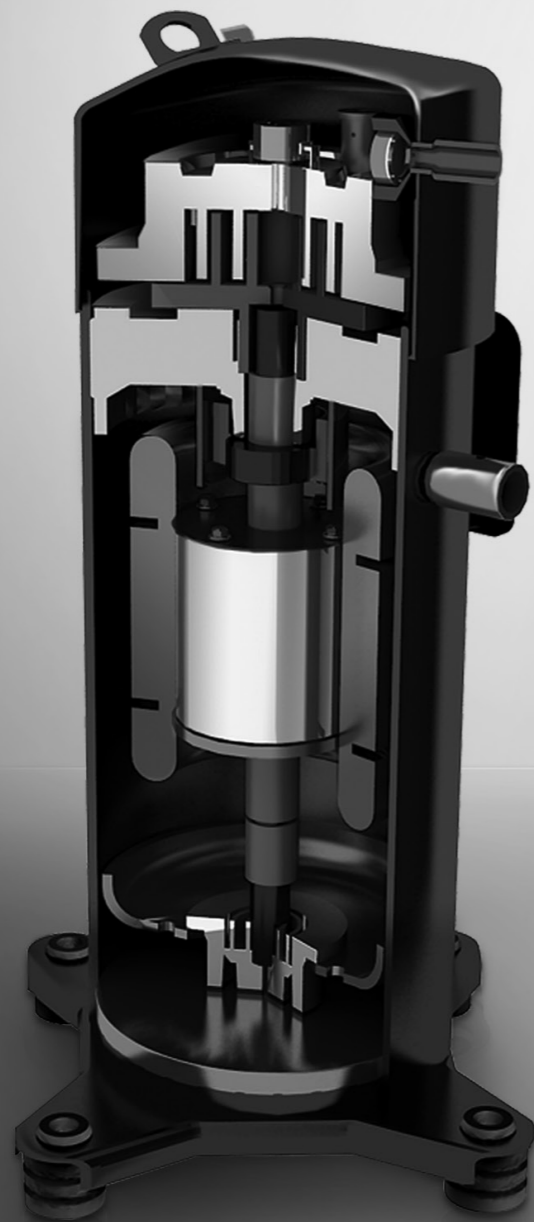

TECHNOLOGY

LG compressors are a group of high-precision machinery and assembly technologies continuously designed to perform even under the most challenging environments. Built with today's leading core technology, inverter motor and drive for optimized products developed to work around the world's evolving needs.

MODEL VARIETY

LG offers an extensive product selection of scroll compressors for fixed speed, two stage modulating and variable speed with optimized inverter driver, to fully support your various business needs and applications

CUSTOMER SUPPORT

Enabling customers for optimal business performance, LG offers technical support to ensure our products are delivered with the differentiated level of quality verifiable through our highly qualified R&D process.

QUALITY

With worldwide recognition for high product quality and sustainability, LG ensures all products are delivered at full value with production quality and safety checks to ensure full customer satisfaction.

MILESTONES & GLOBAL SITE

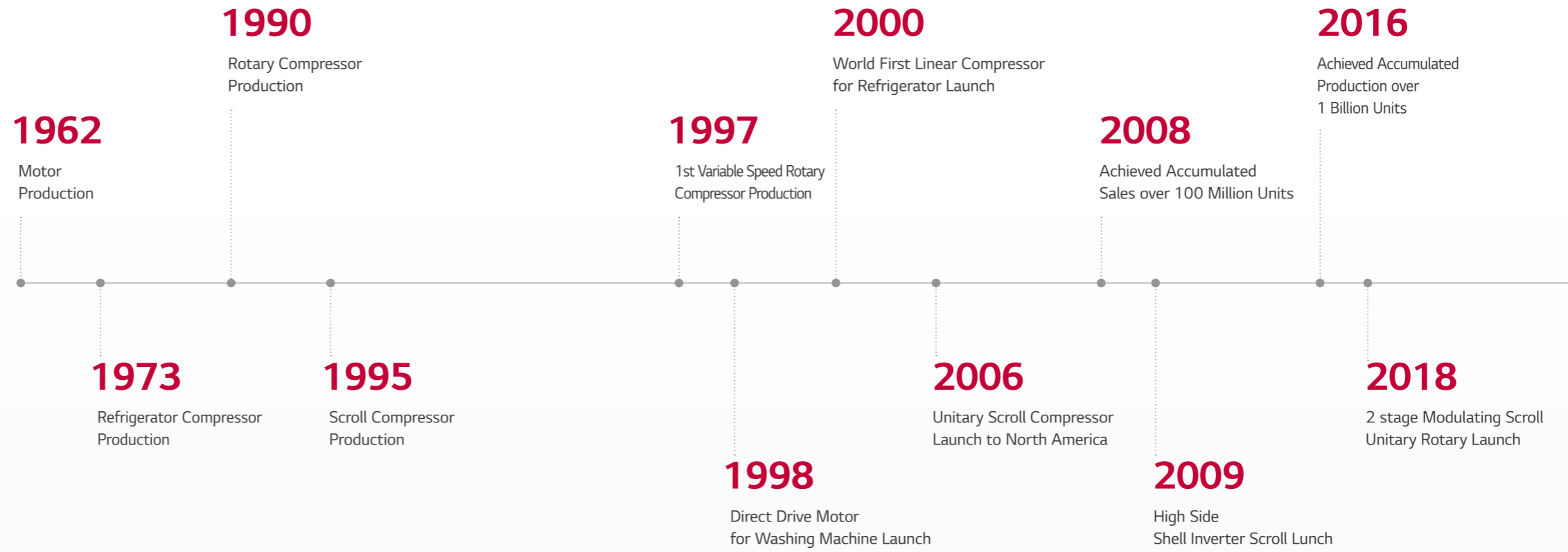

○ SALES OFFICE 12 SITE

○ FACTORY 7 SITE

Linear	Korea, China (Taizhou)
Reciprocating	Korea, China (Taizhou), India (Noida)
Rotary	Korea, China (Tianjin), Thailand (Rayong)
Scroll	Korea, China (Tianjin)
Casting	China (Qinhuangdao)

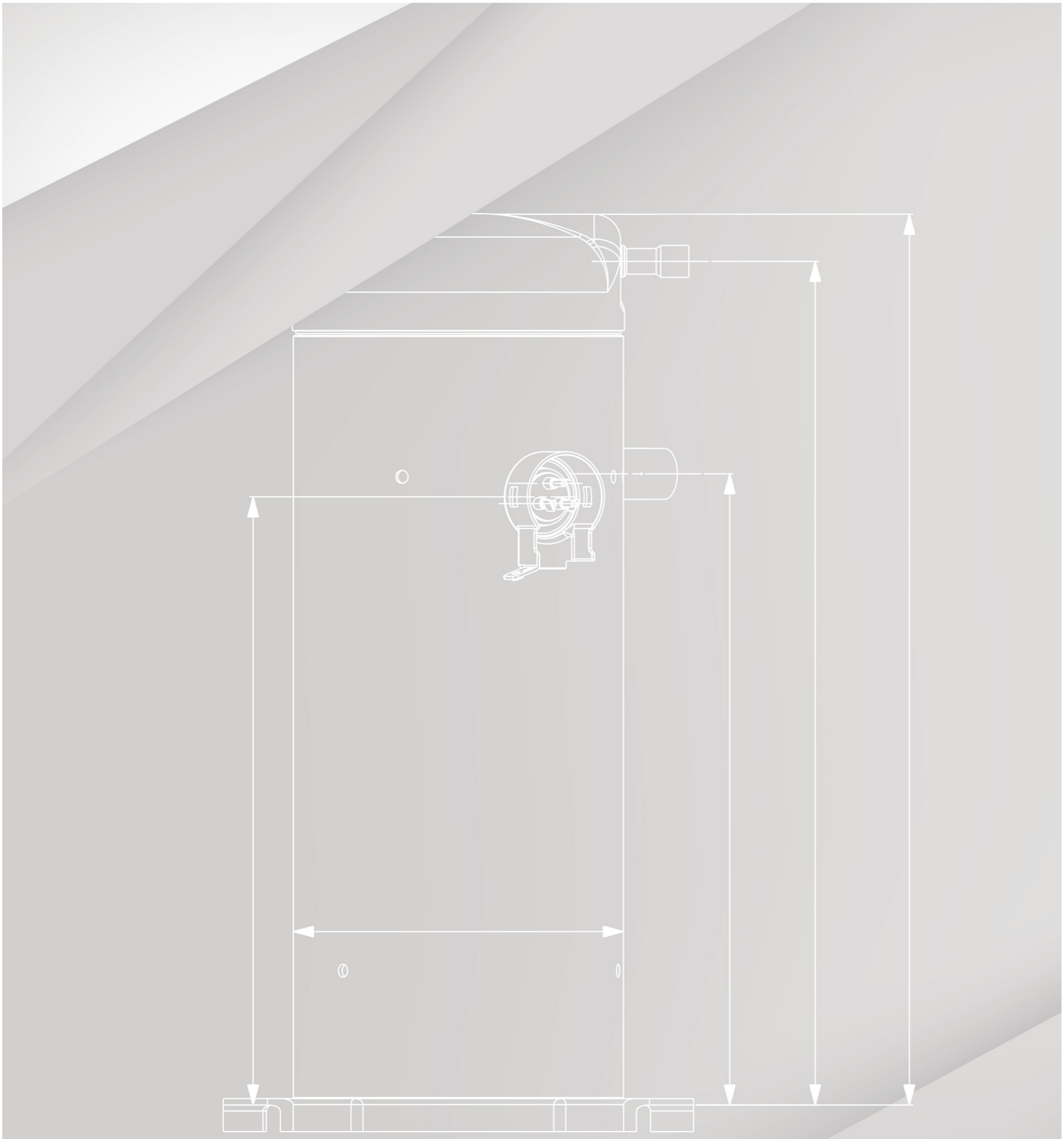

CONTENTS

Why LG Compressor?	01
Milestones & Global Site	02
LG Scroll Compressor	
- Product Range	06
- Nomenclature	07
- Specification Fixed Speed R410A	08
- Specification Fixed Speed R22	18
- Specification 2 Stage Modulating R410A	20
- Specification Variable Speed R410A / R32	22
- Specification Special Application	24
- Specification Drive	30
- Wiring Diagram	31
- Mounting	31
- Accessory Parts	31
- Packing & Container Stuffing Quantity	31

Product Range

Fixed Speed

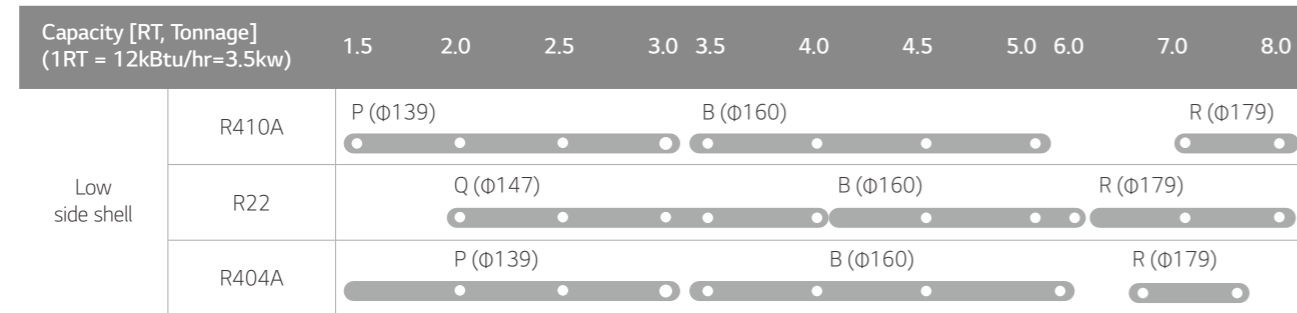

2 Stage Modulating

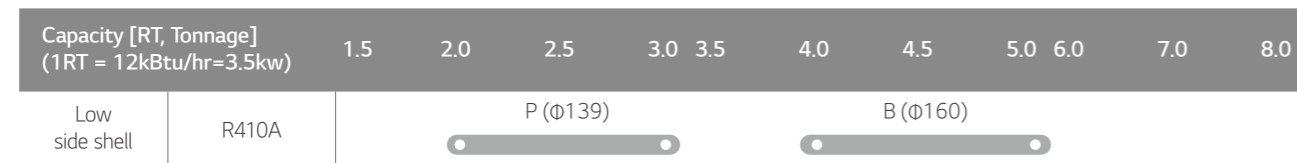

Variable Speed

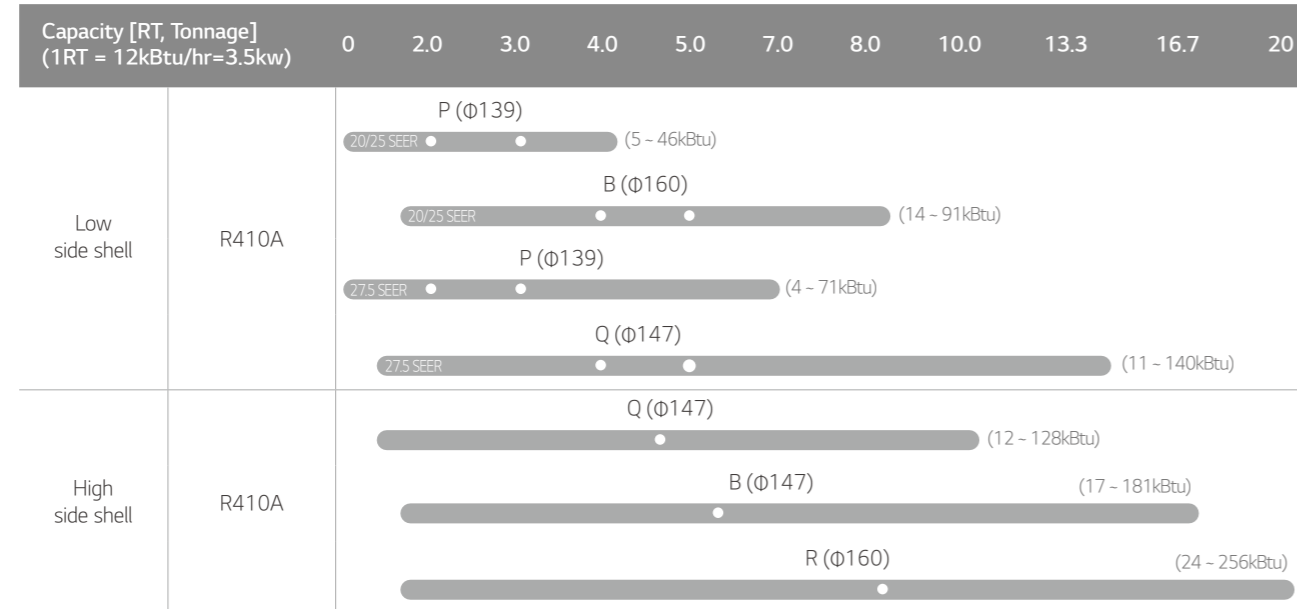

Nomenclature

A P A 026 D A A

Refrigerant

Code	Refrigeran	Type
A	R410A	LSS
H	R407C	LSS
J	R410A	HSS
M	R404	LSS
S	R22	LSS

Compressor size (mm)

P : Φ139 R : Φ179
 Q : Φ147 G : Φ224
 B : Φ160

Generation code

(A-Z)

Capacity

(Btu/Hr x 1,000) @ 60Hz

Exterior specification
(A-Z)

Motor specification
(A-Z)

Motor code

Series	Power source (V)			Motor
	Phase(Φ)	V	HZ	
C	1	115	60	Fixed Speed
G	1	220	60	Fixed Speed
H	1	220	50	Fixed Speed
J	1	200 / 220	50	Fixed Speed
K	1	208-230	60	Fixed Speed
P	1	265	50	Fixed Speed
Q	1	265	60	Fixed Speed
Y	3	330 / 420	50	Fixed Speed
U	3	380	60	Fixed Speed
D	BLDC Inverter			BLDC / Distributed
M	BLDC Inverter			BLDC / Distributed

Specification

Fixed Speed R410A [1 of 5]

Refrigerant	Type	Frequency	Voltage	Series	Model	Cooling capacity		Input	EER	COP	Test condition (Cond / Eva Temp)	
						Btu/hr	Watts	Watts	Btu/W-hr	W/W	°F	
R410A	LSS	50Hz	1φ, 220/240V	ABT	ABT034PT	28,000	8,201	2,888	9.7	2.84	130 / 45	
					ABT042YT	34,900	10,228	3,421	10.2	2.99	130 / 45	
					ABT048YT	40,200	11,781	3,688	10.9	3.19	130 / 45	
				ABT	ABT051YT	42,500	12,447	3,900	10.9	3.19	130 / 45	
					ABT054YT	44,800	13,121	4,150	10.8	3.16	130 / 45	
					ABT057YT	48,500	14,204	4,450	10.9	3.19	130 / 45	
					ABT061YT	51,500	15,083	4,725	10.9	3.19	130 / 45	
					ARA	ARA061YA	51,500	15,093	5,049	10.2	2.99	130 / 45
						ARA073YA	62,000	18,170	6,020	10.3	3.02	130 / 45
				ARA073YB		63,000	18,463	5,833	10.8	3.17	130 / 45	
				ARA081YA	68,500	20,075	6,716	10.2	2.99	130 / 45		

Note : COND 130°F(54.4°C), EVA 45°F(7.2°C)

Cooling capacity		Input	EER	COP	Test condition (Cond / Eva Temp)	Dimension (mm)		
Btu/hr	Watts	Watts	Btu/W-hr	W/W	°F	A	B	C
						444	421	315
						415	377	273
						444	421	315
						444	421	315
						444	421	315
						444	421	315
						474	430	322
						470	426	322
						461	412	308
						379	426	322

- ABT

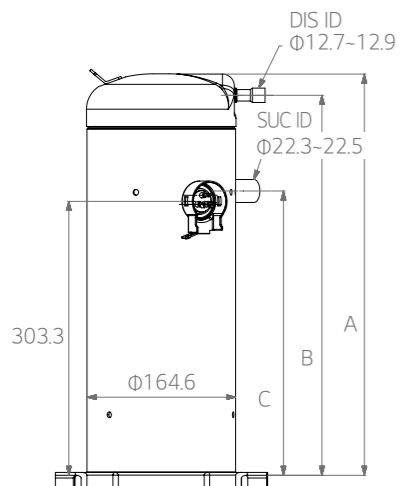
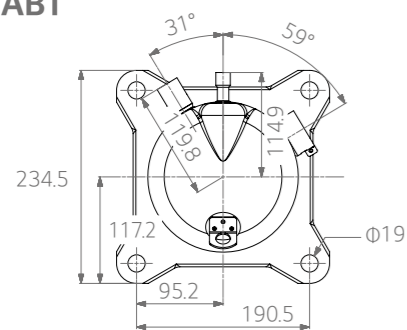

- ARA

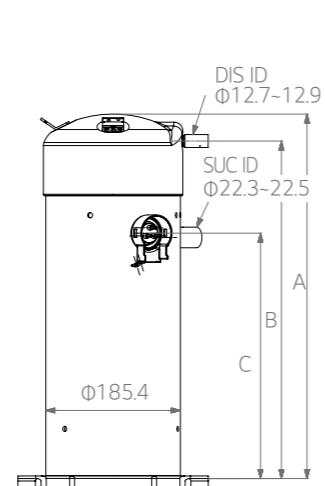
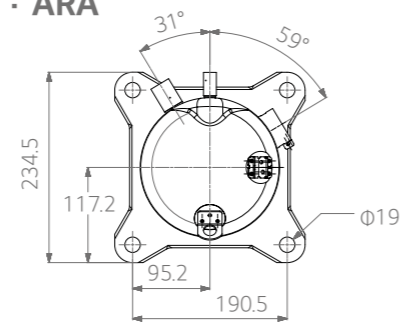

Specification

Fixed Speed R410A [2 of 5]

Refrigerant	Type	Frequency	Voltage	Series	Model	Cooling capacity		Input	EER	COP	Test condition (Cond / Eva Temp)
						Btu/hr	Watts	Watts	Btu/W-hr	W/W	°F
R410A	LSS	60Hz	1Φ, 208-230V	APA	APA016KA	15,200	4,455	1,634	9.3	2.73	130 / 45
					APA020KA	19,500	5,715	2,010	9.7	2.84	130 / 45
					APA024KA	22,500	6,594	2,344	9.6	2.81	130 / 45
					APA026KA	24,500	7,180	2,450	10.0	2.93	130 / 45
					APA029KA	28,000	8,206	2,828	9.9	2.90	130 / 45
					APA030KA	29,000	8,499	2,929	9.9	2.90	130 / 45
					APA032KA	30,500	8,939	3,020	10.1	2.96	130 / 45
					ABA036KA	36,500	10,697	3,510	10.4	3.05	130 / 45
				ABA	ABA042KA	42,500	12,456	4,048	10.5	3.08	130 / 45
					ABA049KA	48,000	14,067	4,528	10.6	3.11	130 / 45
					ABA051KA	51,500	15,093	4,858	10.6	3.11	130 / 45
					ABA054KA	54,000	15,826	5,143	10.5	3.08	130 / 45
				ABT	ABT038KT	38,700	11,342	3,650	10.6	3.11	130 / 45
					ABT042KT	42,200	12,359	3,980	10.6	3.11	130 / 45
					ABT048KT	48,000	14,058	4,444	10.8	3.16	130 / 45
					ABT051KT	51,200	14,058	4,740	10.8	3.16	130 / 45
					ABT054KA	54,000	15,815	4,820	11.2	3.28	130 / 45

Note: COND 130°F(54.4°C), EVA 45°F(7.2°C) / COND 100°F(37.8°C), EVA 45°F(7.2°C)

Cooling capacity		Input	EER	COP	Test condition (Cond / Eva Temp)	Dimension (mm)		
Btu/hr	Watts	Watts	Btu/W-hr	W/W	°F	A	B	C
24,000	7,034	1,333	18.0	5.28	100 / 45	407	379	259
27,700	8,118	1,547	17.9	5.25	100 / 45	407	379	259
30,100	8,821	1,645	18.3	5.36	100 / 45	407	379	259
35,300	10,345	1,898	18.6	5.45	100 / 45	407	379	259
36,500	10,697	1,931	18.9	5.54	100 / 45	407	379	259
38,300	11,225	1,995	19.2	5.63	100 / 45	407	379	259
42,800	12,543	2,195	19.5	5.71	100 / 45	444	418	300
52,000	15,240	2,680	19.4	5.69	100 / 45	449	416	294
58,500	17,145	3,000	19.5	5.71	100 / 45	449	416	294
63,000	18,463	3,231	19.5	5.71	100 / 45	449	416	294
66,500	19,489	3,446	19.3	5.66	100 / 45	449	416	294
						449	416	294
						421	315	315
						421	315	315
						421	315	315
						421	315	259
						421	315	300

- APA

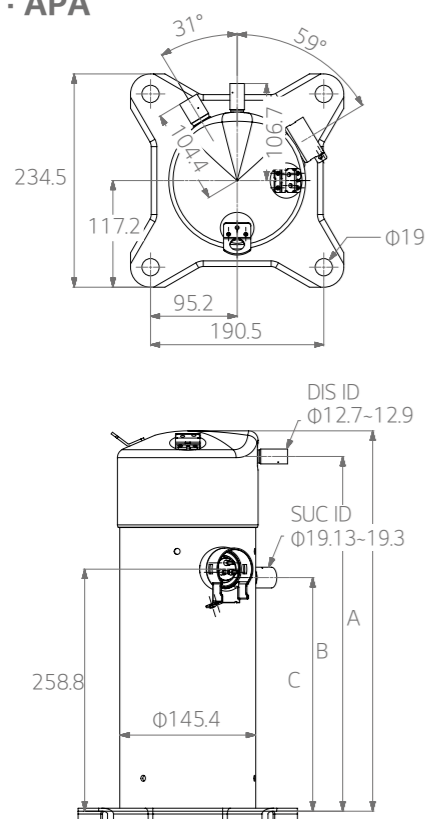

- ABA

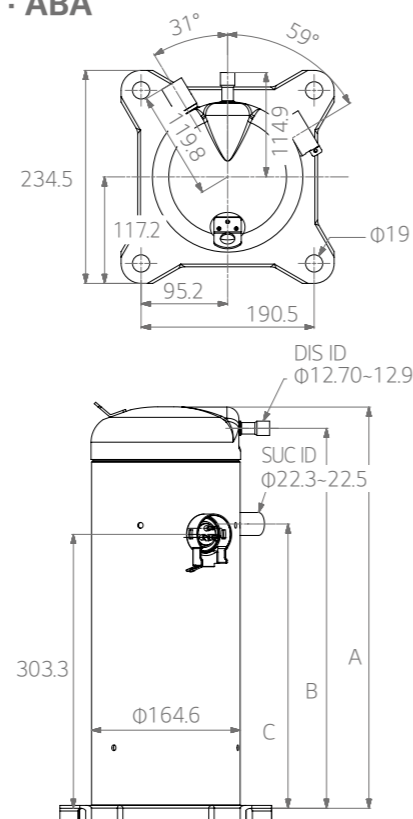

- ABT

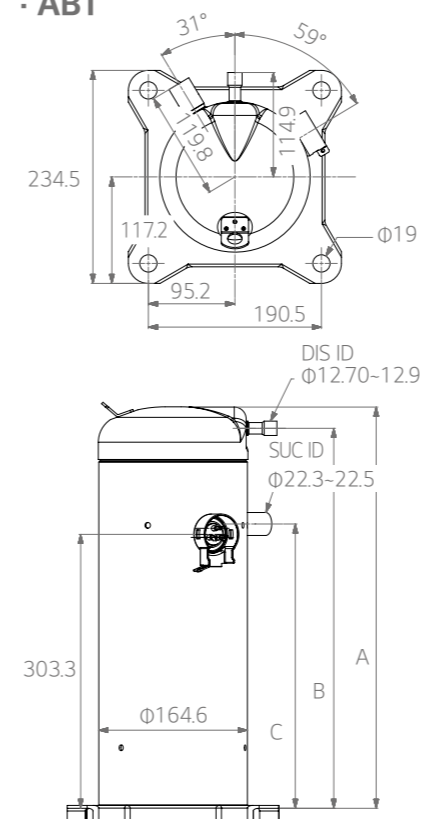

Specification

Fixed Speed R410A [3 of 5]

Refrigerant	Type	Frequency	Voltage	Series	Model	Cooling capacity		Input	EER	COP	Test condition (Cond / Eva Temp)	
						Btu/hr	Watts	Watts	Btu/W-hr	W/W	°F	
R410A	LSS	60Hz	3Φ, 208-230V	APA	APA032RA	30,000	8,792	3,030	9.9	2.90	130 / 45	
					ABA044RA	44,500	13,042	4,220	10.6	3.09	130 / 45	
					ABA051RA	51,500	15,093	4,813	10.7	3.14	130 / 45	
				ABA	ABA054RA	54,500	15,972	5,093	10.7	3.14	130 / 45	
					ARA061RA	61,500	18,024	6,029	10.2	2.99	130 / 45	
					ABT	ABT044RM	44,000	12,895	4,151	10.6	3.11	130 / 45
				ABT054RM		54,000	15,826	4,910	11.0	3.22	130 / 45	
				ABT044UM		44,000	12,895	4,151	10.6	3.11	130 / 45	
				3Φ, 380V	ABT	ABT048UM	48,300	14,146	4,555	10.6	3.11	130 / 45
						ABT048UT	48,500	14,204	4,410	11.0	3.22	130 / 45
						ABT054UM	53,500	15,669	4,953	10.8	3.16	130 / 45
					ARA	ARA061UA	62,800	18,405	5,980	10.5	3.08	130 / 45
			ARA081UA			81,500	23,885	8,316	9.8	2.87	130 / 45	
			APA032TA			29,800	8,734	3,010	9.9	2.90	130 / 45	
			3Φ, 575V	ABA	ABA044TA	44,500	13,042	4,220	10.6	3.09	130 / 45	
					ABA051TA	51,000	14,947	4,811	10.7	3.11	130 / 45	
					APA032WA	23,300 / 30,000	6,829 / 8,792	2,533 / 3,030	9.2 / 9.9	2.69 / 2.90	130 / 45	
			3Φ, 380/420V, 50Hz / 3Φ, 460V, 60Hz	ABA	ABA051WA	42,500 / 51,500	12,455 / 15,093	4,009 / 4,813	10.6 / 10.7	3.11 / 3.14	130 / 45	
					ABA054WA	44,400 / 54,000	13,012 / 15,826	4,353 / 5,143	10.2 / 10.5	2.99 / 3.08	130 / 45	

Note: COND 130°F(54.4°C), EVA 45°F(7.2°C) / COND 100°F(37.8°C), EVA 45°F(7.2°C), EVA 50°F(10°C)

Cooling capacity		Input	EER	COP	Test condition (Cond / Eva Temp)	Dimension (mm)		
Btu/hr	Watts	Watts	Btu/W-hr	W/W	°F	A	B	C
38,100	11,166	2,016	18.9	5.54	100 / 45	379	259	300
60,000	17,584	2,770	21.7	6.35	100 / 50	416	294	302
63,000	18,463	3,198	19.7	5.77	100 / 45	416	294	322
67,000	19,636	3,401	19.7	5.77	100 / 45	416	302	315
						430	322	315
						421	315	315
						421	315	315
						421	315	315
						421	315	315
						421	315	322
						421	315	308
						430	322	143
						461	412	308
37,600	11,019	1,979	19.0	5.57	100 / 45	407	379	259
60,000	17,584	2,770	21.7	6.35	100 / 50	444	418	300
63,000	18,463	3,198	19.7	5.77	100 / 45	407	379	259
29,700 / 38,100	8,704 / 11,166	1,641 / 1,984	18.1 / 19.2	5.30 / 5.63	100 / 45	444	418	300
52,000 / 63,000	15,240 / 18,463	2,613 / 3,198	19.9 / 19.7	5.83 / 5.77	100 / 45	449	416	294
55,000 / 66,500	16,119 / 19,489	2,821 / 3,410	19.5 / 19.5	5.71 / 5.72	100 / 45	449	416	294

- APA

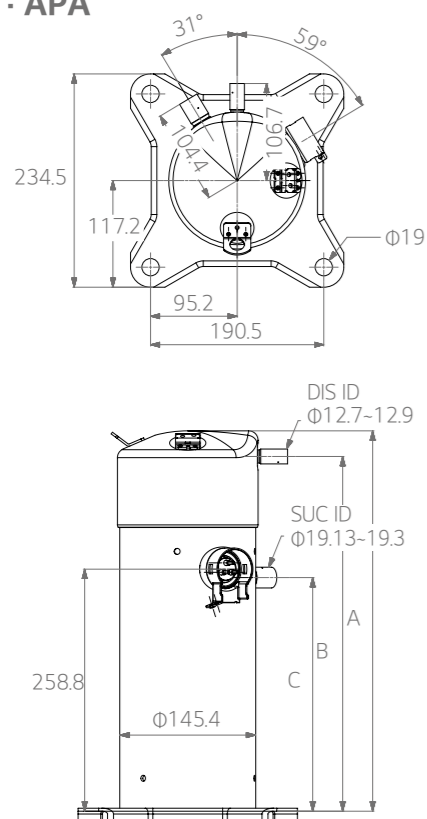

- ABA

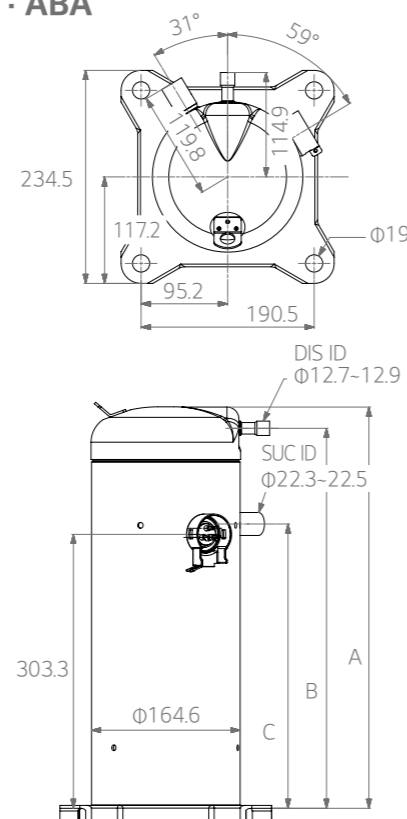

- ARA

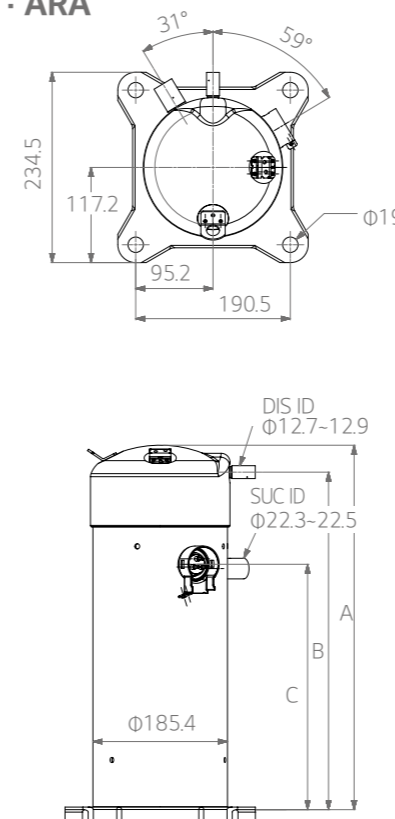

- ABT

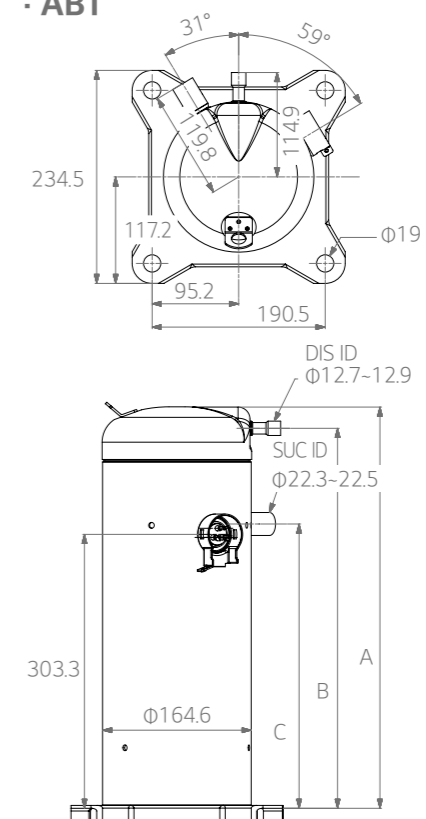

Specification

Fixed Speed R410A [4 of 5]

Refrigerant	Type	Frequency	Voltage	Series	Model	Cooling capacity		Input	EER	COP	Test condition (Cond / Eva Temp)
						Btu/hr	Watts	Watts	Btu/W-hr	W/W	°F
R410A	LSS	60Hz	1Φ, 208-230V	APG	APG014KA	14,600	4,276	1,505	9.7	2.84	130 / 45
					APG016KA	15,500	4,540	1,582	9.8	2.87	130 / 45
					APG016KB	15,500	4,540	1,550	10.0	2.93	130 / 45
					APG020KA	20,000	5,858	1,961	10.2	2.99	130 / 45
					APG020KB	20,000	5,858	1,961	10.2	2.99	130 / 45
					APG024KA	23,500	6,883	2,305	10.2	2.99	130 / 45
					APG024KB	23,500	6,883	2,282	10.3	3.02	130 / 45
				ABG	APG025KA	25,000	7,322	2,427	10.3	3.02	130 / 45
					APG029KA	28,800	8,435	2,743	10.5	3.08	130 / 45
					APG031KA	30,800	9,021	2,906	10.6	3.10	130 / 45
					ABG034KA	34,350	10,060	3,303	10.4	3.05	130 / 45
					ABG036KA	36,000	10,544	3,429	10.5	3.08	130 / 45
					ABG038KA	38,100	11,159	3,594	10.6	3.10	130 / 45
					ABG039KA	39,500	11,569	3,726	10.6	3.10	130 / 45
		60Hz	3Φ, 208-230V	APG	APG029RA	28,000	8,201	2,718	10.3	3.02	130 / 45
					APG031RA	30,300	8,874	2,942	10.3	3.02	130 / 45
					ABG038RA	38,000	11,129	3,620	10.5	3.08	130 / 45
				ABG	ABG042RA	41,500	12,154	3,952	10.5	3.08	130 / 45
					ABG049RA	49,500	14,497	4,583	10.8	3.16	130 / 45
					ABG051RA	51,000	14,937	4,722	10.8	3.16	130 / 45

Note : COND 130°F(54.4°C), EVA 45°F(7.2°C) / COND 100°F(37.8°C), EVA 50°F(10°C)

- APG

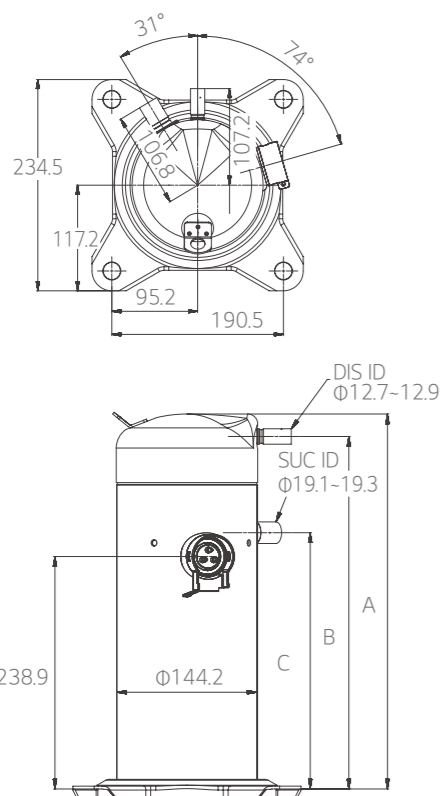

- ABG

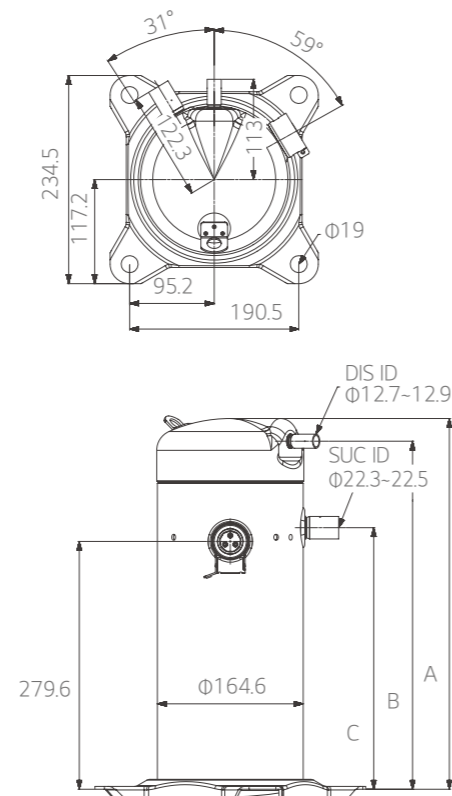

Cooling capacity		Input	EER	COP	Test condition (Cond / Eva Temp)	Dimension (mm)		
Btu/hr	Watts	Watts	Btu/W-hr	W/W	°F	A	B	C
20,100	5,887	957	21.0	6.15	100 / 50	385	362	263
21,300	6,238	1,039	20.5	6.00	100 / 50	385	362	263
21,400	6,268	1,019	21.0	6.15	100 / 50	385	362	263
27,300	7,995	1,294	21.1	6.18	100 / 50	385	362	263
27,300	7,995	1,264	21.6	6.33	100 / 50	385	362	263
32,700	9,577	1,521	21.5	6.30	100 / 50	385	362	263
32,900	9,636	1,516	21.7	6.36	100 / 50	385	362	263
35,000	10,251	1,606	21.8	6.38	100 / 50	385	362	263
39,600	11,598	1,808	21.9	6.41	100 / 50	385	362	263
42,800	12,535	1,937	22.1	6.47	100 / 50	385	362	263
47,150	13,809	2,214	21.3	6.24	100 / 50	419	394	295
49,400	14,468	2,298	21.5	6.30	100 / 50	419	394	295
51,400	15,054	2,369	21.7	6.36	100 / 50	419	394	295
53,000	15,522	2,477	21.4	6.27	100 / 50	419	394	295
57,100	16,723	2,631	21.7	6.36	100 / 50	419	394	295
67,300	19,710	3,087	21.8	6.38	100 / 50	419	394	295
69,500	20,355	3,188	21.8	6.38	100 / 50	419	394	295
39,000	11,422	1,822	21.4	6.27	100 / 50	385	362	263
41,700	12,213	1,949	21.4	6.27	100 / 50	385	362	263
51,600	15,112	2,367	21.8	6.38	100 / 50	419	394	295
57,100	16,723	2,370	21.7	6.36	100 / 50	419	394	295
67,400	19,740	3,092	21.8	6.38	100 / 50	419	394	295
69,500	20,355	3,188	21.8	6.38	100 / 50	419	394	295

Specification

Fixed Speed R410A [5 of 5]

Refrigerant	Type	Frequency	Voltage	Series	Model	Cooling capacity		Input	EER	COP	Test condition (Cond / Eva Temp)
						Btu/hr	Watts	Watts	Btu/W-hr	W/W	°F
R410A	LSS	60Hz	3Φ, 575V	APG	APG029TA	28,000	8,201	2,718	10.3	3.02	130 / 45
					APG031TA	30,000	8,786	2,913	10.3	3.02	130 / 45
				ABG	ABG038TA	37,800	11,071	3,600	10.5	3.08	130 / 45
					ABG042TA	41,500	12,154	3,952	10.5	3.08	130 / 45
					ABG049TA	49,500	14,497	4,626	10.7	3.13	130 / 45
					ABG051TA	51,000	14,937	4,766	10.7	3.13	130 / 45
		50/60Hz	3Φ, 380-420V, 50Hz	APG	APG029WA 60Hz	28,200	8,259	2,738	10.3	3.02	130 / 45
					APG029WA 50Hz	22,500	6,590	2,320	9.7	2.84	130 / 45
				APG	APG031WA 60Hz	30,000	8,786	2,913	10.3	3.02	130 / 45
					APG031WA 50Hz	24,100	7,058	2,485	9.7	2.84	130 / 45
			ABG	3Φ, 380-420V, 50Hz	ABG038WA 60Hz	38,000	11,129	3,619	10.5	3.08	130 / 45
					ABG038WA 50Hz	31,500	9,226	3,029	10.4	3.05	130 / 45
				3Φ, 460V, 60Hz	ABG042WA 60Hz	41,500	12,154	3,952	10.5	3.08	130 / 45
					ABG042WA 50Hz	34,400	10,075	3,308	10.4	3.05	130 / 45
				3Φ, 460V, 60Hz	ABG049WA 60Hz	49,700	14,556	4,602	10.8	3.16	130 / 45
					ABG049WA 50Hz	40,400	11,832	3,885	10.4	3.05	130 / 45
				3Φ, 460V, 60Hz	ABG051WA 60Hz	51,000	14,937	4,722	10.8	3.16	130 / 45
					ABG051WA 50Hz	41,700	12,213	4,010	10.4	3.05	130 / 45

Note : COND 130°F(54.4°C), EVA 45°F(7.2°C) / COND 100°F(37.8°C), EVA 50°F(10°C)

Cooling capacity		Input	EER	COP	Test condition (Cond / Eva Temp)	Dimension (mm)		
Btu/hr	Watts	Watts	Btu/W-hr	W/W	°F	A	B	C
39,000	11,422	1,806	21.6	6.33	100 / 50	385	362	263
41,700	12,213	1,931	21.6	6.33	100 / 50	385	362	263
51,600	15,112	2,367	21.8	6.38	100 / 50	419	394	295
57,100	16,723	2,619	21.8	6.38	100 / 50	419	394	295
67,400	19,740	3,092	21.8	6.38	100 / 50	419	394	295
69,500	20,355	3,188	21.8	6.38	100 / 50	419	394	295
39,100	11,451	1,802	21.7	6.36	100 / 50	385	362	263
32,000	9,372	1,488	21.5	6.30	100 / 50	385	362	263
41,600	12,184	1,917	21.7	6.36	100 / 50	385	362	263
34,400	10,075	1,585	21.7	6.36	100 / 50	385	362	263
51,600	15,112	2,367	21.8	6.38	100 / 50	419	394	295
42,400	12,418	1,945	21.8	6.38	100 / 50	419	394	295
57,100	16,723	2,619	21.8	6.38	100 / 50	419	394	295
47,600	13,941	2,183	21.8	6.38	100 / 50	419	394	295
67,500	19,769	3,096	21.8	6.38	100 / 50	419	394	295
55,800	16,342	2,560	21.8	6.38	100 / 50	419	394	295
69,500	20,355	3,188	21.8	6.38	100 / 50	419	394	295
57,700	16,899	2,647	21.8	6.38	100 / 50	419	394	295

- APG

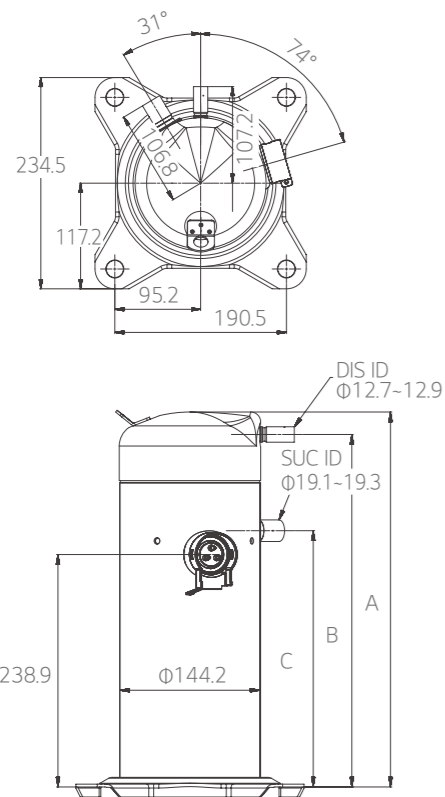

- ABG

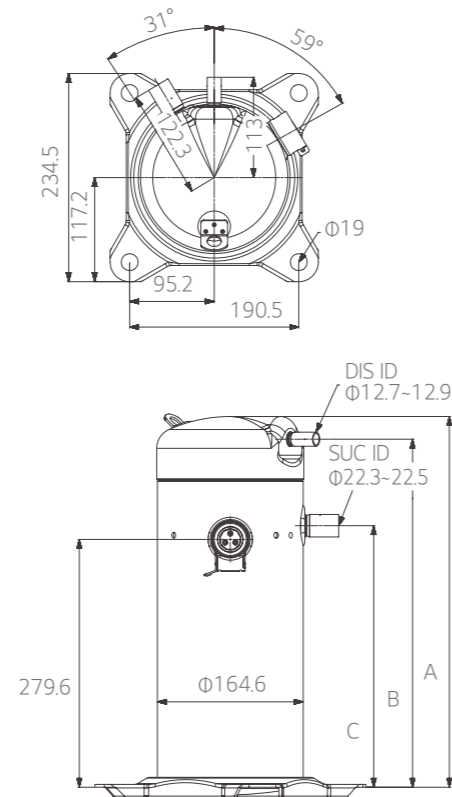

Specification

2 Stage Modulating R410A

Refrigerant	Type	Frequency	Voltage	Series	Model	Power mode (Full load)						
						Cooling capacity		Input	EER	COP	Test condition (Cond / Eva Temp)	
						Btu/hr	Watts	Watts	Btu/W-hr	W/W	°F	
R410A	LSS	60Hz	1Φ, 208-230V	APM	APM020KA	25,000	7,322	1,656	15.1	4.42	115 / 50	
					APM030KA	37,900	11,100	2,399	15.8	4.63	115 / 50	
				ABM	ABM040KA	50,900	14,907	3,222	15.8	4.63	115 / 50	
					ABM051KA	64,100	18,773	4,006	16.0	4.69	115 / 50	
				3Φ, 208-230V	APM	APM030RA	38,000	12,667	2,460	15.4	4.54	115 / 50
					ABM	ABM040RA	50,600	16,867	3,123	16.2	4.77	115 / 50
			3Φ, 575V	APM	APM030TA	38,000	12,667	2,460	15.4	4.54	115 / 50	
					ABM040TA	50,700	16,900	3,169	16.0	4.71	115 / 50	
					ABM051TA	63,000	21,000	3,938	16.0	4.71	115 / 50	
			3Φ, 460V	APM	APM030WA	38,000	12,667	2,460	15.4	4.54	115 / 50	
					ABM040WA	50,500	16,833	3,156	16.0	4.71	115 / 50	
					ABM051WA	63,000	21,000	3,889	16.2	4.76	115 / 50	
50Hz	3Φ, 380-420V	ABM	ABM030WA	30,900	10,300	2,060	15.0	4.41	115 / 50			
			ABM040WA	41,000	13,667	2,611	15.7	4.62	115 / 50			
			ABM051WA	51,500	17,167	3,179	16.2	4.76	115 / 50			

Note: CON 115°F(46.1°C), EVA 50°F(10°C) / COND 100°F(37.8°C), EVA 50°F(10°C)

Saving mode (Part load)						Modulation ratio	Dimension (mm)			Solenoid valve	
Cooling capacity		Input	EER	COP	Test condition (Cond / Eva Temp)		Power / Saving	A	B	C	Voltage
Btu/hr	Watts	Watts	Btu/W-hr	W/W	°F						
19,600	5,740	1,010	19.4	5.68	100 / 50	71.3%	391	368	263	24Vac, 50 / 60Hz	
28,100	8,230	1,419	19.8	5.80	100 / 50	67.7%	391	368	263	24Vac, 50 / 60Hz	
38,600	11,305	1,901	20.3	5.95	100 / 50	68.7%	425	400	295	24Vac, 50 / 60Hz	
48,100	14,087	2,369	20.3	5.95	100 / 50	68.5%	425	400	295	24Vac, 50 / 60Hz	
28,100	9,367	1,435	19.6	5.76	100 / 50	67.7%	391	368	263	24Vac, 50 / 60Hz	
38,300	12,767	1,887	20.3	5.97	100 / 50	68.7%	425	400	295	24Vac, 50 / 60Hz	
48,300	16,100	2,345	20.6	6.06	100 / 50	68.5%	425	400	295	24Vac, 50 / 60Hz	
28,100	9,367	1,415	19.9	5.84	100 / 50	67.7%	391	368	263	24Vac, 50 / 60Hz	
38,600	12,867	1,892	20.4	6.00	100 / 50	68.7%	425	400	295	24Vac, 50 / 60Hz	
48,100	16,033	2,324	20.7	6.09	100 / 50	68.5%	425	400	295	24Vac, 50 / 60Hz	
28,100	9,367	1,435	19.6	5.76	100 / 50	67.7%	391	368	263	24Vac, 50 / 60Hz	
38,600	12,867	1,901	20.3	5.97	100 / 50	68.7%	425	400	295	24Vac, 50 / 60Hz	
48,300	16,100	2,379	20.3	5.97	100 / 50	68.5%	425	400	295	24Vac, 50 / 60Hz	
22,100	7,367	1,175	18.8	5.53	100 / 50	67.7%	391	368	263	24Vac, 50 / 60Hz	
31,400	10,467	1,554	20.2	5.94	100 / 50	68.7%	425	400	295	24Vac, 50 / 60Hz	
38,700	12,900	1,852	20.9	6.15	100 / 50	68.5%	425	400	295	24Vac, 50 / 60Hz	

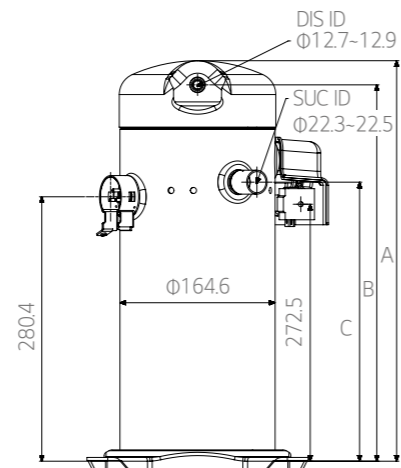
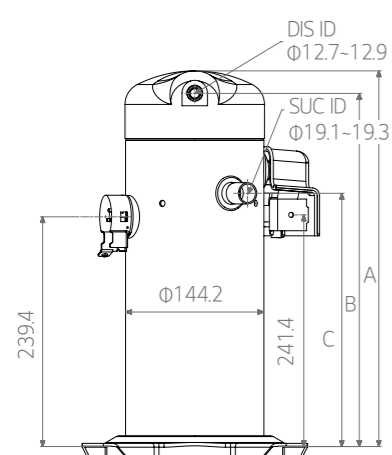
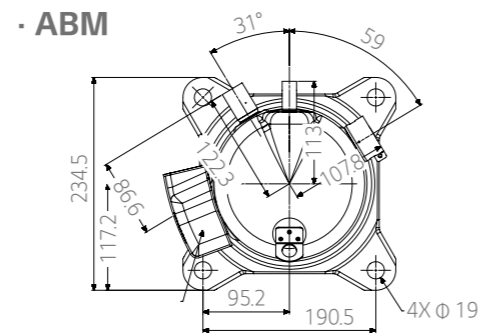
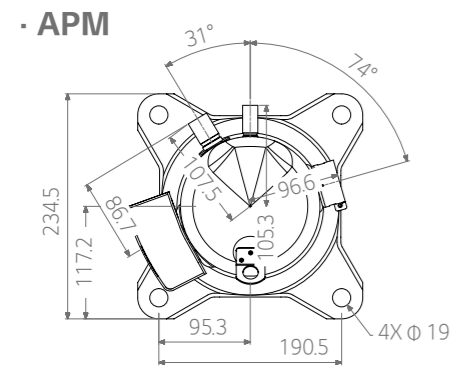

Specification

Variable Speed R410A / R32

Refrigerant	Type	Series	Model	Power	Cooling capacity		Input	EER	COP	Test condition	
					Btu/hr	Watts					
R410A	LSS	APA	APA020DA	DC380V	20,300	5,945	2,010	10.1	2.96	130 / 45	
			APA020MA	DC380V	20,300	5,945	2,030	10.0	2.93	130 / 45	
			APA026DA	DC380V	25,000	7,322	2,475	10.1	2.96	130 / 45	
			APA026MA	DC380V	25,000	7,322	2,475	10.1	2.96	130 / 45	
			APA029MB	DC380V	27,300	7,995	2,625	10.4	3.05	130 / 45	
			ABA042DB	DC380V	44,200	12,945	4,055	10.9	3.19	130 / 45	
		ABA	ABA042MA	DC380V	44,200	12,945	4,131	10.7	3.13	130 / 45	
			ABA051DA	DC380V	53,500	15,669	4,864	11.0	3.22	130 / 45	
			ABA051MA	DC380V	53,500	15,669	4,908	10.9	3.19	130 / 45	
			JQC048MA	DC540V	51,000	14,947	3,300	11.2	4.53	130 / 45	
		HSS	JQC	JQC048MB	DC310V	50,000	14,654	4,620	10.8	3.17	130 / 45
				JQC068MA	DC540V	71,000	20,808	6,200	11.5	3.36	130 / 45
				JQC068MB	DC310V	71,000	20,808	6,300	11.3	3.30	130 / 45
				JBA096MA	DC540V	102,700	30,100	8,800	11.7	3.42	130 / 45
R-Scroll	RJ	RJA036MA	DC520V	37,100	10,873	3,198	11.6	3.40	130 / 45		
		RJB036MB	DC380V	37,100	10,873	3,198	11.6	3.40	130 / 45		
R32	R-Scroll	RJ	RJB036MAA	DC520V	37,700	11,049	3,397	11.1	3.25	130 / 45	
			RJB036MAB	DC520V	37,650	11,034	3,356	11.2	3.29	130 / 45	

Note: COND 130°F(54.4°C), EVA 45°F(7.2°C), COND 100°F(37.8°C), EVA 45°F(7.2°C)

Cooling capacity	Input	EER	COP	Test condition	Range	Dimension (mm)			
						Btu/hr	Watts	Watts	
24,700	7,234	1,280	19.3	5.65	100 / 45	20-70	407	379	250
24,700	7,234	1,293	19.1	5.59	100 / 45	20-70	407	379	250
31,000	9,079	1,566	19.8	5.80	100 / 45	20-70	407	379	250
31,000	9,079	1,598	19.4	5.68	100 / 45	20-70	407	379	250
33,500	9,811	1,642	20.4	5.98	100 / 45	15-100	377	349	220
53,500	15,669	2,716	19.7	5.77	100 / 45	20-70	449	416	297
53,500	15,669	2,758	19.4	5.68	100 / 45	20-70	449	416	297
64,500	18,890	3,241	19.9	5.83	100 / 45	20-70	449	416	297
64,500	18,890	3,274	19.7	5.77	100 / 45	20-70	449	416	297
61,000	17,877	2,905	21.0	6.15	100 / 45	12-165	426	337	489
61,500	18,024	2,943	20.9	6.12	100 / 45	12-165	426	337	489
85,000	24,911	4,060	20.9	6.14	100 / 45	12-165	426	337	489
85,000	24,911	4,130	20.6	6.03	100 / 45	12-165	426	337	489
121,500	35,608	5,690	21.4	6.26	100 / 45	12-160	458	379	527
37,000	10,843	1,697	21.8	6.39	100 / 45	10-150	366	356	332
37,000	10,843	1,697	21.8	6.39	100 / 45	10-150	366	356	332
36,600	10,726	1,803	20.3	5.95	100 / 45	10-150	366	356	332
36,350	10,653	1,766	20.4	6.03	100 / 45	10-150	366	356	332

- APA

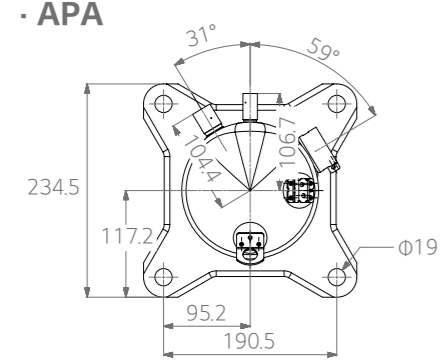

- ABA

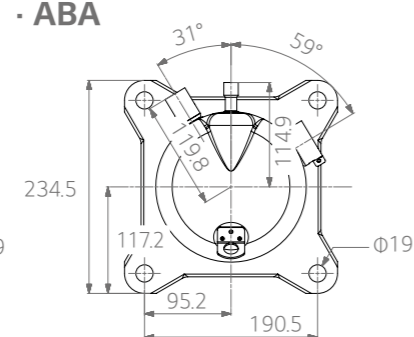

- JQC

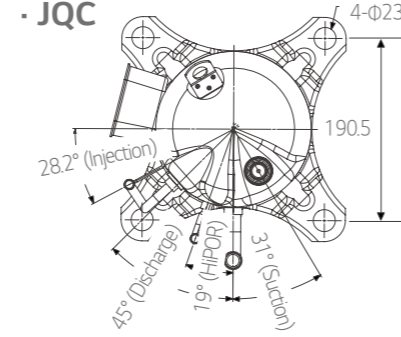

- JBA

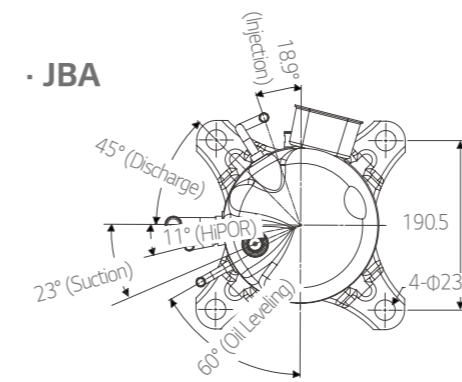

- RJ

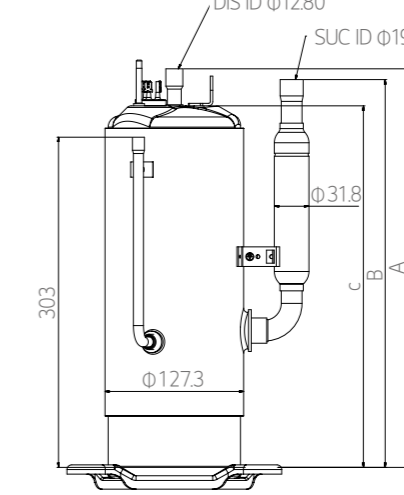
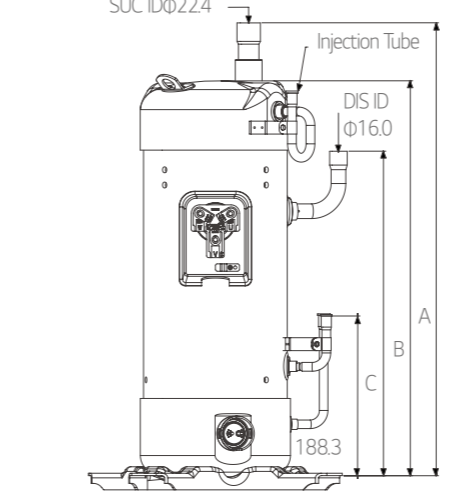
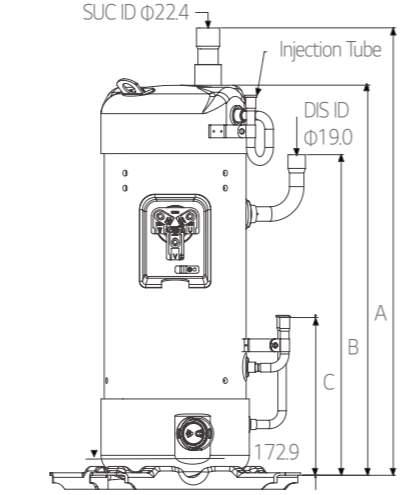
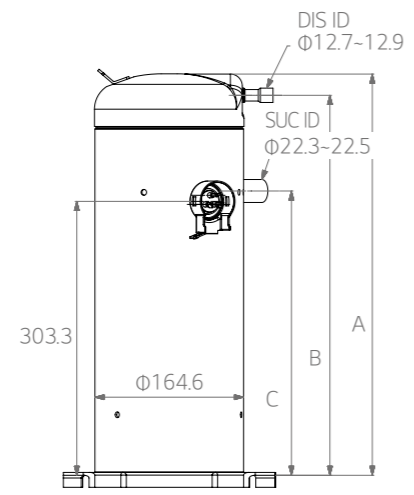
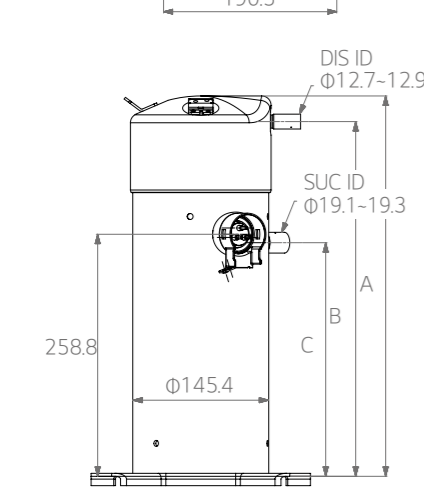
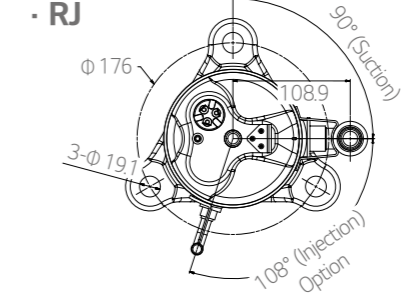

Specification

Special Application for Refrigeration

Refrigerant	Type	Frequency	Voltage	Series	Model	Cooling capacity		Input	EER	COP	Test condition (Cond / Eva Temp)	
						Btu/hr	Watts	Watts	Btu/W-hr	W/W	°F	
R404A	LSS	60Hz	1Φ, 208-230V	MPA	MPA010KA	15,300	4,481	1,779	8.6	2.52	130 / 45	
					MPA013KA	19,800	5,799	2,176	9.1	2.66	130 / 45	
					MPA015KA	23,400	6,853	2,543	9.2	2.69	130 / 45	
					MPA019KA	26,100	7,644	2,868	9.1	2.67	130 / 45	
				MBA	MBA021KA	34,400	10,075	3,909	8.8	2.58	130 / 45	
					MBA026KA	38,500	11,276	4,278	9.0	2.64	130 / 45	
					MBA029KA	43,000	12,594	4,725	9.1	2.67	130 / 45	
					MBA033KA	48,100	14,087	5,286	9.1	2.67	130 / 45	
					MRA	MRA038KA	54,000	15,815	6,585	8.2	2.40	130 / 45
					3Φ, 208-230V	MPA	MPA010RA	15,400	4,510	1,770	8.7	2.55
			MPA013RA	19,600			5,740	2,227	8.8	2.58	130 / 45	
			MPA015RA	23,000			6,736	2,566	9.0	2.63	130 / 45	
			MPA019RA	25,800			7,556	2,867	9.0	2.64	130 / 45	
			MBA	MBA021RA		34,500	10,104	3,833	9.0	2.64	130 / 45	
				MBA026RA		38,100	11,159	4,187	9.1	2.67	130 / 45	
				MBA029RA		43,000	12,594	4,674	9.2	2.69	130 / 45	
				MBA033RA		48,100	14,087	5,344	9.0	2.64	130 / 45	
				MRA		MRA038RA	54,500	15,962	6,337	8.6	2.52	130 / 45
				MRA045RA		65,000	19,037	7,558	8.6	2.52	130 / 45	

Note : COND 130°F (54.4°C), EVA 45°F (7.2°C) / COND 120°F (48.9°C), EVA 20°F (-6.7°C)

Cooling capacity		Input	EER	COP	Test condition (Cond / Eva Temp)	Dimension (mm)		
Btu/hr	Watts	Watts	Btu/W-hr	W/W	°F	A	B	C
9,700	2,841	1,540	6.3	1.85	120 / 20	387	359	230
12,500	3,661	1,894	6.6	1.93	120 / 20	387	359	230
15,200	4,452	2,171	7.0	2.05	120 / 20	387	359	230
16,900	4,950	2,449	6.9	2.02	120 / 20	387	359	230
22,400	6,560	3,294	6.8	1.99	120 / 20	418	385	266
25,000	7,322	3,623	6.9	2.02	120 / 20	418	385	266
27,700	8,113	4,014	6.9	2.02	120 / 20	418	385	266
31,100	9,108	4,574	6.8	1.99	120 / 20	418	385	266
37,000	10,836	5,522	6.7	1.96	120 / 20	455	422	304
9,600	2,812	1,548	6.2	1.82	120 / 20	387	359	230
12,700	3,720	1,954	6.50	1.90	120 / 20	387	359	230
14,900	4,364	2,191	6.8	1.99	120 / 20	387	359	230
16,800	4,920	2,507	6.7	1.96	120 / 20	387	359	230
22,400	6,560	3,294	6.8	1.99	120 / 20	418	385	266
24,800	7,263	3,594	6.9	2.02	120 / 20	418	385	266
27,800	8,142	3,971	7.0	2.05	120 / 20	418	385	266
31,300	9,167	4,536	6.9	2.02	120 / 20	418	385	266
37,200	10,895	5,314	7.0	2.05	120 / 20	455	422	304
45,100	13,209	6,264	7.2	2.11	120 / 20	455	422	304

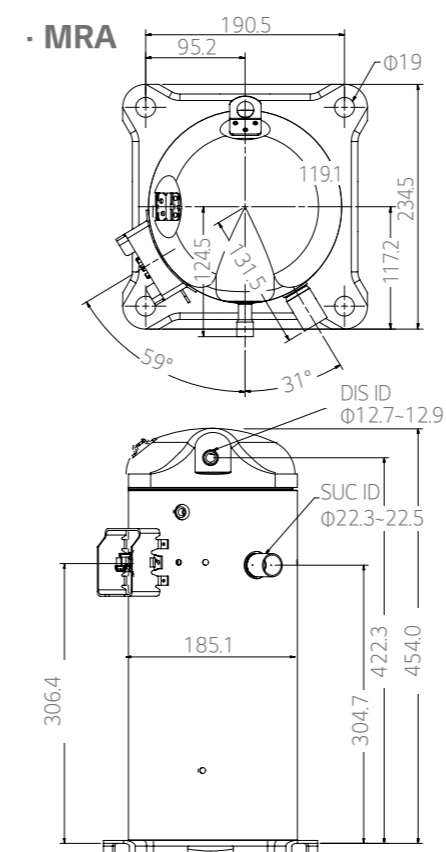
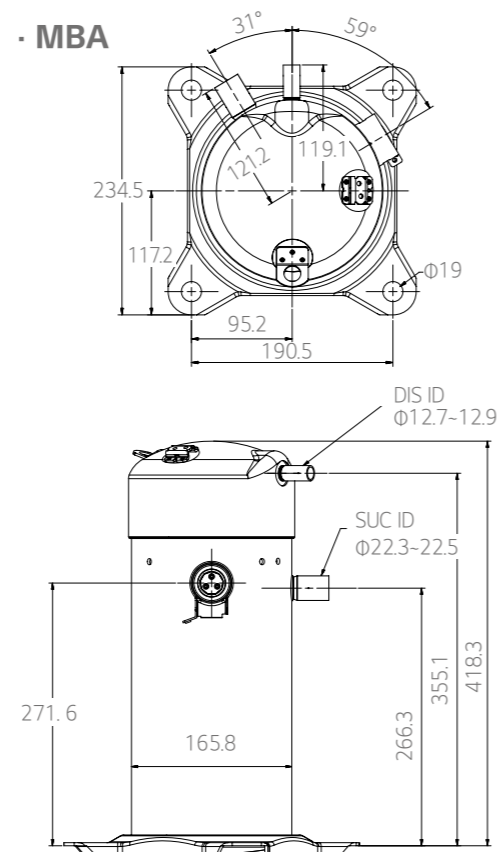
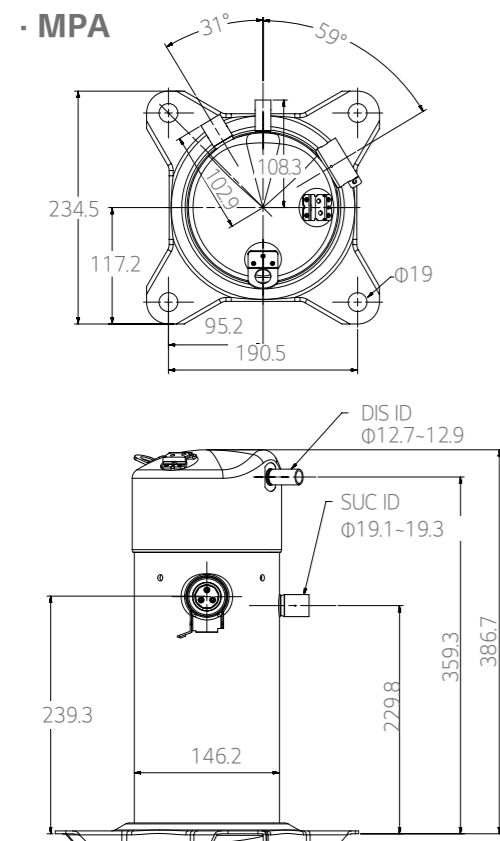

Specification

Special Application for Refrigeration

Refrigerant	Type	Frequency	Voltage	Series	Model	Cooling capacity		Input	EER	COP	Test condition (Cond / Eva Temp)	
						Btu/hr	Watts	Watts	Btu/W-hr	W/W	°F	
R404A	LSS	60Hz	3Φ, 380V	MPA	MPA015UA	22,600	6,619	2,511	9.0	2.64	130 / 45	
					MBA021UA	34,500	10,104	3,833	9.0	2.64	130 / 45	
				MBA	MBA029UA	43,000	12,594	4,674	9.2	2.69	130 / 45	
					MBA033UA	48,400	14,175	5,261	9.2	2.69	130 / 45	
				3Φ, 460V	MPA	MPA010SA	15,500	4,540	1,761	8.8	2.58	130 / 45
						MPA013SA	19,600	5,740	2,202	8.9	2.61	130 / 45
			MPA015SA			22,800	6,678	2,533	9.0	2.64	130 / 45	
			MPA019SA			25,600	7,498	2,844	9.0	2.64	130 / 45	
			MBA		MBA021SA	34,600	10,133	3,844	9.0	2.64	130 / 45	
					MBA026SA	38,000	11,129	4,176	9.1	2.67	130 / 45	
					MBA029SA	42,800	12,535	4,652	9.2	2.69	130 / 45	
					MBA033SA	48,100	14,087	5,286	9.1	2.67	130 / 45	
			MRA	MRA038SA	54,700	16,020	6,360	8.6	2.52	130 / 45		
				MRA045SA	65,000	19,037	7,558	8.6	2.52	130 / 45		

Note : COND 130°F (54.4°C), EVA 45°F (7.2°C) / COND 120°F (48.9°C), EVA 20°F (-6.7°C)

Cooling capacity		Input	EER	COP	Test condition (Cond / Eva Temp)	Dimension (mm)		
Btu/hr	Watts	Watts	Btu/W-hr	W/W	°F	A	B	C
14,750	4,320	2,169	6.8	1.99	120 / 20	387	359	230
22,300	6,531	3,279	6.8	1.99	120 / 20	418	385	266
27,800	8,142	3,971	7.0	2.05	120 / 20	418	385	266
31,500	9,226	4,437	7.1	2.08	120 / 20	418	385	266
9,650	2,826	1,556	6.2	1.82	120 / 20	387	359	230
12,700	3,720	1,924	6.6	1.93	120 / 20	387	359	230
14,900	4,364	2,191	6.8	1.99	120 / 20	387	359	230
16,800	4,920	2,471	6.8	1.99	120 / 20	387	359	230
22,400	6,560	3,294	6.8	1.99	120 / 20	418	385	266
24,800	7,263	3,594	6.9	2.02	120 / 20	418	385	266
27,700	8,113	4,014	6.9	2.02	120 / 20	418	385	266
31,300	9,167	4,536	6.9	2.02	120 / 20	418	385	266
37,800	11,071	5,324	7.1	2.08	120 / 20	455	422	304
45,200	13,238	6,278	7.2	2.11	120 / 20	455	422	304

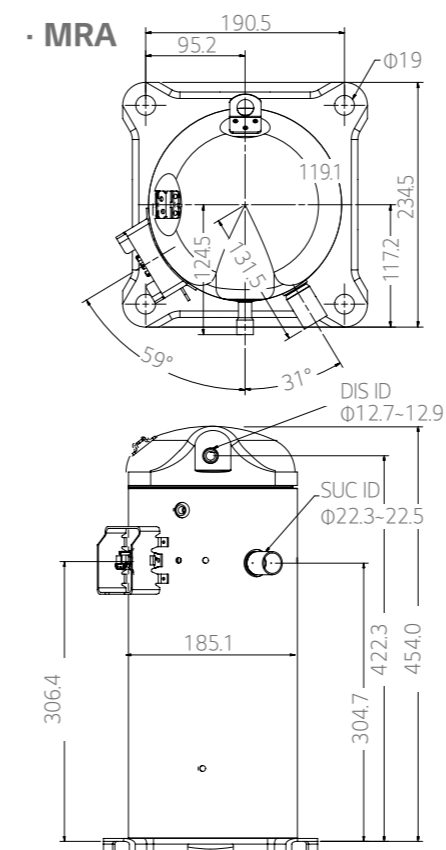
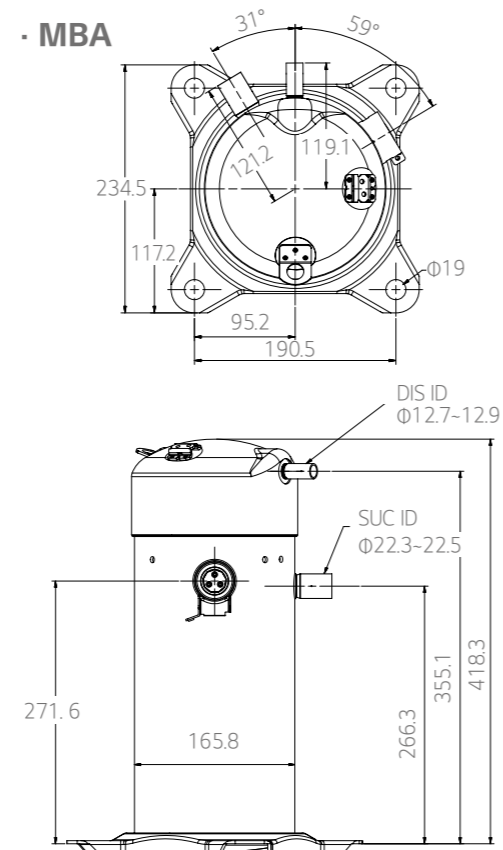
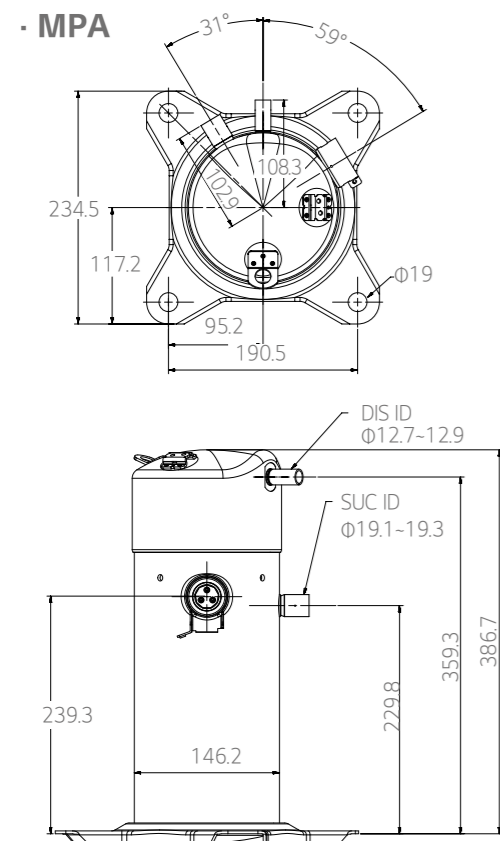

Specification

Special Application for Air to Water Heat Pump

Refrigerant	Type	Frequency	Voltage	Series	Model	Heating capacity		Input Watts	EER Btu/W-hr	COP W/W	Test condition (Cond / Eva Temp) °F
						Btu/hr	Watts				
R410A	R-Scroll	10-150Hz	DC520V	RJ	RJB036MAC	35,000	10,258	3,125	11.2	3.28	130 / 45
R22	LSS	50Hz	1Φ, 220-240V	HSBA	HSBA052PA	56,910	16,668	4,094	13.90	4.07	130 / 45
R410A	LSS	50Hz	1Φ, 220-240V	HABT	HABT057PA	63,100	18,480	4,725	13.35	3.91	130 / 45

Note : COND 130°F (54.4°C), EVA 45°F (7.2°C) / COND 120°F (48.9°C), EVA 20°F (-6.7°C)

Heating capacity		Input Watts	EER Btu/W-hr	COP W/W	Test condition °F	Dimension (mm)		
Btu/hr	Watts					A	B	C
21,200	6,213	2,718	7.8	2.29	120 / 28	366	356	332
53,090	15,549	4,115	12.90	3.78	131 / 41	444	421	315
58,650	17,177	4,770	12.30	3.60	131 / 41	444	421	315

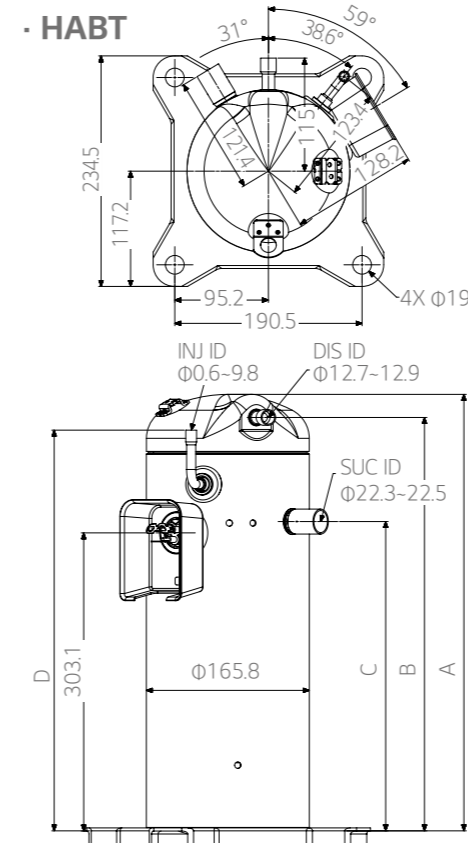
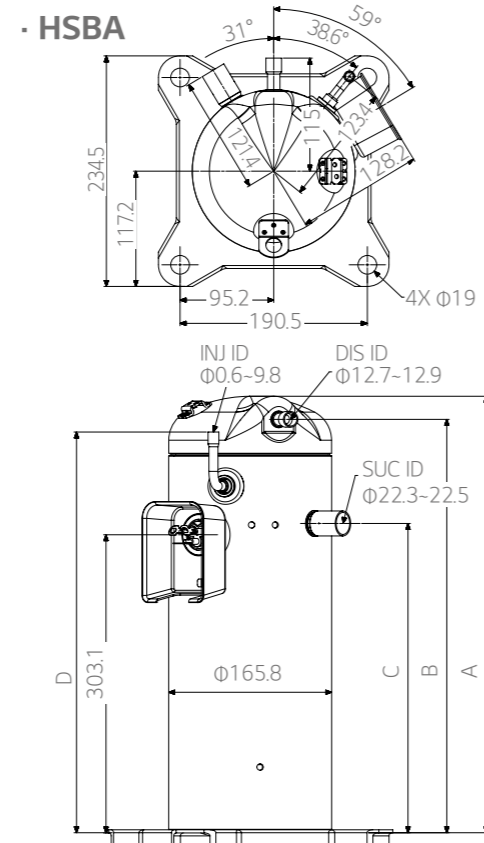
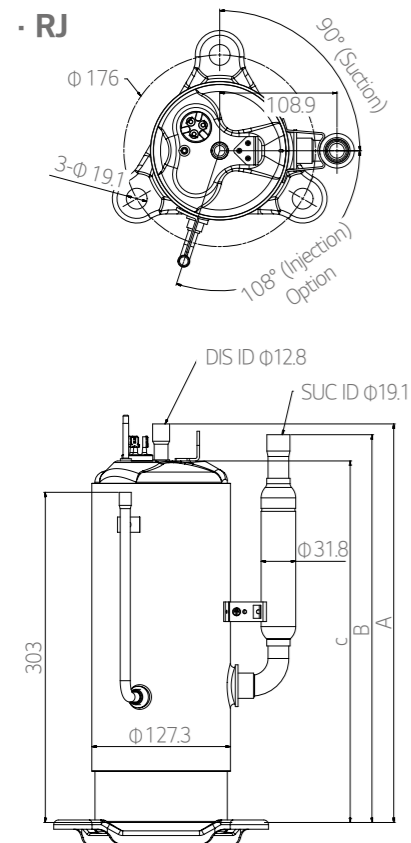

Specification

Drive

Contents	Spec	4kW (1 Phase)	7kW (3 Phase, 230V)	7kW (3 Phase, 460V)
Drive	1 Model name (P/No.)	PDR040K310	PDR070S010	PDR070R010
	2 Rated input voltage	1Φ, 208-230Vac, 50/60Hz	3Φ, 230Vac, 50/60Hz	3Φ, 460Vac, 50/60Hz
	3 Maximum input current	18Arms	11Arms	7Arms
	4 Maximum input power	4,000 W	7,000 W	7,000 W
	5 Operating compressor Hz	20 ~ 70Hz	20 ~ 70Hz	20 ~ 70Hz
	6 Converter type / boost up voltage	I-PFC / 340-400Vdc	B/diode 325Vdc	B/diode 650Vdc
	7 PFC ON / OFF control	Based on Input power 750 / 650 W *1	-	-
	8 Compressor connection color	Red (U) / Blue (V) / Yellow (W)	Red (U) / Blue (V) / Yellow (W)	Red (U) / Blue (V) / Yellow (W)
	9 Ambient operating temperature	-20°C ~ 48°C	-20°C ~ 48°C	-20°C ~ 48°C
	10 Storage temperature	-40°C ~ 60°C	-40°C ~ 60°C	-40°C ~ 60°C
	11 Max. storage relative humidity	85%	85%	85%
Reactor	1 Model name (P/No.)	PDR040K350	PDR070S020	PDR070R020
	2 Rated input voltage	1Φ, 208-230Vac, 50/60Hz	3Φ, 230Vac, 50/60Hz	3Φ, 460Vac, 50/60Hz
	3 Maximum input current	18Arms	25Arms	14Arms
	4 Inductance at 20KHz, 1VAC (20°C)	220μH ± 15%	2mH	13mH
Transformer	1 Model name (P/No.)	-	PDR070S030	PDR070R030
	2 Transformer ratio	-	1 : 1	2 : 1
Noise filter	1 Model name (P/No.)	-	PDR070S040	PDR070S040
	2 Rated input voltage	-	3Φ, 230Vac, 50/60Hz	3Φ, 460Vac, 50/60Hz
	3 Maximum input current	-	25Arms	25Arms

- 4kW

- 3ph 7kW

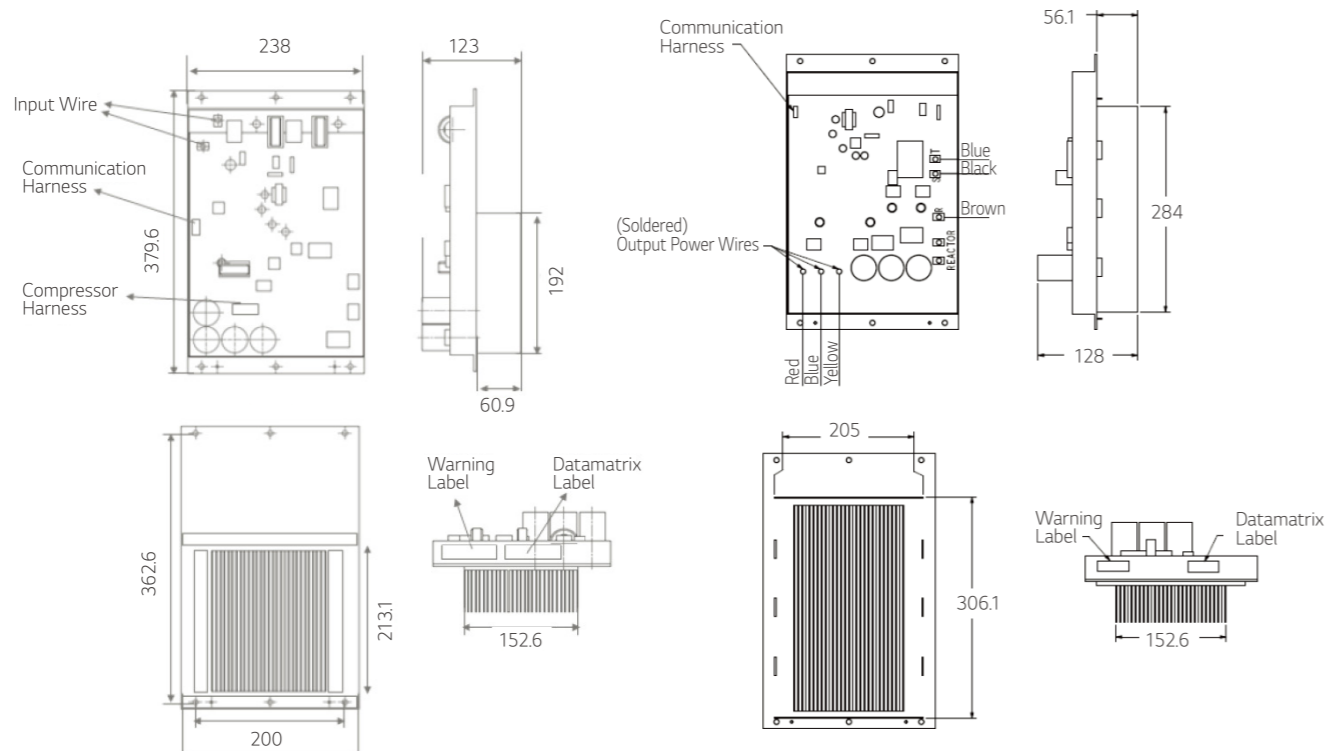

Wiring Diagram

1HP

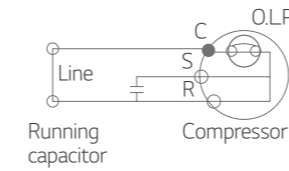

Cover Terminal Fitting

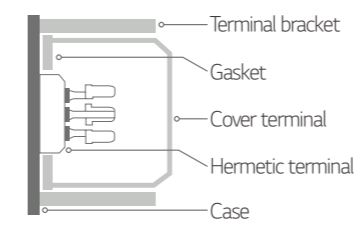

*O.L.P : Over Load Protector

3HP

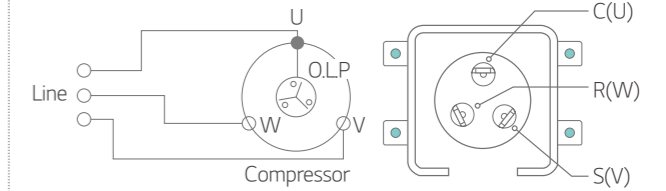

*C.S.R mark is embossed on a Cover terminal.

Mounting

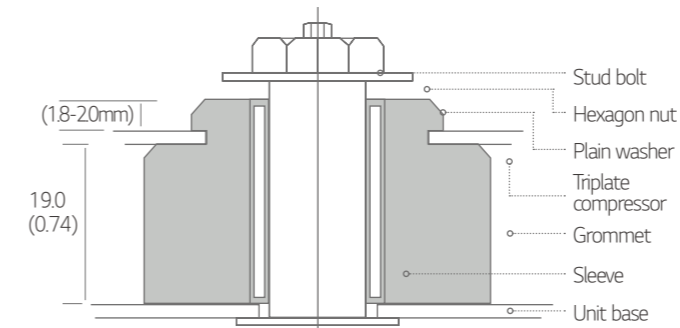

Accessory Parts



Note : 4kW Drive has on board noise filter

Packing & Container Stuffing Quantity

Items	1 Step pallet		2 Steps pallet		1 Container (20ft)				
	Packing quantity	Size	Packing quantity	Size	Packing quantity	Pallet quantity			Total
		B		B		Step 1	Step 2	Accessory	
APA / APB / APG	12	560	24	980 ↓	576	0	24	0	24
	16	560	32	980 ↓	640	0	20	0	20
AQA / AQ	12	560	24	980 ↑	552	0	24	0	24
	16	560	32	980 ↓	544	0	18	0	18
ABA / ABG	12	560	24	980 ↓	432	0	18	0	18
	16	560	32	980 ↓	448	0	14	0	18
SB	12	560	24	980 ↓	432	0	18	0	18
SQ / HQ	12	560	24	980 ↓	552	0	24	1	25
AR / SR	12	-	24	985 ↓	408	14	10	1	25
JB / JQ	9	-	18	985 ↓	315	35	-	1	36
AR / SR	12	-	24	985 ↑	408	14	10	1	25
JB / JQ	9	-	18	985 ↑	315	35	-	1	36

Note1 : Only available 1 Step pallet for HSS.

Note 2 : Packing conditions are subjects to change without notice.

Packing quantity 12, 9

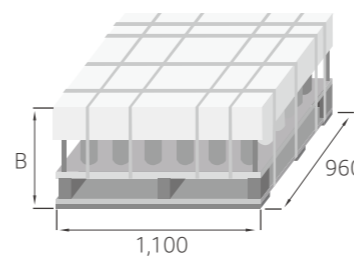

Packing quantity 16

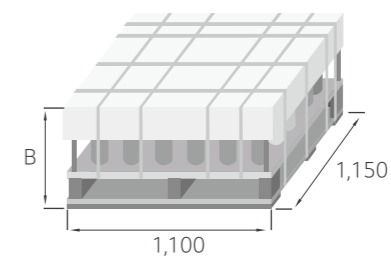

Unit : mm