

19" CLASS (18.5" DIAGONAL)

19LF10C

LCD TV

## LCD Widescreen Integrated HDTV



PUBLIC DISPLAY SETTINGS - CLONING CAPABLE  
Start Up to a certain channel/volume level  
Set min/max volume  
Lock out control panel/remote  
Set Aspect Ratio

 EcoSmart™  
Backlight Control

 ENERGY STAR® 3.0 AND RoHS COMPLIANT

DYNAMIC CONTRAST RATIO  
6,000:1

NATIVE DISPLAY RESOLUTION  
1440 x 900

BUILT-IN ATSC/NTSC/QAM CLEAR TUNER

INVISIBLE SPEAKER SYSTEM  
Hidden speaker grilles

LG'S EXCLUSIVE XD ENGINE®

REAL CINEMA™

HDMI™ INPUT WITH HDCP  
V.1.3

2 YEAR LIMITED WARRANTY  
(parts and labor)

[www.LGcommercial.com](http://www.LGcommercial.com)

 **LG**  
Life's Good

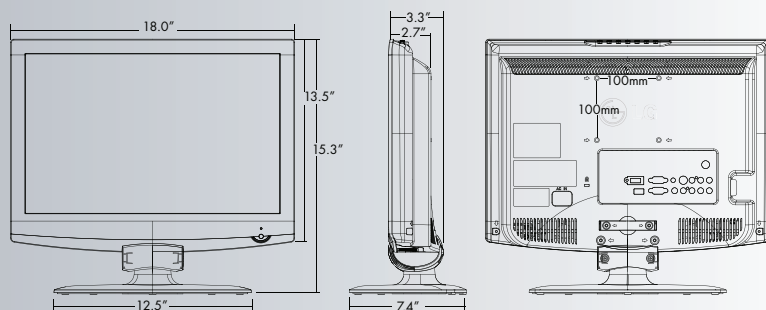

Rear Jack Panel

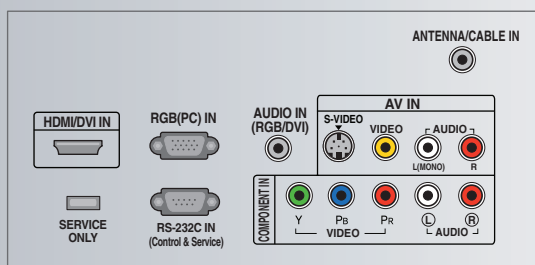
**LCD SPECIFICATION**

Screen Size (Class)	19" class (18.5" diagonal)
Native Display Resolution	1440 x 900
Brightness	300 cd/m <sup>2</sup>
Dynamic Contrast Ratio	6,000:1
Contrast Ratio	1,000:1
Viewing Angle	170°/160°
Color Reproduction	8 Bit
Response Time	5ms
Life Span (Typical)	60,000 hrs

**BROADCASTING SYSTEM**

Analog	Yes
ATSC/NTSC/Clear QAM	Yes

**VIDEO**

XD Engine	Yes
Aspect Ratio	16:10
Aspect Ratio Correction	6 Modes
Just Scan (0% overscan)	
HDMI	1080p/1080i/720p
Component	1080p/1080i/720p
RF/DTV	1080p/720p
Enhanced Noise Reduction (Video Noise Filter)	Yes (3D NR/MPEG NR)
Color Temperature Control	3 Modes (Warm, Med, Cool)
Black Stretcher	Yes
24p Real Cinema (24p 5:5/2:2 pull down) -HDMI	Yes
AV Mode II (Picture & Sound)	3 Modes (Cinema, Sport, Game)
EZ Picture/PSM	Yes, 7 Modes
Fresh White	Yes

**AUDIO**

Mono/Stereo/Dual (MTS/SAP)	Yes
Audio Output Power (Watts - THD 10%)	3W + 3W
Invisible Speaker System Details	1 Way 2 Speakers
Dolby Digital 5.1 Decoder	Yes
Bass/Treble/Balance Controls	Yes
Sound Mode	5 Modes

**SPECIAL FEATURES**

Public Display Settings	Yes
EcoSmart - Backlight Control	Yes
1080p Source Input	
HDMI	60p/30p/24p
Component	60p/30p/24p
RGB	WXGA
A/V Input Navigation/EZ input Searching	Yes
Quick View (Previous Channel)	Yes
Quick Setup Guide	Yes
Parental Control w/V-Chip	Yes
Key Lock/Child Lock	Yes
Closed Caption/Sub-title	Yes

**CONVENIENCE FEATURES**

Language	English/Spanish/French
Alvin UI	Yes
Auto Tuning/Manual Tuning	Yes
Channel Edit	Yes
Channel Labeling	Yes
Favorite Channel	Yes
Auto/Manual Clock	Yes
On/Off Timer/Sleep Timer	Yes
Auto Off/Auto Sleep (When no video is present)	Yes

**AUDIO/VIDEO INPUTS/OUTPUTS**

RF In (Antenna/Cable)	1
L/R Audio/Composite Video In	1
HD Component Video In (Y, Pb, Pr) + L/R Audio	1
HDMI/HDCP Input	1 (V1.3)
RGB In (D-Sub 15pin) - PC	1 (1280 x 768)
Audio Input	1
RS-232c In (Control/Service)	1
USB Input	1 Service only
Headphone Input	1

**CABINET/ACCESSORIES**

Cabinet Color	Glossy Black
Fire Retardant Cabinet Material	Yes
Kensington Security System Slot	Yes
VESA® Compliant (WxH)	100mm x 100mm, M4 screw
Remote Control	Yes
Cable Management Clip	Yes

**POWER**

Voltage, Hz	100V - 240V, 50/60 Hz
Stand-by Mode	Less than 1W
Power Consumption Max/Typical	48W/45W
ENERGY STAR 3.0 Compliant	Yes
RoHS Compliant	Yes

**DIMENSIONS & WEIGHT**

TV without stand (WxHxD)	18.0" x 13.5" x 2.7" (3.3")
TV with stand (WxHxD)	18.0" x 15.3" x 7.4"
Shipping Dimensions (WxHxD)	20.5" x 16.6" x 6.8"
TV without stand weight	10.8 lbs
TV with stand weight	11.7 lbs
Shipping Weight	14.3 lbs

**SERVICE/LIMITED WARRANTY**

	2 Years (Parts/Labor)
--	-----------------------

**UPC CODE**

19LF10C	7 19192 17649 2
---------	-----------------

www.LGcommercial.com

LG Electronics U.S.A., Inc.  
Business Solutions Division  
2000 Millbrook Drive  
Lincolnshire, IL 60069



Customer Service: 888.865.3026

Contact your LG Regional Sales Representative

Enterprise: 800.897.8788

Channel: 800.897.8871

Hospitality: 800.228.1236

E-mail: LGcommercial@lge.com

SPEC\_19LF10C\_100901\_PR

All screen images are simulated. Dimensions and weights are approximate. Design, features and specifications subject to change without notice.

© Copyright 2009 LG Electronics USA, Inc. All Rights Reserved. "LG Life's Good" is a registered trademark of LG Corp. XD Engine is a registered trademark of LG Electronics USA, Inc. Dolby is a registered trademark of Dolby Laboratories. VESA is a trademark of Video Electronics Standards Association. All other product and brand names are trademarks or registered trademarks of their respective companies.

Printed in the USA. September 2009



**LG**  
Life's Good