



Personal Fitness Smart Touch Screen TV

15LS766F

Provide your clients and members with the smart solutions, 15.6" multi-touch based smart TV, for a superior workout experience. The 15LS766F series enables interactive service with its multi-touch screen and webOS operating system. Its industrial panel is durable and will sustain long operation. The LG IPS panel technology provides great viewing angles for multiple viewers in a fitness environment.

Personal Fitness Smart Touch Screen TV

15LS766F

Interactive Fitness TV Solution

Intuitive Multi-touch Display

This touch screen recognizes the presence of more than two points of contact with the surface, allowing more users in a fitness setting to experience interactive services (e.g., trainer and client) and entertainment.



Perfect Viewing with LG IPS and Instant On

This TV has an LG IPS Panel which delivers awe-inspiring picture quality across the entire screen, even from wide viewing angles. The "Instant On" feature allows immediate TV power-on and picture display with no long boot-up time delay for the client.



Pre-loaded Apps (including gaming apps)

Clients can be served with pre-loaded applications, including many popular games, Youtube, Web Browser and others.

Apps:

- Smartshare
- Screen Share
- Web Browser
- YouTube
- Arirang TV
- Accuweather

Games:

- Parking Panic
- Genius Memory
- Maya Brick Breaker
- Water Blast
- 3 Cats
- Balda
- 4 in a ROW
- 2048

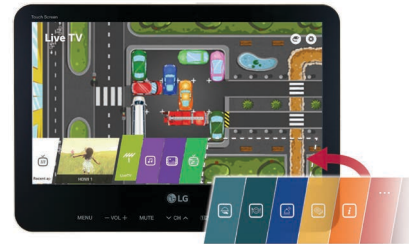

* Actual in-screen image may differ.

UL Certified - Perfect for Public Spaces

The 15LS766F is UL listed to ensure lower operating temperature, lower leakage current and a third wire grounding conductor to provide a product so stringently designed it can even be used in fitness environments.



Personal Fitness Smart Touch Screen TV

15LS766F

Smart Experience

Pro:Centric Information Management Solution

Pro:Centric SMART is optimized for customizing information and entertainment services through an IP & RF infrastructure. With its high picture quality, sophisticated design and advanced connectivity functions, the 15LS766F Series improves and creates new workout experiences for clients, members and staff.

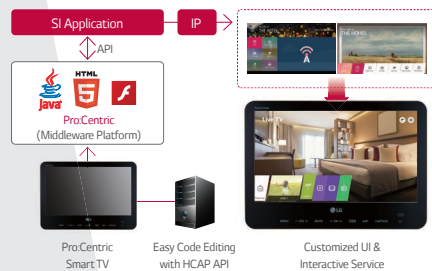

Pro:Centric Direct Solution

Pro:Centric Direct is a content management system that supports simple editing tools and provides various solutions such as 1-click service and IP-network-based remote management. With this solution, clubs are able to customize the user interface while managing the TV content efficiently.

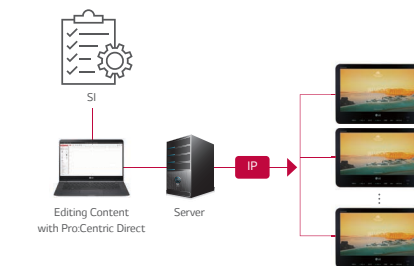

* Actual user interface may look different.

Pro:Idiom

Securely provide entertainment content with Pro:Idiom DRM (Digital Right Management) which prevents illegal copying on your LG devices.



Pro:Idiom

Antimicrobial Properties Applied

Antimicrobial properties applied to the plastic housing of the 15LS766F series conform with the ISO 22196 standard.*

Power Over Coax (PoC)

The 15LS766F can be powered over coax cable which can be routed (along with other cables) through its arm adapter. The arm adapter connects the TV with an optional mounted arm* for ease of viewing in fitness environments where flexible placement is needed to best serve clients and facility needs.



* NOTES:

- Antimicrobial properties : Antimicrobial properties do not protect users against bacteria, viruses, germs or other disease causing microorganisms.
- External plastic housing excludes front LCD panel.
- ISO 22196: Measurement of antimicrobial activity on plastics and other non-porous surfaces.

Dimensions

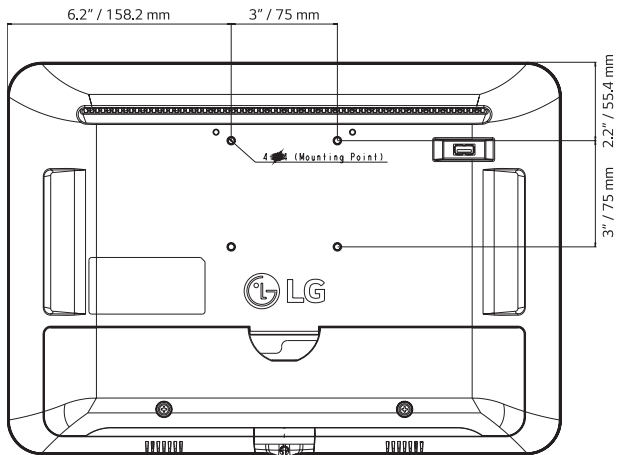
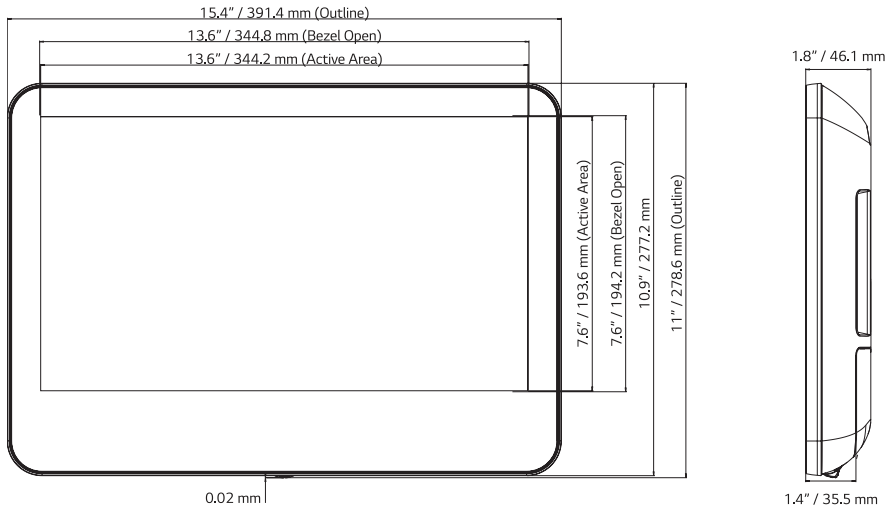

* Dimensions may differ from the above image, so please contact LG sales team to verify before ordering.

Specifications

15LS766F

	Screen Size	15.6"
	Backlight Type	LED (Edge)
	Resolution	1,920 x 1,080 (FHD)
	Brightness nits	250 (Typ) / 220 (Min)
PANEL	Static (Panel) Contrast Ratio	700 (Typ)
	Viewing Angle (L-R, T-B)	160°, 160°
	Response Time (G to G, ms)	25
	Life Span (hrs)	50,000
	Touch Screen	10 Point Multi Touch PCAP, Accuracy < 2mm
	Digital (Terrestrial, Cable, Satellite)	ATSC, Clear QAM
BROADCASTING SYSTEM	Analog	NTSC
	Closed Caption	Yes
	MPEG-2 / MPEG-4 H.264 Decoding	Yes
	IPTV Capable	Yes
	XD Engine	Yes
VIDEO	Aspect Ratio	16:9, Original, 4:3, Just Scan
	Picture Mode	7 modes: Vivid, Standard, APS, Cinema, Sports, Game, Expert (Bright Room), Expert (Dark Room)
AUDIO	Audio Output	2 W + 2 W
	Speaker System	2.0 ch
	Sound Mode	Yes 6 modes: Standard, Cinema, Clear Voice III, Sports, Music, Game
	Clear Voice	Yes
SMART TV SOLUTIONS	Solution Type	ProCentric (Smart, V, Direct)
	Data Streaming (IP & RF)	Yes
	RF	Yes (1 Tuner)
	HCAP (GEM/HTML)	Yes
	* Service Carousel (TLX, Firmware)	Yes
	Multicast/Unicast Ready	Yes
	webRTC	Yes
	DRM	Prodiom (S/W)
SMART FEATURES	webOS 3.5, Commercial Smart Home, Web Browser, Pre-loaded Apps, SDP Server Compatibility, SoftAP, Wi-Fi (bandwidth), Screen Share (Miracast), Smart Share (DLNA), DIAL, Bluetooth Audio Playback, LG Sound Sync / Bluetooth	
DEVICE MANAGEMENT FEATURES	Welcome Screen, Insert Image, Instant On, Full Touch Screen (PCAP), Auto Off / Sleep Timer, Smart Energy Saving, Motion Eye Care, USB Cloning	
JACK INTERFACE	Set Bottom	Headphone Out (replaceable module)
	Set Rear	HDMI/HDCP In, LAN (RJ45), IR IN, USB, MPI, DC In, RF/AC In [PoC (Power over Coax)]
MECHANICAL	VESA	75 x 75 mm
	Color	Front: Black / Back: Black
	Bezel Width	23.5mm (T/L/R) / 59.7mm (B)
	W x H x D (without packing or arm adaptor)	15.4" x 11" x 1.8" / 391.4 x 278.6 x 46.1 mm
	W x H x D (with packing, without arm adaptor)	18" x 7.9" x 14" / 458.0 x 201.0 x 356.0 mm
	Weight (without packing or arm adaptor)	6.4 lbs / 2.9 kg
	Weight (without packing, with arm adaptor)	8.0 lbs / 3.7 kg
	Weight (including packing and arm adaptor)	9.9 lbs / 4.5 kg
	Optional Adapter (AM-PW18BA)	Input: 100V - 240V AC 50/60Hz, Output: 19V DC 3.42A
POWER	Max	35W
	PoC (Power over Coax)	Range 20V - 34V AC or DC
	Standby	Adapter: 0.5W ↓ / PoC: 0.5W ↓
OTHER	Compliance	UL, FCC, RoHS, NOM, NRC, CE, CEC
	Warranty	2 Year

<http://www.lg.com/us/business/commercial-display>
<http://www.twitter.com/LGCommDisplays>
<http://www.facebook.com/LGcommercialdisplays>
<http://www.linkedin.com/company/lg-commercial-displays-usa>
<http://www.youtube.com/lgcommercialdisplayusa>

Copyright 2022 ©LG Electronics USA, Inc., 2000 Millbrook Drive Lincolnshire, IL 60069, USA.
 All rights reserved. LG and the LG logo are registered trademarks of LG Corp. All other products and brand names are trademarks or registered trademarks of their respective companies.
 Designs, features, and specifications are subject to change without notice. All screen images are simulated.
 SPEC_15LS766F_072232_LR

